

LISTEN.
THINK.
SOLVE.®

PowerFlex® 70



TECHNICAL DATA

ADJUSTABLE FREQUENCY AC DRIVES

Product Overview

PowerFlex® 70 drives are designed to worldwide standards providing out-of-the-box performance around the globe. Available ratings include: 0.5 to 25 Hp output at 240V ac input, 0.5 to 50 Hp output at 480V ac input, 0.5 to 50 Hp output at 600V ac input.

The PowerFlex 70 drive can be used with a full featured LCD Human Interface Module, which provides multilingual text for startup, metering, programming and troubleshooting.

The PowerFlex 70 can be programmed for either Volts per Hertz, Sensorless Vector or Vector Control with FORCE™ Technology to cover a wide range of applications from fans to extruders.

Optional internal communication modules provide fast and efficient control and/or data exchange with host controllers over popular interfaces. These interfaces include: DeviceNet™, EtherNet, ControlNet™, Remote I/O, Serial Communications and other open control and communication networks. PC tools such as DriveExplorer™ and DriveTools™ SP assist with programming, monitoring, and troubleshooting the PowerFlex 70.



Table of Contents

<u>Description</u>	<u>Page</u>
Standard Drives Program	3
Catalog Number Explanation	5
Factory Installed Options	7
User Installed Options	8
Installation Considerations	16
Cable Recommendations	22
Single-Phase Input Power	23
Power Ratings and Branch Circuit Protection	23
Maximum Motor Cable Lengths	25
Mounting	29
PowerFlex 70 Frames	29
Approximate Dimensions	30
PowerFlex 70 Configured Drives	35
Standard Drive Specifications	37
Derating Guidelines	42

Reference Materials

For additional PowerFlex 70 data and general drive information, refer to the following publications:

Title	Publication	Available Online at . . .
PowerFlex 70 User Manual	20A-UM001...	www.rockwellautomation.com/literature
PowerFlex Reference Manual	PFLEX-RM001...	
Wiring and Grounding Guidelines for PWM AC Drives	DRIVES-IN001...	
Preventive Maintenance of Industrial Control and Drive System Equipment	DRIVES-TD001...	
Safety Guidelines for the Application, Installation and Maintenance of Solid State Control	SGI-1.1	

For other information, contact Allen-Bradley Drives Technical Support:

Title	Online at . . .
Allen-Bradley Drives Technical Support	www.ab.com/support/abdrives

Standard Drives Program

Flexible Packaging and Mounting

IP20, NEMA/UL Type 1 – For conventional mounting inside or outside a control cabinet. Conduit plate is vertically removable for easy installation and replacement without disturbing conduit.

IP66, NEMA/UL Type 4X/12 (Indoor Use) – For mounting directly in the production environment. Listed by UL to resist dust, dirt, etc. and to survive high pressure water spray. Also certified by NSF International to assure conformity with international food equipment standards.

Flange Type – For mounting heatsink through back of an enclosure, thus removing a large portion of the heat inside a cabinet. The backside is rated IP66, NEMA/UL Type 4X/12 for both indoor and outdoor use.

Zero Stacking™ - Drives can be mounted directly next to one another with no reduction of ambient temperature rating (50° C for IP20, NEMA/UL Type 1 and Flange Mount; 40° C for IP66, NEMA/UL Type 4X/12).

Space Saving Hardware Features

Integral EMC Filtering provides a compact, all-in-one package solution for meeting EMC requirements, including CE in Europe.

Integral Dynamic Brake Transistor delivers a cost-effective means of switching regenerative energy without costly external chopper circuits.

Internal Dynamic Brake Resistor requires no extra panel space, and supplies a large amount of braking torque for short periods.

Easy to Use Human Interface Tools

- PowerFlex 7-Class LCD Human Interface Modules provide:
 - Large and easy to read 7 line x 21 character backlit display
 - Variety of languages (English, French, German, Italian, Spanish, Portuguese, Dutch)
 - Alternate function keys for shortcuts to common tasks
 - “Calculator-like” number pad for fast and easy data entry (Full Numeric version only)
 - Control keys for local start, stop, speed, and direction
 - Remote versions for panel mount applications
- PC-based Configuration tools include:
 - **DriveExplorer™ and DriveExplorer Lite:** A simple and flexible “On-line” tool for monitoring and configuration while connected to a drive.
 - **DriveTools™ SP:** A suite of software tools which provide an intuitive means for programming, troubleshooting and maintaining Allen-Bradley AC and DC drives.
- For simplified AC drive start-up and reduced development time, we’ve integrated Allen-Bradley PowerFlex drive configuration with RSLogix™ 5000 software. This single-software approach simplifies parameter and tag programming while still allowing stand-alone drive software tool use on the factory floor.

Outstanding Control and Performance

Vector Control with FORCE™ Technology ❶ provides outstanding torque and speed regulation, with or without encoder feedback.

Sensorless Vector Control develops high torque over a wide speed range, and adapts to individual motor characteristics.

Drives Features

Fast acting **Current Limit** and **Bus Voltage Regulation** result in maximum acceleration and deceleration without tripping.

Flying Start delivers smooth connection into rotating loads, regardless of commanded direction, without the need for any speed feedback device.

PI Control can eliminate the need for a separate process loop controller.

Inertia Ride-Through offers tripless operation during a prolonged power outage by using the rotating energy stored in high inertia, low friction loads.

User Sets, allowing up to three complete sets of parameter data, can be individually loaded for different batch processes.

Slip compensation delivers minimum of 0.5% open loop speed regulation across a wide speed range, eliminating the need for speed feedback devices in some applications.

Safe Off Option ❶, the first offering available within the DriveGuard™ series of safety solutions, prevents a drive from delivering rotational energy to motors by integrating a safety circuit with the drive’s power switching signals. This solution meets EN 954-1, Category 3.

Droop Control ❶ for load sharing applications.

Sleep/Wake Control ❶ for analog control of start and stop.

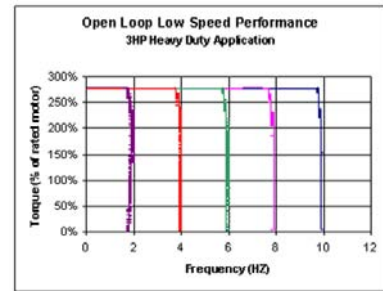
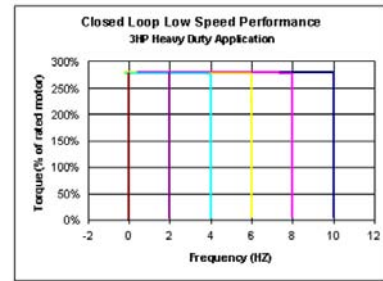

❶ Feature available for Enhanced Control only.

Unsurpassed Capability in Network Communications

PowerFlex drives are fully compatible with the wide variety of Allen-Bradley DPI™ communication adapters, offering the following benefits:

BACnet®	DeviceNet™	ControlNet™	EtherNet/IP	Remote I/O	RS-485 DF1	Profibus DP	Interbus	LonWorks	Modbus RTU	Modbus TCP	Metasys N2	Siemens P1 FLN	Bluetooth®	Description
	✓	✓	✓											Disconnected Messaging permits other network devices (e.g. PanelView) to communicate directly to a drive without routing the communication through the network scanner.
✓	✓	✓	✓		✓				✓				✓	Adapter Routing – Plug PC into one drive and talk to other Allen-Bradley drives on same network, without being routed through the network scanner.
✓	✓	✓	✓	✓	✓	✓	✓	✓	✓	✓	✓	✓	✓	Access to 100% of all parameters over the network.
✓	✓		✓		✓								✓	AutoBaud capability makes initial connections less problematic.
	✓													Change Of State significantly reduces network traffic by configuring control messages to be sent only upon customer defined states. Very flexible configuration for each node (Example: "reference must change by more than 5%").
	✓		✓											Peer Control provides master slave type control between drives, where one or more slave drives (consumers) can run based on the status of a master drive (producer), which can also significantly reduce network traffic.
	✓													Automatic Device Replacement (ADR) saves significant time and effort when replacing a drive, by allowing the scanner to be configured to automatically detect a new drive and download the required parameter settings.
✓	✓	✓	✓	✓	✓	✓	✓	✓	✓	✓	✓	✓	✓	Flexible Fault Configuration – Adapters can be programmed to take fault based actions such as ramp to stop, cost to stop, and hold last state, as well as send user configurable logic control and speed reference values. In addition, different actions can be taken based on whether the network experienced a serious problem (broken cable etc.) versus a network idle condition (PLC set to "Program").

Catalog Number Explanation

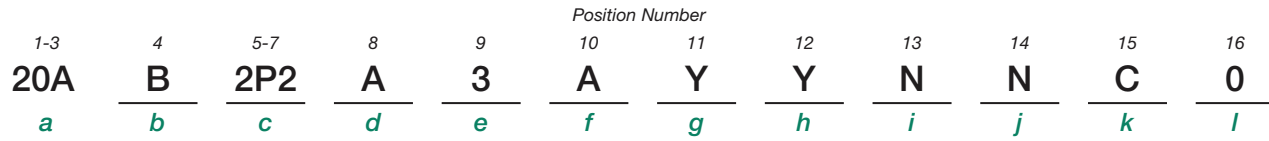

a

Drive	
Code	Type
20A	PowerFlex 70

b

Voltage Rating		
Code	Voltage	Ph.
B	240V ac	3
C	400V ac	3
D	480V ac	3
E	600V ac	3

c1

ND Rating		
208V, 60 Hz Input		
Code	Amps	kW (Hp)
2P2	2.5	0.37 (0.5)
4P2	4.8	0.75 (1.0)
6P8	7.8	1.5 (2.0)
9P6	11	2.2 (3.0)
015	17.5	4.0 (5.0)
022	25.3	5.5 (7.5)
028	32.2	7.5 (10)
042	43	11 (15)
054	62.1	15 (20)
070	78.2	18.5 (25)

c2

ND Rating		
240V, 60 Hz Input		
Code	Amps	kW (Hp)
2P2	2.2	0.37 (0.5)
4P2	4.2	0.75 (1.0)
6P8	6.8	1.5 (2.0)
9P6	9.6	2.2 (3.0)
015	15.3	4.0 (5.0)
022	22	5.5 (7.5)
028	28	7.5 (10)
042	42	11 (15)
054	54	15 (20)
070	70	18.5 (25)

c3

ND Rating		
400V, 50 Hz Input		
Code	Amps	kW (Hp)
1P3	1.3	0.37 (0.5)
2P1	2.1	0.75 (1.0)
3P5	3.5	1.5 (2.0)
5P0	5.0	2.2 (3.0)
8P7	8.7	4.0 (5.0)
011	11.5	5.5 (7.5)
015	15.4	7.5 (10)
022	22	11 (15)
030	30	15 (20)
037	37	18.5 (25)
043	43	22 (30)
060	60	30 (40)
072	72	37 (50)

c4

ND Rating		
480V, 60 Hz Input		
Code	Amps	kW (Hp)
1P1	1.1	0.37 (0.5)
2P1	2.1	0.75 (1.0)
3P4	3.4	1.5 (2.0)
5P0	5.0	2.2 (3.0)
8P0	8.0	3.7 (5.0)
011	11	5.5 (7.5)
014	14	7.5 (10)
022	22	11 (15)
027	27	15 (20)
034	34	18.5 (25)
040	40	22 (30)
052	52	30 (40)
065	65	37 (50)

c5

ND Rating		
600V, 60 Hz Input *		
Code	Amps	kW (Hp)
0P9	0.9	0.37 (0.5)
1P7	1.7	0.75 (1.0)
2P7	2.7	1.5 (2.0)
3P9	3.9	2.2 (3.0)
6P1	6.1	4.0 (5.0)
9P0	9.0	5.5 (7.5)
011	11	7.5 (10)
017	17	11 (15)
022	22	15 (20)
027	27	18.5 (25)
032	32	22 (30)
041	41	30 (40)
052	52	37 (50)

* CE certification testing has not been performed on 600V class drives.

d

Enclosure	
Code	Enclosure
A	Panel Mount - IP 20, NEMA/UL Type 1
C	Wall/Machine Mount = IP66, NEMA/UL Type 4X/12 for indoor use only
F	Flange Mount - Front Chassis = IP 20, NEMA/UL Type 1; Rear Heatsink = IP66, NEMA/UL Type 4X/12 for indoor/outdoor use
G	Wall/Machine Mount - IP54, NEMA/UL Type 12
L	Flange Mount with Conformal Coat
M	Panel Mount with Conformal Coat

e

HIM	
Code	Interface Module
0	Blank Cover
3	Full Numeric LCD
5	Prog. Only LCD
8	Wireless Interface Module - IP66, NEMA/UL Type 4X/12 Only

1-3		4	5-7	8	Position Number				13	14	15	16
20A		B	2P2	A	3	A	Y	Y	N	N	C	0
<i>a</i>		<i>b</i>	<i>c</i>	<i>d</i>	<i>e</i>	<i>f</i>	<i>g</i>	<i>h</i>	<i>i</i>	<i>j</i>	<i>k</i>	<i>l</i>

f

Documentation	
Code	Type
A	English User Manual and Multi-Language Quick Start
N	No Manual
C	Chinese Documentation

g

Brake IGBT	
Code	w/Brake IGBT
Y	Yes

h

Internal Brake Resistor	
Code	w/Resistor
Y	Yes
N	No

i

Emission Class	
Code	Rating
A	Filtered* A* & B Frames (Optional) C, D, & E Frames (Standard)
N	Not Filtered* A & B Frames (Optional) C, D, & E Frames

* 600V Frames A through D available only without filter (Cat. Code N). 600V Frame E available only with filter (Cat. Code A).

‡ Increases size to Frame B.

j

Comm Slot	
Code	Version
B	BACnet
C	ControlNet (Coax)
D	DeviceNet
E	EtherNet/IP
R	RIO
S	RS485 DF1
N	None

k

Control & I/O		
Code	Control	Safe-Off
N	Standard	N/A
C	Enhanced	No
G*	Enhanced	Yes

* Not available as factory installed option for 600V ratings.

l

Feedback	
Code	Feedback
N	NA - Standard Control
0	No Feedback - Enhanced Control
1	5V/12V Encoder w/Enhanced Control

Factory Installed Options

Conformal Coat

Printed circuit boards are coated with HumiSeal 1B73 acrylic coating to provide improved resistance to dust and moisture. Consult factory for additional details.

Description		A
Flange Mount Front: IP20, NEMA/UL Type 1 Back/Heatsink: IP66, NEMA/UL Type 4X/12 with Conformal Coat	L	B
		C
		D
		E
		A
Panel Mount IP20, NEMA/UL Type 1 with Conformal Coat	M	B
		C
		D
		E
		A

Human Interface and Wireless Interface Modules (Pos. e) IP20, NEMA/UL Type 1 and Flange Type Drives



Cat. Code: 0
No HIM (Blank Plate)



Cat. Code: 3
LCD Display, Full Numeric Keypad



Cat. Code: 5
LCD Display, Programmer Only

IP66, NEMA/UL Type 4X/12 Drives (Position e)



Cat. Code: 0
No HIM (Blank)



Cat. Code: 3
LCD Display, Full Numeric Keypad



Cat. Code: 5
LCD Display, Programmer Only



Cat. Code: 8
Wireless Interface Module

Documentation

Description	Cat. Code (Position f)
English User Manual, Multi-Language Quick Start	A
No User Manual	N

Internal Dynamic Brake Resistors

Drive Input Voltage	Brake Resistance Ω	Frame	Cat. Code
			(Position h)
200...240V ac	62	A	Y
		B	Y
		C	Y
	22	D	Y
		E	Not Available
380...480V ac	115	A	Y
		B	Y
		C	Y
	62	D	Y
		E	Not Available
600V ac	115	A	Y
		B	Y
		C	Y
	D & E	D & E	Not Available

These resistors have a limited duty cycle. Refer to the PowerFlex Dynamic Braking Selection Guide to determine if an internal resistor will be sufficient. An external resistor may be required.

Internal EMC Filter

Drive Input Voltage	CE Filter	Frame*	Cat. Code
			(Position i)
200...240V ac	Optional	B	A
	Standard	C	
	Standard	D	
380...480V ac	Optional	B	A
	Standard	C	
	Standard	D	
	Standard	E	

* Internal CE filters are not available for PowerFlex 70 A Frame drives. If an A Frame rating is ordered with an internal filter option, it will be supplied in a B Frame.

Internal Communication Adapters

Description	Cat. Code (Position j)
BACnet® MS/TP RS485 Communication Adapter	B
ControlNet™ Communication Adapter (Coax)	C
DeviceNet™ Communication Adapter	D
EtherNet/IP™ Communication Adapter	E
Remote I/O Communication Adapter	R
RS485 DF1 Communication Adapter	S

Control Options

Description	Cat. Code (Position <i>k</i>)
Enhanced Control without DriveGuard	C
Enhanced Control with DriveGuard	G
Standard Control	N

Feedback Options

Description	Cat. Code (Position <i>l</i>)
None (Standard Control)	N
None (Enhanced Control)	0
5V/12V Encoder (Enhanced Control)	1

User Installed Options

Human Interface and Wireless Interface Modules



No HIM (Blank Plate)
20-HIM-A0



LCD Display, Full
Numeric Keypad
20-HIM-A3



LCD Display,
Programmer Only
20-HIM-A5



Wireless Interface
Module
20-WIM-N1



Remote (Panel Mount)
LCD Display, Full
Numeric Keypad
20-HIM-C3S



Remote (Panel Mount)
LCD Display,
Programmer Only
20-HIM-C5S



Remote (Panel Mount)
Wireless Interface
Module
20-WIM-N4S

Description	Handheld/Local (Drive Mount)	Remote (Panel Mount) IP66, NEMA/UL Type 4x/12 *
	Cat. No.	Cat. No.
No HIM (Blank Plate)	20-HIM-A0	-
LCD Display, Full Numeric Keypad	20-HIM-A3	20-HIM-C3S ‡
LCD Display, Programmer Only	20-HIM-A5	20-HIM-C5S ‡
Wireless Interface Module	20-WIM-N1	20-WIM-N4S

* For indoor use only.

‡ Includes a 1202-C30 interface cable (3 meters) for connection to drive.

Human Interface Module Accessories

Description	Cat. No.
Bezel Kit for LCD HIMs, NEMA/UL Type 1 ‡	20-HIM-B1
PowerFlex HIM Interface Cable, 1 m (39 in) ?	20-HIM-H10
Cable Kit (Male-Female) ➤	
0.33 Meters (1.1 Feet)	1202-H03
1 Meter (3.3 Feet)	1202-H10
3 Meter (9.8 Feet)	1202-H30
9 Meter (29.5 Feet)	1202-H90
Comm Option Cable Kit	
0.33 Meters (1.1 Feet)	1202-C03
1 Meter (3.3 Feet)	1202-C10
3 Meter (9.8 Feet)	1202-C30
9 Meter (29.5 Feet)	1202-C90
DPI Cable Kit with Connectors, Tools and 100 m (328 ft.) Cable	1202-CBL-KIT-100M
DPI Cable Connector Kit	1202-TB-KIT-SET
DPI/SCANport™ One to Two Port Splitter Cable	1203-S03

‡ Includes a 1202-C30 interface cable (3 meters) for connection to drive.

? Required only when HIM is used as handheld or remote.

➤ Required in addition to 20-HIM-H10 for distances up to a total maximum of 10 Meters (32.8 Feet).

Dynamic Brake Resistors

Small Duty Internal Dynamic Brake Resistors

Limited duty resistors mount directly to the back surface of the drive and require no extra panel space. Internal resistors are non-destructive and do not require a resistor overheat external safety circuit.

PowerFlex 70 AC Drive			Small Duty Internal DB Resistor								
Normal Duty* kW (Hp)	Heavy Duty* kW (Hp)	Min DB Res Ohms ±10%	Part Number	Resistance * Ohms ±5%	Continuous Power kW	Max Energy kJ	Max Braking Torque % of ND Motor	Application Type 1		Application Type 2	
								Braking Torque % of ND Motor	Duty Cycle	Braking Torque % of ND Motor	Duty Cycle
200...240 Volt ac Input Drives											
0.37 (0.5)	0.25 (0.33)	33	20AB-DB1-A	62	0.048	8.3	307%	100%	25.9%	150%	17.3%
0.75 (1.0)	0.55 (0.75)	33	20AB-DB1-A	62	0.048	7.3	300%	100%	12.8%	150%	8.5%
1.5 (2.0)	1.1 (1.5)	33	20AB-DB1-B	62	0.028	0.8	160%	100%	3.7%	150%	2.5%
2.2 (3.0)	1.5 (2.0)	33	20AB-DB1-B	62	0.028	0.8	109%	100%	2.5%	109%	2.3%
4.0 (5.0)	3.0 (3.0)	30	20AB-DB1-C	62	0.040	0.8	60%	60%	3.3%	N/A	N/A
5.5 (7.5)	4.0 (5.0)	21	20AB-DB1-D	22	0.036	0.9	117%	100%	1.3%	117%	1.1%
7.5 (10)	5.5 (7.5)	21	20AB-DB1-D	22	0.036	0.9	86%	86%	1.1%	N/A	N/A
400...480 Volt ac Input Drives											
0.37 (0.5)	0.25 (0.33)	68	20AD-DB1-A	115	0.048	8.3	320%	100%	25.9%	150%	17.3%
0.75 (1.0)	0.55 (0.75)	68	20AD-DB1-A	115	0.048	9.0	259%	100%	12.8%	150%	8.5%
1.5 (2.0)	1.1 (1.5)	68	20AD-DB1-A	115	0.048	2.4	243%	100%	6.4%	150%	4.3%
2.2 (3.0)	1.5 (2.0)	68	20AD-DB1-B	115	0.028	0.9	206%	100%	2.5%	150%	1.7%
4.0 (5.0)	3.0 (3.0)	68	20AD-DB1-B	115	0.028	0.9	129%	100%	1.4%	129%	1.1%
5.5 (7.5)	4.0 (5.0)	74	20AD-DB1-C	115	0.04	0.9	94%	94%	1.5%	N/A	N/A
7.5 (10)	5.5 (7.5)	74	20AD-DB1-C	115	0.04	0.9	69%	69%	1.5%	N/A	N/A
11 (15)	7.5 (10)	44	20AD-DB1-D	62	0.036	0.8	87%	87%	0.8%	N/A	N/A
15 (20)	11 (15)	31	20AD-DB1-D	62	0.036	0.8	64%	64%	0.8%	N/A	N/A
500...600 Volt ac Input Drives											
0.37 (0.5)	0.25 (0.33)	117	20AD-DB1-A	115	0.048	8.3	287%	100%	25.9%	150%	17.3%
0.75 (1.0)	0.55 (0.75)	117	20AD-DB1-A	115	0.048	9.0	263%	100%	12.8%	150%	8.5%
1.5 (2.0)	1.1 (1.5)	117	20AD-DB1-A	115	0.048	2.4	243%	100%	6.4%	150%	4.3%
2.2 (3.0)	1.5 (2.0)	117	20AD-DB1-B	115	0.028	0.9	202%	100%	2.5%	150%	1.7%
4.0 (5.0)	3.0 (3.0)	80	20AD-DB1-B	115	0.028	0.9	193%	100%	1.4%	150%	0.9%
5.5 (7.5)	4.0 (5.0)	80	20AD-DB1-C	115	0.04	0.9	147%	100%	1.5%	147%	1.0%
7.5 (10)	5.5 (7.5)	80	20AD-DB1-C	115	0.04	0.9	108%	100%	1.1%	108%	1.0%
11 (15)	7.5 (10)	48	N/A	N/A	N/A	N/A	N/A	N/A	N/A	N/A	N/A
15 (20)	11 (15)	48	N/A	N/A	N/A	N/A	N/A	N/A	N/A	N/A	N/A

* Duty cycle listed is based on full speed to zero speed deceleration. For constant regen at full speed, duty cycle capability is half of what is listed. Application Type 1 represents maximum capability up to 100% braking torque where possible. Application Type 2 represents more than 100% braking torque where possible, up to a maximum of 150%.

* Always check resistor ohms against minimum resistance for drive being used.

Internal Dynamic Brake Resistor Kits

Drive Input Voltage	Brake Resistance	Frame	Cat. No.
	Ω		
200...240V ac	62	A	20AB-DB1-A
		B	20AB-DB1-B
		C	20AB-DB1-C
	22	D	20AB-DB1-D
		E	Not Available
380...480V ac	115	A	20AD-DB1-A
		B	20AD-DB1-B
		C	20AD-DB1-C
	62	D	20AD-DB1-D
		E	Not Available
600V ac	115	A	20AD-DB1-A
		B	20AD-DB1-B
		C	20AD-DB1-C
	D & E	Not Available	

These resistors have a limited duty cycle. Refer to the PowerFlex Dynamic Braking Selection Guide to determine if an internal resistor will be sufficient. An external resistor may be required.

Medium Duty External Dynamic Brake Resistors

These resistors provide a larger duty cycle capability than the internal type. Includes an internal thermal switch for use in external safety circuit.

PowerFlex 70 AC Drive			Medium Duty External DB Resistor									
Normal Duty* kW (Hp)	Heavy Duty* kW (Hp)	Min DB Res Ohms ±10%	Part Number	Resistance * Ohms ±5%	Continuous Power kW	Max Energy kJ	Max Braking Torque % of ND Motor	Application Type 1		Application Type 2		
								Braking Torque % of ND Motor	Duty Cycle	Braking Torque % of ND Motor	Duty Cycle	
200...240 Volt ac Input Drives												
0.37 (0.5)	0.25 (0.33)	33	AK-R2-091P500	91	0.086	17	293%	100%	46%	150%	31%	
0.75 (1.0)	0.55 (0.75)	33	AK-R2-091P500	91	0.086	17	218%	100%	23%	150%	15%	
1.5 (2.0)	1.1 (1.5)	33	AK-R2-091P500	91	0.086	17	109%	100%	11%	109%	11%	
2.2 (3.0)	1.5 (2.0)	33	AK-R2-047P500	47	0.166	33	144%	100%	15%	144%	11%	
4.0 (5.0)	3.0 (3.0)	30	AK-R2-047P500	47	0.166	33	79%	79%	11%	N/A	N/A	
5.5 (7.5)	4.0 (5.0)	23	AK-R2-030P1K2	30	0.26	52	90%	90%	10%	N/A	N/A	
7.5 (10)	5.5 (7.5)	23	AK-R2-030P1K2	30	0.26	52	66%	66%	10%	N/A	N/A	
400...480 Volt ac Input Drives												
0.37 (0.5)	0.25 (0.33)	68	AK-R2-360P500	360	0.086	17	305%	100%	47%	150%	31%	
0.75 (1.0)	0.55 (0.75)	68	AK-R2-360P500	360	0.086	17	220%	100%	23%	150%	15%	
1.5 (2.0)	1.1 (1.5)	68	AK-R2-360P500	360	0.086	17	110%	100%	12%	110%	11%	
2.2 (3.0)	1.5 (2.0)	68	AK-R2-120P1K2	120	0.26	52	197%	100%	24%	150%	16%	
4.0 (5.0)	3.0 (3.0)	68	AK-R2-120P1K2	120	0.26	52	124%	100%	13%	124%	10%	
5.5 (7.5)	4.0 (5.0)	74	AK-R2-120P1K2	120	0.26	52	90%	90%	10%	N/A	N/A	
7.5 (10)	5.5 (7.5)	74	AK-R2-120P1K2	120	0.26	52	66%	66%	10%	N/A	N/A	
11 (15) ‡	7.5 (10) ‡	44	‡	60	0.52	104	90%	90%	10%	N/A	N/A	
15 (20) ‡	11 (15) ‡	31	‡	60	0.52	104	66%	66%	10%	N/A	N/A	
500...600 Volt ac Input Drives												
0.37 (0.5)	0.25 (0.33)	117	AK-R2-360P500	360	0.086	17	274%	100%	46%	150%	31%	
0.75 (1.0)	0.55 (0.75)	117	AK-R2-360P500	360	0.086	17	251%	100%	23%	150%	15%	
1.5 (2.0)	1.1 (1.5)	117	AK-R2-360P500	360	0.086	17	172%	100%	11%	150%	8%	
2.2 (3.0)	1.5 (2.0)	117	AK-R2-120P1K2	120	0.26	52	193%	100%	24%	150%	16%	
4.0 (5.0)	3.0 (3.0)	80	AK-R2-120P1K2	120	0.26	52	185%	100%	13%	150%	9%	
5.5 (7.5)	4.0 (5.0)	80	AK-R2-120P1K2	120	0.26	52	141%	100%	9%	141%	7%	
7.5 (10)	5.5 (7.5)	80	AK-R2-120P1K2	120	0.26	52	103%	100%	7%	103%	7%	
11 (15) ‡	7.5 (10) ‡	48	‡	60	0.52	104	141%	100%	9%	141%	7%	
15 (20) ‡	11 (15) ‡	48	‡	60	0.52	104	103%	100%	7%	103%	7%	

* Duty cycle listed is based on full speed to zero speed deceleration. For constant regen at full speed, duty cycle capability is half of what is listed. Application Type 1 represents maximum capability up to 100% braking torque where possible. Application Type 2 represents more than 100% braking torque where possible, up to a maximum of 150%.

‡ Always check resistor ohms against minimum resistance for drive being used.

‡ For 11 and 15 kW (15 and 20 Hp) applications, use two 7.5 kW (10 Hp) size resistors wired in parallel.

External Dynamic Brake Resistor Kits

Drive Input Voltage	Brake Resistance	Continuous Power	Cat. No.
	Ω	W	
200...240V ac	30	260	AK-R2-030P1K2
	47	166	AK-R2-047P500
	91	86	AK-R2-091P500
480...600V ac	120	260	AK-R2-120P1K2
	360	86	AK-R2-360P500

Communication Option Kits

Description	Cat. No.
BACnet® MS/TP RS485 Communication Adapter	20-COMM-B
ControlNet™ Communication Adapter (Coax)	20-COMM-C
ControlNet™ Communication Adapter (Coax) Conformal Coat	20-COMM-C-MX3
DeviceNet™ Communication Adapter	20-COMM-D
DeviceNet™ Communication Adapter Conformal Coat	20-COMM-D-MX3
EtherNet/IP™ Communication Adapter	20-COMM-E
EtherNet/IP™ Communication Adapter Conformal Coat	20-COMM-E-MX3
HVAC Communication Adapter	20-COMM-H
Interbus™ Communication Adapter	20-COMM-I
CANopen® Communication Adapter	20-COMM-K
LonWorks® Communication Adapter	20-COMM-L
Modbus/TCP Communication Adapter	20-COMM-M
PROFIBUS™ DP Communication Adapter	20-COMM-P
ControlNet™ Communication Adapter (Fiber)	20-COMM-Q
Remote I/O Communication Adapter	20-COMM-R
Remote I/O Communication Adapter Conformal Coat	20-COMM-R-MX3
RS485 DF1 Communication Adapter	20-COMM-S
RS485 DF1 Communication Adapter Conformal Coat	20-COMM-S-MX3
External Communications Kit Power Supply	20-XCOMM-AC-PS1
DPI External Communications Kit	20-XCOMM-DC-BASE
External DPI I/O Option Board †	20-XCOMM-IO-OPT1
Compact I/O Module (3 Channel)	1769-SM1
Serial Null Modem Adapter	1203-SNM
Smart Self-powered Serial Converter (RS232) includes 1203-SFC and 1202-C10 Cables	1203-SSS
Universal Serial Bus™ (USB) Converter includes 2m USB, 20-HIM-H10 & 22-HIM-H10 Cables	1203-USB

† For use only with DPI External Communications Kits 20-XCOMM-DC-BASE.

Other Options

Description	Cat. No.
DriveGuard® Safe-Off Board §	20A-DG01
5V/12V Encoder §	20A-ENC-1
115V ac Interface	AK-M9-115VAC-1
Frame E Flange Gasket	AK-M9-GASKET1-E4
Service Connection Board ‡	SK-M9-SCB1

§ Works only with PowerFlex 70 Enhanced Control.

‡ Provides temporary DPI/HIM connection for NEMA/UL Type 1 and Flange drives with cover removed.

Terminators

Description †	Cat. No.
for use with 3.7 kW (5 Hp) & below drives	1204-TFA1
for use with 1.5 kW (2 Hp) & up drives	1204-TFB2

† Refer to Appendix A of publication *DRIVES-IN001* for selection information.

Reflected Wave Reduction Modules

Description †	Cat. No.
17A with Common Mode Choke	1204-RWC-17-A
9A without Choke, Book Mount	1204-RWR2-09-B
9A without Choke, Stack Mount	1204-RWR2-09-C

† Refer to Appendix A of publication *DRIVES-IN001* for selection information.

PC Programming Software

Description	
DriveTools™ SP Software †	See publication PFLEX-SG002 for further information.
DriveExplorer™ Software (Lite/Full) † ‡	
Pocket DriveExplorer™ Software	

† Set-up wizards are available for use with DriveTools SP and DriveExplorer (Lite/Full) only.

‡ DriveExplorer Lite is available for free download at: http://www.ab.com/drives/driveexplorer/free_download.html.

Reflective Wave Reduction Devices

1321-RWR devices are used at the output of the drive to reduce dv/dt and motor terminal peak voltages

480V, 60 Hz, Three-Phase		
Drive Cat. No.	KW (Hp)	RWR Filter Cat. No.
20AD1P1-ND	0.37 (0.5)	–
20AD2P1-ND	0.75 (1.0)	–
20AD3P4-ND	1.5 (2.0)	–
20AD5P0-ND	2.2 (3.0)	–
20AD8P0-ND	4.0 (5.0)	1321-RWR8-DP
20AD011-ND	5.5 (7.5)	1321-RWR12-DP
20AD014-ND	7.5 (10)	1321-RWR18-DP
20AD022-ND	11 (15)	1321-RWR25-DP
20AD027-ND	15 (20)	1321-RWR35-DP
20AD034-ND	18.5 (25)	1321-RWR35-DP
20AD040-ND	22 (30)	1321-RWR45-DP
20AD052-ND	30 (40)	1321-RWR55-DP
20AD065-ND	37 (50)	1321-RWR80-DP

600V, 60 Hz, Three-Phase		
Drive Cat. No.	KW (Hp)	RWR Filter Cat. No.
20AE0P9-ND	0.37 (0.5)	–
20AE1P7-ND	0.75 (1.0)	–
20AE2P7-ND	1.5 (2.0)	–
20AE3P9-ND	2.2 (3.0)	–
20AE6P1-ND	4.0 (5.0)	1321-RWR8-EP
20AE9P0-ND	5.5 (7.5)	1321-RWR12-EP
20AE011-ND	7.5 (10)	1321-RWR18-EP
20AE017-ND	11 (15)	1321-RWR25-EP
20AE022-ND	15 (20)	1321-RWR35-EP
20AE027-ND	18.5 (25)	1321-RWR45-EP
20AE032-ND	22 (30)	1321-RWR55-EP
20AE041-ND	30 (40)	1321-RWR80-EP
20AE052-ND	37 (50)	1321-RWR100-EP

Isolation Transformers

For installations that have specific types of AC supply configurations or require drive protection due to AC line disturbances, isolation transformers are available.

Motor Rating kW (Hp)	240V, 60 Hz, Three-Phase, 240V Primary & 240V Secondary	460V, 60 Hz, Three-Phase, 460V Primary & 460V Secondary	575V, 60 Hz, Three-Phase 575V Primary & 575V Secondary
	IP32 (NEMA/UL Type 3R)	IP32 (NEMA/UL Type 3R)	IP32 (NEMA/UL Type 3R)
	Cat. No.	Cat. No.	Cat. No.
0.25 (0.33)	1321-3TW005-AA	1321-3TW005-BB	–
0.37 (0.5)	1321-3TW005-AA	1321-3TW005-BB	–
0.55 (0.75)	1321-3TW005-AA	1321-3TW005-BB	–
0.75 (1.0)	1321-3TW005-AA	1321-3TW005-BB	1321-3TW005-CC
1.1 (1.5)	1321-3TW005-AA	1321-3TW005-BB	–
1.5 (2.0)	1321-3TW005-AA	1321-3TW005-BB	1321-3TW005-CC
2.2 (3.0)	1321-3TW005-AA	1321-3TW005-BB	1321-3TW005-CC
4.0 (5.0)	1321-3TW007-AA	1321-3TW007-BB	1321-3TW007-CC
5.5 (7.5)	1321-3TW011-AA	1321-3TW011-BB	1321-3TW011-CC
7.5 (10)	1321-3TW014-AA	1321-3TW014-BB	1321-3TW014-CC
11 (15)	1321-3TW020-AA	1321-3TW020-BB	1321-3TW020-CC
15 (20)	1321-3TW027-AA	1321-3TW027-BB	1321-3TW027-CC
18.5 (25)	1321-3TW034-AA	1321-3TW034-BB	1321-3TW034-CC
22 (30)	–	1321-3TW040-BB	1321-3TW040-CC
30 (40)	–	1321-3TW051-BB	1321-3TW051-CC
37 (50)	–	1321-3TH063-BB	1321-3TH063-CC

EMC Filters

These external filters are only for Frame A drives. Other drive frames are available with internal filters. See Factory Installed Options.

Description	Frame	Cat. No.
External 1-Phase 200...240V, 8A Filter	A	20A-RF-08-A1
External 3-Phase 200...480V, 5A Filter	A	20A-RF-05-A3

Input/Output Line Reactors

For impedance matching, protection from AC line disturbances or motor protection, reactors are available for both the input and output sides of the drive.

240V, 60 Hz, Three-Phase, 3% Impedance

Drive Cat. No.	Duty	Hp	Input Line Reactor ⁽¹⁾		Output Line Reactor ⁽¹⁾	
			IP00 (NEMA/UL Type Open)	IP11 (NEMA/UL Type 1)	IP00 (NEMA/UL Type Open)	IP11 (NEMA/UL Type 1)
			Cat. No.	Cat. No.	Cat. No.	Cat. No.
20AB2P2	Heavy Duty	0.33	1321-3R2-D	1321-3RA2-D	1321-3R2-D	1321-3RA2-D
20AB2P2	Normal Duty	0.5	1321-3R2-D	1321-3RA2-D	1321-3R2-D	1321-3RA2-D
20AB4P2	Heavy Duty	0.75	1321-3R4-A	1321-3RA4-A	1321-3R4-A	1321-3RA4-A
20AB4P2	Normal Duty	1	1321-3R4-A	1321-3RA4-A	1321-3R4-A	1321-3RA4-A
20AB6P8	Heavy Duty	1.5	1321-3R8-B	1321-3RA8-B	1321-3R8-A	1321-3RA8-A
20AB6P8	Normal Duty	2	1321-3R8-A	1321-3RA8-A	1321-3R8-A	1321-3RA8-A
20AB9P6	Heavy Duty	2	1321-3R8-A	1321-3RA8-A	1321-3R12-A	1321-3RA12-A
20AB9P6	Normal Duty	3	1321-3R12-A	1321-3RA12-A	1321-3R12-A	1321-3RA12-A
20AB015	Heavy Duty	3	1321-3R12-A	1321-3RA12-A	1321-3R18-A	1321-3RA18-A
20AB015	Normal Duty	5	1321-3R18-A	1321-3RA18-A	1321-3R18-A	1321-3RA18-A
20AB022	Heavy Duty	5	1321-3R18-A	1321-3RA18-A	1321-3R25-A	1321-3RA25-A
20AB022	Normal Duty	7.5	1321-3R25-A	1321-3RA25-A	1321-3R25-A	1321-3RA25-A
20AB028	Heavy Duty	7.5	1321-3R25-A	1321-3RA25-A	1321-3R35-A	1321-3RA35-A
20AB028	Normal Duty	10	1321-3R35-A	1321-3RA35-A	1321-3R35-A	1321-3RA35-A
20AB042	Heavy Duty	10	1321-3R35-A	1321-3RA35-A	1321-3R45-A	1321-3RA45-A
20AB042	Normal Duty	15	1321-3R45-A	1321-3RA45-A	1321-3R45-A	1321-3RA45-A
20AB054	Heavy Duty	15	1321-3R45-A	1321-3RA45-A	1321-3R55-A	1321-3RA55-A
20AB054	Normal Duty	20	1321-3R55-A	1321-3RA55-A	1321-3R55-A	1321-3RA55-A
20AB070	Heavy Duty	20	1321-3R55-A	1321-3RA55-A	1321-3R80-A	1321-3RA80-A
20AB070	Normal Duty	25	1321-3R80-A	1321-3RA80-A	1321-3R80-A	1321-3RA80-A

⁽¹⁾ Input line reactors were sized based on the NEC fundamental motor amps. Output line reactors were sized based on the VFD rated output currents.

240V, 60 Hz, Three-Phase, 5% Impedance

Drive Cat. No.	Duty	Hp	Input Line Reactor ⁽¹⁾		Output Line Reactor ⁽¹⁾	
			IP00 (NEMA/UL Type Open)	IP11 (NEMA/UL Type 1)	IP00 (NEMA/UL Type Open)	IP11 (NEMA/UL Type 1)
			Cat. No.	Cat. No.	Cat. No.	Cat. No.
20AB2P2	Heavy Duty	0.33	1321-3R2-A	1321-3RA2-A	1321-3R2-A	1321-3RA2-A
20AB2P2	Normal Duty	0.5	1321-3R2-A	1321-3RA2-A	1321-3R2-A	1321-3RA2-A
20AB4P2	Heavy Duty	0.75	1321-3R4-B	1321-3RA4-B	1321-3R4-B	1321-3RA4-B
20AB4P2	Normal Duty	1	1321-3R4-B	1321-3RA4-B	1321-3R4-B	1321-3RA4-B
20AB6P8	Heavy Duty	1.5	1321-3R8-B	1321-3RA8-B	1321-3R8-B	1321-3RA8-B
20AB6P8	Normal Duty	2	1321-3R8-B	1321-3RA8-B	1321-3R8-B	1321-3RA8-B
20AB9P6	Heavy Duty	2	1321-3R8-B	1321-3RA8-B	1321-3R12-B	1321-3RA12-B
20AB9P6	Normal Duty	3	1321-3R12-B	1321-3RA12-B	1321-3R12-B	1321-3RA12-B
20AB015	Heavy Duty	3	1321-3R12-B	1321-3RA12-B	1321-3R18-B	1321-3RA18-B
20AB015	Normal Duty	5	1321-3R18-B	1321-3RA18-B	1321-3R18-B	1321-3RA18-B
20AB022	Heavy Duty	5	1321-3R18-B	1321-3RA18-B	1321-3R25-B	1321-3RA25-B
20AB022	Normal Duty	7.5	1321-3R25-B	1321-3RA25-B	1321-3R25-B	1321-3RA25-B
20AB028	Heavy Duty	7.5	1321-3R25-B	1321-3RA25-B	1321-3R35-B	1321-3RA35-B
20AB028	Normal Duty	10	1321-3R35-B	1321-3RA35-B	1321-3R35-B	1321-3RA35-B
20AB042	Heavy Duty	10	1321-3R35-B	1321-3RA35-B	1321-3R45-B	1321-3RA45-B
20AB042	Normal Duty	15	1321-3R45-B	1321-3RA45-B	1321-3R45-B	1321-3RA45-B
20AB054	Heavy Duty	15	1321-3R45-B	1321-3RA45-B	1321-3R55-B	1321-3RA55-B
20AB054	Normal Duty	20	1321-3R55-B	1321-3RA55-B	1321-3R55-B	1321-3RA55-B
20AB070	Heavy Duty	20	1321-3R55-B	1321-3RA55-B	1321-3R80-B	1321-3RA80-B
20AB070	Normal Duty	25	1321-3R80-B	1321-3RA80-B	1321-3R80-B	1321-3RA80-B

⁽¹⁾ Input line reactors were sized based on the NEC fundamental motor amps. Output line reactors were sized based on the VFD rated output currents.

480V, 60 Hz, Three-Phase, 3% Impedance

Drive Cat. No.	Duty	Hp	Input Line Reactor ⁽¹⁾		Output Line Reactor ⁽¹⁾	
			IP00 (NEMA/UL Type Open)	IP11 (NEMA/UL Type 1)	IP00 (NEMA/UL Type Open)	IP11 (NEMA/UL Type 1)
			Cat. No.	Cat. No.	Cat. No.	Cat. No.
20AD1P1	Heavy Duty	0.33	1321-3R1-C	1321-3RA1-C	1321-3R2-B	1321-3RA2-B
20AD1P1	Normal Duty	0.5	1321-3R1-C	1321-3RA1-C	1321-3R2-B	1321-3RA2-B
20AD2P1	Heavy Duty	0.75	1321-3R2-A	1321-3RA2-A	1321-3R2-A	1321-3RA2-A
20AD2P1	Normal Duty	1	1321-3R2-A	1321-3RA2-A	1321-3R2-A	1321-3RA2-A
20AD3P4	Heavy Duty	1.5	1321-3R4-C	1321-3RA4-C	1321-3R4-B	1321-3RA4-B
20AD3P4	Normal Duty	2	1321-3R4-B	1321-3RA4-B	1321-3R4-B	1321-3RA4-B
20AD5P0	Heavy Duty	2	1321-3R4-B	1321-3RA4-B	1321-3R8-C	1321-3RA8-C
20AD5P0	Normal Duty	3	1321-3R8-C	1321-3RA8-C	1321-3R8-C	1321-3RA8-C
20AD8P0	Heavy Duty	3	1321-3R8-C	1321-3RA8-C	1321-3R8-B	1321-3RA8-B
20AD8P0	Normal Duty	5	1321-3R8-B	1321-3RA8-B	1321-3R8-B	1321-3RA8-B
20AD011	Heavy Duty	5	1321-3R8-B	1321-3RA8-B	1321-3R12-B	1321-3RA12-B
20AD011	Normal Duty	7.5	1321-3R12-B	1321-3RA12-B	1321-3R12-B	1321-3RA12-B
20AD014	Heavy Duty	7.5	1321-3R12-B	1321-3RA12-B	1321-3R18-B	1321-3RA18-B
20AD014	Normal Duty	10	1321-3R18-B	1321-3RA18-B	1321-3R18-B	1321-3RA18-B
20AD022	Heavy Duty	10	1321-3R18-B	1321-3RA18-B	1321-3R25-B	1321-3RA25-B
20AD022	Normal Duty	15	1321-3R25-B	1321-3RA25-B	1321-3R25-B	1321-3RA25-B
20AD027	Heavy Duty	15	1321-3R25-B	1321-3RA25-B	1321-3R25-B	1321-3RA25-B
20AD027	Normal Duty	20	1321-3R35-B	1321-3RA35-B	1321-3R25-B	1321-3RA25-B
20AD034	Heavy Duty	20	1321-3R35-B	1321-3RA35-B	1321-3R35-B	1321-3RA35-B
20AD034	Normal Duty	25	1321-3R35-B	1321-3RA35-B	1321-3R35-B	1321-3RA35-B
20AD040	Heavy Duty	25	1321-3R35-B	1321-3RA35-B	1321-3R45-B	1321-3RA45-B
20AD040	Normal Duty	30	1321-3R45-B	1321-3RA45-B	1321-3R45-B	1321-3RA45-B
20AD052	Heavy Duty	30	1321-3R45-B	1321-3RA45-B	1321-3R55-B	1321-3RA55-B
20AD052	Normal Duty	40	1321-3R55-B	1321-3RA55-B	1321-3R55-B	1321-3RA55-B
20AD065	Heavy Duty	40	1321-3R55-B	1321-3RA55-B	1321-3R80-B	1321-3RA80-B
20AD065	Normal Duty	50	1321-3R80-B	1321-3RA80-B	1321-3R80-B	1321-3RA80-B

⁽¹⁾ Input line reactors were sized based on the NEC fundamental motor amps. Output line reactors were sized based on the VFD rated output currents.

480V, 60 Hz, Three-Phase, 5% Impedance

Drive Cat. No.	Duty	Hp	Input Line Reactor ⁽¹⁾		Output Line Reactor ⁽¹⁾	
			IP00 (NEMA/UL Type Open)	IP11 (NEMA/UL Type 1)	IP00 (NEMA/UL Type Open)	IP11 (NEMA/UL Type 1)
			Cat. No.	Cat. No.	Cat. No.	Cat. No.
20AD1P1	Heavy Duty	0.33	1321-3R1-B	1321-3RA1-B	1321-3R2-C	1321-3RA2-C
20AD1P1	Normal Duty	0.5	1321-3R1-B	1321-3RA1-B	1321-3R2-C	1321-3RA2-C
20AD2P1	Heavy Duty	0.75	1321-3R2-C	1321-3RA2-C	1321-3R2-B	1321-3RA2-B
20AD2P1	Normal Duty	1	1321-3R2-B	1321-3RA2-B	1321-3R2-B	1321-3RA2-B
20AD3P4	Heavy Duty	1.5	1321-3R4-D	1321-3RA4-D	1321-3R4-D	1321-3RA4-D
20AD3P4	Normal Duty	2	1321-3R4-D	1321-3RA4-D	1321-3R4-D	1321-3RA4-D
20AD5P0	Heavy Duty	2	1321-3R4-D	1321-3RA4-D	1321-3R8-D	1321-3RA8-D
20AD5P0	Normal Duty	3	1321-3R8-D	1321-3RA8-D	1321-3R8-D	1321-3RA8-D
20AD8P0	Heavy Duty	3	1321-3R8-D	1321-3RA8-D	1321-3R8-C	1321-3RA8-C
20AD8P0	Normal Duty	5	1321-3R8-C	1321-3RA8-C	1321-3R8-C	1321-3RA8-C
20AD011	Heavy Duty	5	1321-3R8-C	1321-3RA8-C	1321-3R12-C	1321-3RA12-C
20AD011	Normal Duty	7.5	1321-3R12-C	1321-3RA12-C	1321-3R12-C	1321-3RA12-C
20AD014	Heavy Duty	7.5	1321-3R12-C	1321-3RA12-C	1321-3R18-C	1321-3RA18-C
20AD014	Normal Duty	10	1321-3R18-C	1321-3RA18-C	1321-3R18-C	1321-3RA18-C
20AD022	Heavy Duty	10	1321-3R18-C	1321-3RA18-C	1321-3R25-C	1321-3RA25-C
20AD022	Normal Duty	15	1321-3R25-C	1321-3RA25-C	1321-3R25-C	1321-3RA25-C
20AD027	Heavy Duty	15	1321-3R25-C	1321-3RA25-C	1321-3R25-C	1321-3RA25-C
20AD027	Normal Duty	20	1321-3R35-C ⁽²⁾	1321-3RA35-C ⁽²⁾	1321-3R25-C	1321-3RA25-C
20AD034	Heavy Duty	20	1321-3R35-C ⁽²⁾	1321-3RA35-C ⁽²⁾	1321-3R35-C	1321-3RA35-C
20AD034	Normal Duty	25	1321-3R35-C	1321-3RA35-C	1321-3R35-C	1321-3RA35-C
20AD040	Heavy Duty	25	1321-3R35-C	1321-3RA35-C	1321-3R45-C	1321-3RA45-C
20AD040	Normal Duty	30	1321-3R45-C	1321-3RA45-C	1321-3R45-C	1321-3RA45-C
20AD052	Heavy Duty	30	1321-3R45-C	1321-3RA45-C	1321-3R55-C	1321-3RA55-C
20AD052	Normal Duty	40	1321-3R55-C	1321-3RA55-C	1321-3R55-C	1321-3RA55-C
20AD065	Heavy Duty	40	1321-3R55-C	1321-3RA55-C	1321-3R80-C	1321-3RA80-C
20AD065	Normal Duty	50	1321-3R80-C	1321-3RA80-C	1321-3R80-C	1321-3RA80-C

⁽¹⁾ Input line reactors were sized based on the NEC fundamental motor amps. Output line reactors were sized based on the VFD rated output currents.

⁽²⁾ 4% impedance.

PowerFlex 70 Technical Data

600V, 60 Hz, Three-Phase, 3% Impedance

Drive Cat. No.	Duty	Hp	Input Line Reactor ⁽¹⁾		Output Line Reactor ⁽¹⁾	
			IP00 (NEMA/UL Type Open)	IP11 (NEMA/UL Type 1)	IP00 (NEMA/UL Type Open)	IP11 (NEMA/UL Type 1)
			Cat. No.	Cat. No.	Cat. No.	Cat. No.
20AE0P9	Heavy Duty	0.33	1321-3R1-C	1321-3RA1-C	1321-3R1-B	1321-3RA1-B
20AE0P9	Normal Duty	0.5	1321-3R1-C	1321-3RA1-C	1321-3R1-B	1321-3RA1-B
20AE1P7	Heavy Duty	0.75	1321-3R2-B	1321-3RA2-B	1321-3R2-B	1321-3RA2-B
20AE1P7	Normal Duty	1	1321-3R2-B	1321-3RA2-B	1321-3R2-B	1321-3RA2-B
20AE2P7	Heavy Duty	1.5	1321-3R2-A	1321-3RA2-A	1321-3R4-D	1321-3RA4-D
20AE2P7	Normal Duty	2	1321-3R4-C	1321-3RA4-C	1321-3R4-D	1321-3RA4-D
20AE3P9	Heavy Duty	2	1321-3R4-C	1321-3RA4-C	1321-3R4-C	1321-3RA4-C
20AE3P9	Normal Duty	3	1321-3R4-C	1321-3RA4-C	1321-3R4-C	1321-3RA4-C
20AE6P1	Heavy Duty	3	1321-3R4-C	1321-3RA4-C	1321-3R8-C	1321-3RA8-C
20AE6P1	Normal Duty	5	1321-3R8-C	1321-3RA8-C	1321-3R8-C	1321-3RA8-C
20AE9P0	Heavy Duty	5	1321-3R8-C	1321-3RA8-C	1321-3R12-C	1321-3RA12-C
20AE9P0	Normal Duty	7.5	1321-3R12-C	1321-3RA12-C	1321-3R12-C	1321-3RA12-C
20AE011	Heavy Duty	7.5	1321-3R12-C	1321-3RA12-C	1321-3R12-B	1321-3RA12-B
20AE011	Normal Duty	10	1321-3R12-B	1321-3RA12-B	1321-3R12-B	1321-3RA12-B
20AE017	Heavy Duty	10	1321-3R12-B	1321-3RA12-B	1321-3R18-B	1321-3RA18-B
20AE017	Normal Duty	15	1321-3R18-B	1321-3RA18-B	1321-3R18-B	1321-3RA18-B
20AE022	Heavy Duty	15	1321-3R18-B	1321-3RA18-B	1321-3R25-B	1321-3RA25-B
20AE022	Normal Duty	20	1321-3R25-B	1321-3RA25-B	1321-3R25-B	1321-3RA25-B
20AE027	Heavy Duty	20	1321-3R25-B	1321-3RA25-B	1321-3R35-C	1321-3RA35-C
20AE027	Normal Duty	25	1321-3R35-C	1321-3RA35-C	1321-3R35-C	1321-3RA35-C
20AE032	Heavy Duty	25	1321-3R35-C	1321-3RA35-C	1321-3R35-B	1321-3RA35-B
20AE032	Normal Duty	30	1321-3R35-B	1321-3RA35-B	1321-3R35-B	1321-3RA35-B
20AE041	Heavy Duty	30	1321-3R35-B	1321-3RA35-B	1321-3R45-B	1321-3RA45-B
20AE041	Normal Duty	40	1321-3R45-B	1321-3RA45-B	1321-3R45-B	1321-3RA45-B
20AE052	Heavy Duty	40	1321-3R45-B	1321-3RA45-B	1321-3R55-B	1321-3RA55-B
20AE052	Normal Duty	50	1321-3R55-B	1321-3RA55-B	1321-3R55-B	1321-3RA55-B

⁽¹⁾ Input line reactors were sized based on the NEC fundamental motor amps. Output line reactors were sized based on the VFD rated output currents.

600V, 60 Hz, Three-Phase, 5% Impedance

Drive Cat. No.	Duty	Hp	Input Line Reactor ⁽¹⁾		Output Line Reactor ⁽¹⁾	
			IP00 (NEMA/UL Type Open)	IP11 (NEMA/UL Type 1)	IP00 (NEMA/UL Type Open)	IP11 (NEMA/UL Type 1)
			Cat. No.	Cat. No.	Cat. No.	Cat. No.
20AE0P9	Heavy Duty	0.33	1321-3R1-A	1321-3RA1-A	1321-3R1-B	1321-3RA1-B
20AE0P9	Normal Duty	0.5	1321-3R1-B	1321-3RA1-B	1321-3R1-B	1321-3RA1-B
20AE1P7	Heavy Duty	0.5	1321-3R1-B	1321-3RA1-B	1321-3R2-C	1321-3RA2-C
20AE1P7	Normal Duty	1	1321-3R2-C	1321-3RA2-C	1321-3R2-C	1321-3RA2-C
20AE2P7	Heavy Duty	1	1321-3R2-C	1321-3RA2-C	1321-3R4-D ⁽²⁾	1321-3RA4-D ⁽²⁾
20AE2P7	Normal Duty	2	1321-3R4-D ⁽²⁾	1321-3RA4-D ⁽²⁾	1321-3R4-D ⁽²⁾	1321-3RA4-D ⁽²⁾
20AE3P9	Heavy Duty	2	1321-3R4-D ⁽²⁾	1321-3RA4-D ⁽²⁾	1321-3R4-D	1321-3RA4-D
20AE3P9	Normal Duty	3	1321-3R4-D	1321-3RA4-D	1321-3R4-D	1321-3RA4-D
20AE6P1	Heavy Duty	3	1321-3R4-D	1321-3RA4-D	1321-3R8-D	1321-3RA8-D
20AE6P1	Normal Duty	5	1321-3R8-D	1321-3RA8-D	1321-3R8-D	1321-3RA8-D
20AE9P0	Heavy Duty	5	1321-3R8-D	1321-3RA8-D	1321-3R12-C ⁽²⁾	1321-3RA12-C ⁽²⁾
20AE9P0	Normal Duty	7.5	1321-3R12-C ⁽²⁾	1321-3RA12-C ⁽²⁾	1321-3R12-C ⁽²⁾	1321-3RA12-C ⁽²⁾
20AE011	Heavy Duty	7.5	1321-3R12-C ⁽²⁾	1321-3RA12-C ⁽²⁾	1321-3R12-C	1321-3RA12-C
20AE011	Normal Duty	10	1321-3R12-C	1321-3RA12-C	1321-3R12-C	1321-3RA12-C
20AE017	Heavy Duty	10	1321-3R12-C	1321-3RA12-C	1321-3R18-C	1321-3RA18-C
20AE017	Normal Duty	15	1321-3R18-C	1321-3RA18-C	1321-3R18-C	1321-3RA18-C
20AE022	Heavy Duty	15	1321-3R18-C	1321-3RA18-C	1321-3R25-C ⁽²⁾	1321-3RA25-C ⁽²⁾
20AE022	Normal Duty	20	1321-3R25-C ⁽²⁾	1321-3RA25-C ⁽²⁾	1321-3R25-C ⁽²⁾	1321-3RA25-C ⁽²⁾
20AE027	Heavy Duty	20	1321-3R25-C ⁽²⁾	1321-3RA25-C ⁽²⁾	1321-3R35-C ⁽²⁾	1321-3RA35-C ⁽²⁾
20AE027	Normal Duty	25	1321-3R35-C ⁽²⁾	1321-3RA35-C ⁽²⁾	1321-3R35-C ⁽²⁾	1321-3RA35-C ⁽²⁾
20AE032	Heavy Duty	25	1321-3R35-C ⁽²⁾	1321-3RA35-C ⁽²⁾	1321-3R35-C ⁽²⁾	1321-3RA35-C ⁽²⁾
20AE032	Normal Duty	30	1321-3R35-C ⁽²⁾	1321-3RA35-C ⁽²⁾	1321-3R35-C ⁽²⁾	1321-3RA35-C ⁽²⁾
20AE041	Heavy Duty	30	1321-3R35-C ⁽²⁾	1321-3RA35-C ⁽²⁾	1321-3R45-C	1321-3RA45-C
20AE041	Normal Duty	40	1321-3R45-C	1321-3RA45-C	1321-3R45-C	1321-3RA45-C
20AE052	Heavy Duty	40	1321-3R45-C	1321-3RA45-C	1321-3R55-C	1321-3RA55-C
20AE052	Normal Duty	50	1321-3R55-C	1321-3RA55-C	1321-3R55-C	1321-3RA55-C

⁽¹⁾ Input line reactors were sized based on the NEC fundamental motor amps. Output line reactors were sized based on the VFD rated output currents.

⁽²⁾ 4% impedance.

Installation Considerations

Power Wiring

The PowerFlex 70 has the following built in protective features to help simplify installation:

- Ground fault protection during start-up and running helps ensure reliability
- Electronic motor overload protection increases motor life
- Removable MOV to ground and common mode capacitors to ground ensure compatibility with ungrounded systems. These devices must be disconnected if the drive is installed on an ungrounded, high-resistance or B phase grounded distribution system. These devices must also be disconnected if a regenerative unit is used as a bus supply or brake.
- 6kV transient protection increased robustness for 380-480V system voltages

There are many other factors that must be considered for optimal performance in any given application. The block diagram below highlights the primary installation considerations. Consult *Wiring and Grounding Guidelines for AC Drives* (publication *DRIVES-IN001*) available on-line at www.rockwellautomation.com/literature, for detailed recommendations on input power conditioning, dynamic braking, reflected wave protection, motor cables types.

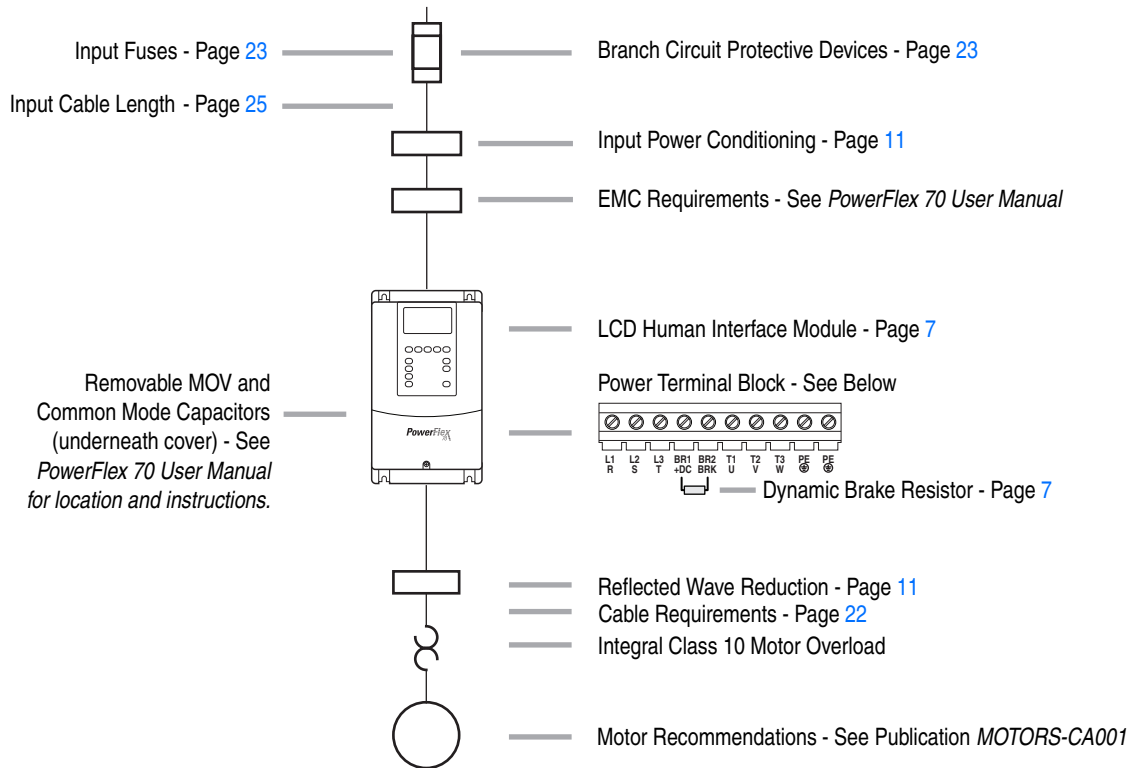

Terminal Blocks

Terminal Block Specifications

No.	Name	Description	Frame	Wire Size Range ⁽¹⁾		Torque	
				Maximum	Minimum	Maximum	Recommended
①	I/O Terminal Block	Signal and control connections	All	1.5 mm ² (16 AWG)	0.05 mm ² (30 AWG)	0.55 N-m (4.9 lb.-in.)	0.5 N-m (4.4 lb.-in.)
②	Power Terminal Block	Input power and motor connections	A, B, & C	3.5 mm ² (12 AWG)	0.3 mm ² (22 AWG)	0.66 N-m (5.5 lb.-in.)	0.6 N-m (5 lb.-in.)
			D	8.4 mm ² (8 AWG)	0.8 mm ² (18 AWG)	1.7 N-m (15 lb.-in.)	1.4 N-m (12 lb.-in.)
			E	25.0 mm ² (3 AWG)	2.5 mm ² (14 AWG)	2.71 N-m (24 lb.-in.)	2.71 N-m (24 lb.-in.)
③	SHLD terminal	Terminating point for wiring shields	All	—	—	1.6 N-m (14 lb.-in.)	1.6 N-m (14 lb.-in.)

(1) Maximum/minimum sizes that the terminal block will accept - these are not recommendations.

Terminal	Description	Notes
BR1	DC Brake (+)	DB Resistor Connection - Important: Do not connect both an internal and external DB resistor at the same time. This may violate the minimum allowed DB resistance and cause drive damage.
BR2	DC Brake (-)	
+DC	DC Bus (+)	④ Test point on Frames A-D located to the left or right of the Power Terminal Block. Frame E has a dedicated terminal.
-DC	DC Bus (-)	
PE	PE Ground	
U, V, W	U (T1), V (T2), W (T3)	To Motor
R, S, T	R (L1), S (L2), T (L3)	AC Line Input Power

Typical Terminal Block Location

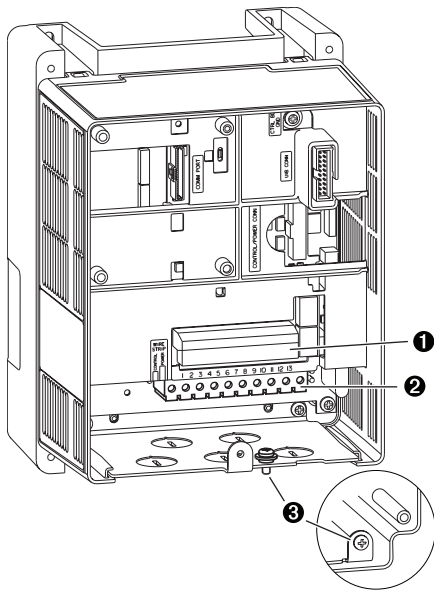

Power Terminals

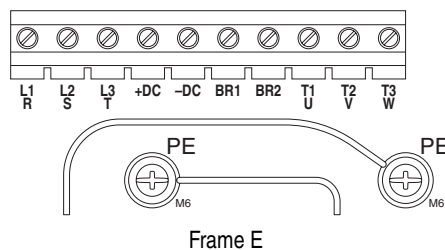
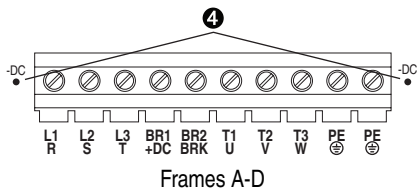

Control Terminals

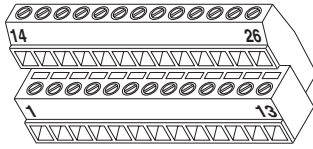

No.	Signal	Factory Default	Description	Related Param.
1	Digital In 1	Stop – CF (CF = Clear Fault)	11.2 mA @ 24V DC 19.2V minimum on state	361 - 366
2	Digital In 2	Start	3.2V maximum off state	
3	Digital In 3	Auto/Man	Important: Use only 24V DC, not suitable for 115V AC circuitry. ⁽³⁾ Inputs can be wired as sink or source.	
4	Digital In 4	Speed Sel 1		
5	Digital In 5	Speed Sel 2		
6	Digital In 6	Speed Sel 3		
7	24V Common	–	Drive supplied power for Digital In1-6 inputs only.	
8	Digital In Common	–	Not intended for use on circuits outside of the drive.	
9	+24V DC	–	See examples beginning on page 20 . 150mA maximum load.	
10	+10V Pot Reference	–	2 k ohm minimum load.	
11	Digital Out 1 – N.O. ⁽¹⁾	NOT Fault	<u>Max Resistive Load</u> 250V AC / 30V DC 50 VA / 60 Watts	380 - 387
12	Digital Out 1 Common		<u>Max Inductive Load</u> 250V AC / 30V DC 25 VA / 30 Watts	
13	Digital Out 1 – N.C. ⁽¹⁾	Fault	<u>Minimum DC Load</u> 10 µA, 10 mV DC	
14	Analog In 1 (– Volts)	⁽²⁾	Non-isolated, 0 to +10V, 10 bit, 100k ohm input impedance. ⁽⁴⁾	320 - 327
15	Analog In 1 (+ Volts)	Voltage – Reads value at 14 & 15		
16	Analog In 1 (– Current)		Non-isolated, 4-20mA, 10 bit, 100 ohm input impedance. ⁽⁴⁾	
17	Analog In 1 (+ Current)			
18	Analog In 2 (– Volts)	⁽²⁾	Isolated, bipolar, differential, 0 to +10V unipolar (10 bit) or ±10V bipolar (10 bit & sign), 100k ohm input impedance. ⁽⁵⁾	340 - 344
19	Analog In 2 (+ Volts)	Voltage – Reads value at 18 & 19		
20	Analog In 2 (– Current)		Isolated, 4-20mA, 10 bit & sign, 100 ohm input impedance. ⁽⁵⁾	
21	Analog In 2 (+ Current)			
22	10V Pot Common Analog Out (– Volts) Analog Out (– Current)	⁽²⁾ Output Freq	0 to +10V, 10 bit, 10k ohm (2k ohm minimum) load. 0 to 20mA, 10 bit, 400 ohm maximum load. ⁽⁶⁾ Referenced to chassis ground.	380 - 387
23	Analog Out (+ Volts) Analog Out (+ Current)		Common if internal 10V supply (terminal 10) is used.	
24	Digital Out 2 – N.O. ⁽¹⁾	Run	See description at No.s 11-13.	380 - 387
25	Digital Out 2 Common			
26	Digital Out 2 – N.C. ⁽¹⁾	NOT Run		

- (1) Contacts shown in unpowered state. Any relay programmed as Fault or Alarm will energize (pick up) when power is applied to drive and deenergize (drop out) when fault or alarm exists. Relays selected for other functions will energize only when that condition exists and will deenergize when condition is removed.
- (2) These inputs/outputs are dependent on a number of parameters. See “Related Parameters.”
- (3) For use with 115V AC circuitry. A 115V AC interface option (AK-M9-115VAC-1) must be used
- (4) Differential Isolation - External source must be less than 10V with respect to PE.
- (5) Differential Isolation - External source must be maintained at less than 160V with respect to PE. Input provides high common mode immunity.
- (6) Analog output current is only available with Enhanced Control drives.

Hardware Enable Circuitry (Enhanced Control Only)

By default, the user can program a digital input as an Enable input. The status of this input is *interpreted by drive software*. If the application requires the drive to be disabled *without* software interpretation, a hardware enable configuration can be utilized. This is done by removing the enable jumper (ENBL JMP) and wiring the enable input to “Digital In 6”.

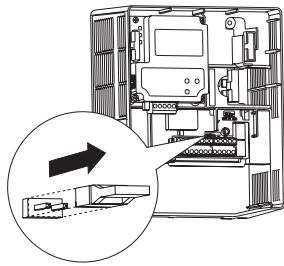

1. Remove drive cover.
2. Locate and remove the “Enable Jumper on the Main Control Board.
3. Wire Enable to “Digital In 6.”
4. Verify that 366 [Digital In6 Sel] is set to option 1 “Enable.”

Safe Off Board Terminal Block (Enhanced Control Only)

No.	Signal	Description
1	Monitor - N.C.	Normally closed contacts for monitoring relay status.
2	Common - N.C.	Maximum Resistive Load: 250V ac / 30V dc / 50 VA / 60 Watts Maximum Inductive Load: 250V ac / 30V dc / 25 VA / 30 Watts
3	+24V dc	Connections for user supplied power to energize coil.
4	24V Common	

Connection Examples

For detailed connection examples refer to the DriveGuard™ Safe-Off Option (Series B) for PowerFlex® 40P and PowerFlex® 70 AC Drives *User Manual*, publication PFLEX-UM003.

Encoder Interface Terminal Block (Enhanced Control Only)

No.	Signal	Description	Jumper Settings
1	5-12V Power ⁽¹⁾	Internal power source 250 mA (isolated)	
2	Power Return		
3	Encoder B (NOT)	Single channel or quadrature B input.	
4	Encoder B		
5	Encoder A (NOT)	Single channel or quadrature A input.	
6	Encoder A		

(1) Jumper selectable +5/12V is available on 20A-ENC-1 Encoder Boards.

Sample Encoder Wiring

I/O	Connection Example	I/O	Connection Example
Encoder Power – Internal Drive Power Internal (drive) 12V DC, 250mA		Encoder Power – External Power Source	
Encoder Signal – Single-Ended, Dual Channel		Encoder Signal – Differential, Dual Channel	

EMC Filters

Description	Frame	Catalog Number	
		User Installed	Factory Installed (Position 13)
External 1-Phase 200-240V, 8A Filter	A	20A-RF-08-A1	N/A
External 3-Phase 200-480V, 5A Filter	A	20A-RF-05-A3	N/A
Internal 3-Phase 200-480 Filter ❶	B, C, D	–	A

❶ Standard on Frames C and D. Optional on Frame B (Frame A ratings increase to Frame B).

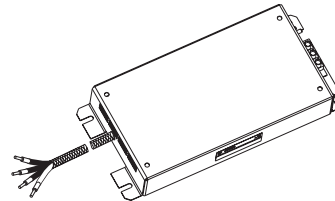

EMC Filter
20A-RF-08-A1
20A-RF-05-A3

Other Options

Description	Catalog No.	Factory Installed	
		User Installed	(Position 15) (Position 16)
Service Connection Board ❷	SK-M9-SCB1	N/A	N/A
115 Volt AC Interface Card	AK-M9-115VAC-1	N/A	N/A
Frame E Flange Gasket	AK-M9-GASKET1-E4	N/A	N/A

❷ Provides temporary DPI/HIM connection for NEMA 1 and Flange drives with cover removed.

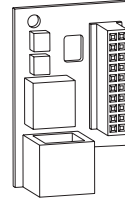

Service Connection Board
SK-M9-SCB1

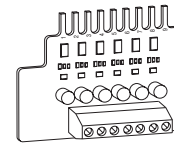

115V Interface Card
AK-M9-115VAC-1

I/O Wiring Examples

Input/Output	Connection Example	Required Parameter Settings
Potentiometer Unipolar Speed Reference 10k Ohm Pot. Recommended (2k Ohm minimum)		Select Speed Reference source: Param. 090 = 1 "Analog In 1" Adjust Scaling: Param. 091, 092, 322, 323 Check Results: Param. 016
Joystick Bipolar Speed Reference ±10V Input		Set Direction Mode: Param. 190 = 1 "Bipolar" Adjust Scaling: Param. 091, 092, 325, 326 Check Results: Param. 017
Analog Input Bipolar Speed Reference ±10V Input		Adjust Scaling: Param. 091, 092, 325, 326 Check Results: Param. 017
Analog Input Unipolar Speed Reference 0 to +10V Input		Adjust Scaling: Param. 091, 092, 325, 326 Check Results: Param. 017
Analog Input, PTC PTC OT set > 5V PTC OT cleared < 4V PTC Short < 0.2V		Set Fault Config 1: Param. 238, Bit #7 = 1 "Enabled" Set Alarm Config 1: Param. 259, Bit #11 = 1 "Enabled"

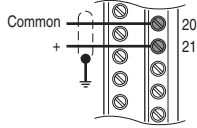
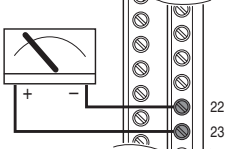
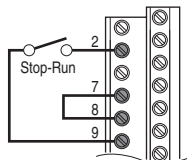
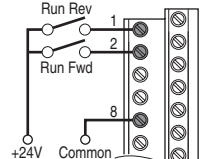
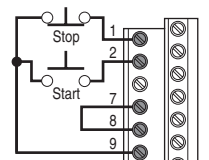
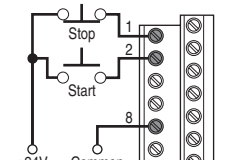
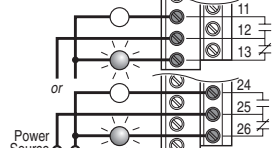
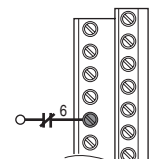
Input/Output	Connection Example	Required Parameter Settings
Analog Input Unipolar Speed Reference 4-20 mA Input		Configure Input for Current: Param. 320, Bit #1 = 1 "Current" Adjust Scaling: Param. 091, 092, 325, 326 Check Results: Param. 017
Analog Output Unipolar 0 to +10V Output. Can Drive a 2k Ohm load (25 mA short circuit limit)		Select Source Value: Param. 342 Adjust Scaling: Param. 343, 344
2 Wire Control Non-Reversing	Internal Supply 	Disable Digital Input 1: Param. 361 = 0 "Not Used" Set Digital Input 2: Param. 362 = 7 "Run"
2 Wire Control Reversing	External Supply 	Set Digital Input 1: Param. 361 = 8 "Run Forward" Set Digital Input 2: Param. 362 = 9 "Run Reverse"
3 Wire Control	Internal Supply 	Use factory default parameter settings.
3 Wire Control	External Supply 	Use factory default parameter settings.
Digital Output Form C Relays Energized in Normal State.		Select Source: Param. 380, 384
Enable Input Shown in enabled state.		Standard Control Configure with parameter 366 Enhanced Control Configure with parameter 366 For dedicated hardware Enable: Remove Enable Jumper (ENBL JMP) located on the Main Control Board.

Cable Recommendations

Cable Types Acceptable for 200-600 Volt Installations

A variety of cable types are acceptable for drive installations. For many installations, unshielded cable is adequate, provided it can be separated from sensitive circuits. As an approximate guide, allow a spacing of 0.3 meters (1 foot) for every 10 meters (32.8 feet) of length. In all cases, long parallel runs must be avoided. Do not use cable with an insulation thickness less than or equal to 15 mils (0.4mm/0.015 in.). Use Copper wire only. Wire gauge requirements and recommendations are based on 75° C. Do not reduce wire gauge when using higher temperature wire. See table below.

Unshielded

THHN, THWN or similar wire is acceptable for drive installation in dry environments provided adequate free air space and/or conduit fill rates limits are provided. **Do not use THHN or similarly coated wire in wet areas.** Any wire chosen must have a minimum insulation thickness of 15 Mils and should not have large variations in insulation concentricity.

Shielded/Armored Cable

Shielded cable contains all of the general benefits of multi-conductor cable with the added benefit of a copper braided shield that can contain much of the noise generated by a typical AC drive. Strong consideration for shielded cable should be given in installations with sensitive equipment such as weigh scales, capacitive proximity switches and other devices that may be affected by electrical noise in the distribution system. Applications with large numbers of drives in a similar location, imposed EMC regulations or a high degree of communications/ networking are also good candidates for shielded cable.

Shielded cable may also help reduce shaft voltage and induced bearing currents for some applications. In addition, the increased impedance of shielded cable may help extend the distance that the motor can be located from the drive without the addition of motor protective devices such as terminator networks. Refer to *Reflected Wave* in “Wiring and Grounding Guidelines for PWM AC Drives,” publication DRIVES-IN001.

Consideration should be given to all of the general specifications dictated by the environment of the installation, including temperature, flexibility, moisture characteristics and chemical resistance. In addition, a braided shield should be included and be specified by the cable manufacturer as having coverage of at least 75%. An additional foil shield can greatly improve noise containment.

A good example of recommended cable is Belden® 295xx (xx determines gauge). This cable has four (4) XLPE insulated conductors with a 100% coverage foil and an 85% coverage copper braided shield (with drain wire) surrounded by a PVC jacket.

Other types of shielded cable are available, but the selection of these types may limit the allowable cable length. Particularly, some of the newer cables bundle 4 conductors of THHN wire and wrap them tightly with a foil shield. This construction can greatly increase the cable charging current required and reduce the overall drive performance. Unless specified in the individual distance tables as tested with the drive, these cables are not recommended and their performance against the lead length limits supplied is not known.

Location	Rating/Type	Description
Standard (Option 1)	600V, 90° C (194° F) XHHW2/RHW-2 Anixter B209500-B209507, Belden 29501-29507, or equivalent	<ul style="list-style-type: none"> Four tinned copper conductors with XLP insulation. Copper braid/aluminum foil combination shield and tinned copper drain wire. PVC jacket.
Standard (Option 2)	Tray rated 600V, 90° C (194° F) RHH/RHW-2 Anixter OLF-7xxxx or equivalent	<ul style="list-style-type: none"> Three tinned copper conductors with XLPE insulation. 5 mil single helical copper tape (25% overlap min.) with three bare copper grounds in contact with shield. PVC jacket.
Class I & II; Division I & II	Tray rated 600V, 90° C (194° F) RHH/RHW-2 Anixter 7V-7xxxx-3G or equivalent	<ul style="list-style-type: none"> Three bare copper conductors with XLPE insulation and impervious corrugated continuously welded aluminum armor. Black sunlight resistant PVC jacket overall. Three copper grounds on #10 AWG and smaller.

Single-Phase Input Power

The PowerFlex 70 drive is typically used with a three-phase input supply. Single-phase operation of the drive is not currently rated under the UL 508C listing. Rockwell Automation has verified that single-phase operation with output current derated by 50% of the three-phase ratings identified in the tables in the Power Ratings and Branch Circuit Protection below.

Power Ratings and Branch Circuit Protection

208 Volt AC Input Protection Devices (See page 24 for Notes)

Drive Catalog Number	Frame ⁽¹⁾	HP Rating		Input Ratings		Output Amps			Dual Element Time Delay Fuse		Non-Time Delay Fuse		Circuit Breaker ⁽⁴⁾	Motor Circuit Protector ⁽⁶⁾	140M Motor Protector with Adjustable Current Range ^{(7) (8)}			
		ND	HD	Amps	kVA	Cont.	1 Min.	3 Sec.	Min. ⁽²⁾	Max. ⁽³⁾	Min. ⁽²⁾	Max. ⁽³⁾			Max. ⁽⁵⁾	Max. ⁽⁵⁾	Available Catalog Numbers ⁽⁹⁾	
208 Volt AC Input																		
20AB2P2	A	0.5	0.33	2.9	1.1	2.5	2.7	3.7	6	6	6	10	15	7	140M-C2E-B40	140M-D8E-B40	-	-
20AB4P2	A	1	0.75	5.6	2	4.8	5.5	7.4	10	10	10	17.5	15	7	140M-C2E-B63	140M-D8E-B63	-	-
20AB6P8	B	2	1.5	10	3.6	7.8	10.3	13.8	15	15	15	30	30	15	140M-C2E-C10	140M-D8E-C10	140M-F8E-C10	-
20AB9P6	B	3	2	14	5.1	11	12.1	16.5	20	25	20	40	40	30	140M-C2E-C16	140M-D8E-C16	140M-F8E-C16	-
20AB015	C	5	3	16	5.8	17.5	19.2	26.6	20	35	20	70	70	30	140M-C2E-C20	140M-D8E-C20	140M-F8E-C20	-
20AB022	D	7.5	5	23.3	8.3	25.3	27.8	37.9	30	50	30	100	100	30	140M-C2E-C25	140M-D8E-C25	140M-F8E-C25	140-CMN-2500
20AB028	D	10	7.5	29.8	10.7	32.2	37.9	50.6	40	70	40	125	125	50	-	-	140M-F8E-C32	140-CMN-4000
20AB042	D	15	10	39.8	14.3	43	55.5	74	60	100	60	175	175	70	-	-	140M-F8E-C45	140-CMN-6300
20AB054	E	20	15	57.5	20.7	62.1	72.4	96.6	80	125	80	200	200	100	-	-	-	140-CMN-6300
20AB070	E	25	20	72.3	26.0	78.2	93.1	124	90	175	90	300	300	100	-	-	-	140-CMN-9000

240 Volt AC Input Protection Devices (See page 24 for Notes)

Drive Catalog Number	Frame ⁽¹⁾	HP Rating		Input Ratings		Output Amps			Dual Element Time Delay Fuse		Non-Time Delay Fuse		Circuit Breaker ⁽⁴⁾	Motor Circuit Protector ⁽⁶⁾	140M Motor Protector with Adjustable Current Range ^{(7) (8)}			
		ND	HD	Amps	kVA	Cont.	1 Min.	3 Sec.	Min. ⁽²⁾	Max. ⁽³⁾	Min. ⁽²⁾	Max. ⁽³⁾			Max. ⁽⁵⁾	Max. ⁽⁵⁾	Available Catalog Numbers ⁽⁹⁾	
240 Volt AC Input																		
20AB2P2	A	0.5	0.33	2.5	1.1	2.2	2.4	3.3	3	4.5	3	8	15	3	140M-C2E-B25	140M-D8E-B25	-	-
20AB4P2	A	1	0.75	4.8	2	4.2	4.8	6.4	6	9	6	15	15	7	140M-C2E-B63	140M-D8E-B63	-	-
20AB6P8	B	2	1.5	8.7	3.6	6.8	9	12	15	15	15	25	25	15	140M-C2E-C10	140M-D8E-C10	140M-F8E-C10	-
20AB9P6	B	3	2	12.2	5.1	9.6	10.6	14.4	20	20	20	35	35	15	140M-C2E-C16	140M-D8E-C16	140M-F8E-C16	-
20AB015	C	5	3	13.9	5.8	15.3	17.4	23.2	20	30	20	60	60	30	140M-C2E-C16	140M-D8E-C16	140M-F8E-C16	-
20AB022	D	7.5	5	19.9	8.3	22	24.4	33	25	45	25	80	80	30	140M-C2E-C25	140M-D8E-C25	140M-F8E-C25	140-CMN-2500
20AB028	D	10	7.5	25.7	10.7	28	33	44	35	60	35	110	110	50	-	-	140M-F8E-C32	140-CMN-4000
20AB042	D	15	10	38.7	16.1	42	46.2	63	50	90	50	150	150	50	-	-	140M-F8E-C45	140-CMN-6300
20AB054	E	20	15	49.8	20.7	54	63	84	60	100	60	200	200	100	-	-	-	140-CMN-6300
20AB070	E	25	20	64.5	26.8	70	81	108	90	150	90	275	275	100	-	-	-	140-CMN-9000

400 Volt AC Input Protection Devices (See page 24 for Notes).

Drive Catalog Number	Frame ⁽¹⁾	kW (400V) HP (480V) Rating		Input Ratings		Output Amps			Dual Element Time Delay Fuse		Non-Time Delay Fuse		Circuit Breaker ⁽⁴⁾	Motor Circuit Protector ⁽⁶⁾	140M Motor Protector with Adjustable Current Range ^{(7) (8)}			
		ND	HD	Amps	kVA	Cont.	1 Min.	3 Sec.	Min. ⁽²⁾	Max. ⁽³⁾	Min. ⁽²⁾	Max. ⁽³⁾			Max. ⁽⁵⁾	Max. ⁽⁵⁾	Available Catalog Numbers ⁽⁹⁾	
400 Volt AC Input																		
20AC1P3	A	0.37	0.25	1.6	1.1	1.3	1.4	1.9	3	3	3	5	15	3	140M-C2E-B16	-	-	-
20AC2P1	A	0.75	0.55	2.5	1.8	2.1	2.4	3.2	4	6	4	8	15	7	140M-C2E-B25	140M-D8E-B25	-	-
20AC3P5	A	1.5	1.1	4.3	3	3.5	4.5	6	6	6	6	12	15	7	140M-C2E-B63	140M-D8E-B63	-	-
20AC5P0	B	2.2	1.5	6.5	4.5	5	5.5	7.5	10	10	10	20	20	15	140M-C2E-C10	140M-D8E-C10	140M-F8E-C10	-
20AC8P7	B	4	3	11.3	7.8	8.7	9.9	13.2	15	17.5	15	30	30	15	140M-C2E-C16	140M-D8E-C16	140M-F8E-C16	-
20AC011	C	5.5	4	11	7.6	11.5	13	17.4	15	25	15	45	40	15	140M-C2E-C16	140M-D8E-C16	140M-F8E-C16	-
20AC015	C	7.5	5.5	15.1	10.4	15.4	17.2	23.1	20	30	20	60	60	20	140M-C2E-C16	140M-D8E-C16	140M-F8E-C16	-
20AC022	D	11	7.5	21.9	15.2	22	24.2	33	30	45	30	80	80	30	140M-C2E-C25	140M-D8E-C25	140M-F8E-C25	140-CMN-2500
20AC030	D	15	11	30.3	21	30	33	45	40	60	40	120	120	50	-	-	140M-F8E-C32	140-CMN-4000
20AC037	D	18.5	15	35	24.3	37	45	60	50	80	50	125	140	50	-	-	140M-F8E-C45	140-CMN-4000

Drive Catalog Number	Frame ⁽¹⁾	kW (400V) HP (480V) Rating		Input Ratings		Output Amps			Dual Element Time Delay Fuse		Non-Time Delay Fuse		Circuit Breaker ⁽⁴⁾	Motor Circuit Protector ⁽⁶⁾	140M Motor Protector with Adjustable Current Range ^{(7) (8)}			
		ND	HD	Amps	kVA	Cont.	1 Min.	3 Sec.	Min. ⁽²⁾	Max. ⁽³⁾	Min. ⁽²⁾	Max. ⁽³⁾	Max. ⁽⁵⁾	Max. ⁽⁵⁾	Available Catalog Numbers ⁽⁹⁾			
20AC043	D	22	18.5	40.7	28.2	43	56	74	60	90	60	150	160	70	-	-	-	140-CMN-6300
20AC060	E	30	22	56.8	39.3	60	66	90	80	125	80	225	240	80	-	-	-	140-CMN-6300
20AC072	E	37	30	68.9	47.8	72	90	120	90	150	90	250	280	100	-	-	-	140-CMN-9000

480 Volt AC Input Protection Devices.

Drive Catalog Number	Frame ⁽¹⁾	kW (400V) HP (480V) Rating		Input Ratings		Output Amps			Dual Element Time Delay Fuse		Non-Time Delay Fuse		Circuit Breaker ⁽⁴⁾	Motor Circuit Protector ⁽⁶⁾	140M Motor Protector with Adjustable Current Range ^{(7) (8)}			
		ND	HD	Amps	kVA	Cont.	1 Min.	3 Sec.	Min. ⁽²⁾	Max. ⁽³⁾	Min. ⁽²⁾	Max. ⁽³⁾	Max. ⁽⁵⁾	Max. ⁽⁵⁾	Available Catalog Numbers ⁽⁹⁾			
480 Volt AC Input																		
20AD1P1	A	0.5	0.33	1.3	1.1	1.1	1.2	1.6	3	3	3	4	15	3	140M-C2E-B16	-	-	-
20AD2P1	A	1	0.75	2.4	2	2.1	2.4	3.2	3	6	3	8	15	3	140M-C2E-B25	140M-D8E-B25	-	-
20AD3P4	A	2	1.5	3.8	3.2	3.4	4.5	6	6	6	6	12	15	7	140M-C2E-B40	140M-D8E-B40	-	-
20AD5P0	B	3	2	5.6	4.7	5	5.5	7.5	10	10	10	20	20	15	140M-C2E-B63	140M-D8E-B63	-	-
20AD8P0	B	5	3	9.8	8.4	8	8.8	12	15	15	15	30	30	15	140M-C2E-C10	140M-D8E-C10	140M-F8E-C10	-
20AD011	C	7.5	5	9.5	7.9	11	12.1	16.5	15	20	15	40	40	15	140M-C2E-C16	140M-D8E-C16	140M-F8E-C16	-
20AD014	C	10	7.5	12.5	10.4	14	16.5	22	20	30	20	50	50	20	140M-C2E-C16	140M-D8E-C16	140M-F8E-C16	-
20AD022	D	15	10	19.9	16.6	22	24.2	33	25	45	25	80	80	30	140M-C2E-C25	140M-D8E-C25	140M-F8E-C25	-
20AD027	D	20	15	24.8	20.6	27	33	44	35	60	35	100	100	50	-	-	140M-F8E-C32	140-CMN-2500
20AD034	D	25	20	31.2	25.9	34	40.5	54	40	70	40	125	125	50	-	-	140M-F8E-C45	140-CMN-4000
20AD040	D	30	25	36.7	39.7	40	51	68	50	90	50	150	150	50	-	-	140M-F8E-C45	140-CMN-4000
20AD052	E	40	30	47.7	39.7	52	60	80	60	110	60	200	200	70	-	-	-	140-CMN-6300
20AD065	E	50	40	59.6	49.6	65	78	104	80	125	80	250	250	100	-	-	-	140-CMN-9000

600 Volt AC Input Protection Devices

Drive Catalog Number	Frame ⁽¹⁾	HP Rating		Input Ratings		Output Amps			Dual Element Time Delay Fuse		Non-Time Delay Fuse		Circuit Breaker ⁽⁴⁾	Motor Circuit Protector ⁽⁶⁾	140M Motor Protector with Adjustable Current Range ^{(7) (8)}			
		ND	HD	Amps	kVA	Cont.	1 Min.	3 Sec.	Min. ⁽²⁾	Max. ⁽³⁾	Min. ⁽²⁾	Max. ⁽³⁾	Max. ⁽⁵⁾	Max. ⁽⁵⁾	Available Catalog Numbers ⁽⁹⁾			
600 Volt AC Input																		
20AE0P9	A	0.5	0.33	1.3	1.3	0.9	1.1	1.4	3	3	3	3.5	15	3	140M-C2E-B16	-	-	-
20AE1P7	A	1	0.75	1.9	2	1.7	2	2.6	3	6	3	6	15	3	140M-C2E-B25	140M-D8E-B25	-	-
20AE2P7	A	2	1.5	3	3.1	2.7	3.6	4.8	4	6	4	10	15	7	140M-C2E-B40	140M-D8E-B40	-	-
20AE3P9	B	3	2	4.4	4.5	3.9	4.3	5.9	6	8	6	15	15	7	140M-C2E-B63	140M-D8E-B63	-	-
20AE6P1	B	5	3	7.5	7.8	6.1	6.7	9.2	10	12	10	20	20	15	140M-C2E-C10	140M-D8E-C10	140M-F8E-C10	-
20AE9P0	C	7.5	5	7.7	8	9	9.9	13.5	10	20	10	35	35	15	140M-C2E-C10	140M-D8E-C10	140M-F8E-C10	-
20AE011	C	10	7.5	9.8	10.1	11	13.5	18	15	20	15	40	40	15	140M-C2E-C16	140M-D8E-C16	140M-F8E-C16	-
20AE017	D	15	10	15.3	15.9	17	18.7	25.5	20	35	20	60	60	30	140M-C2E-C20	140M-D8E-C20	140M-F8E-C20	-
20AE022	D	20	15	20	20.8	22	25.5	34	25	45	25	80	80	30	140M-C2E-C25	140M-D8E-C25	140M-F8E-C25	140-CMN-2500
20AE027	D	25	20	24.8	25.7	27	33	44	35	60	35	100	100	50	-	-	140M-F8E-C25	140-CMN-2500
20AE032	D	30	25	29.4	30.5	32	40.5	54	40	70	40	125	125	50	-	-	140M-F8E-C32	140-CMN-4000
20AE041	E	40	30	37.6	39.1	41	48	64	50	90	50	150	150	100	-	-	140M-F8E-C45	140-CMN-4000
20AE052	E	50	40	47.7	49.6	52	61.5	82	60	110	60	200	200	100	-	-	-	140-CMN-6300

- (1) For IP 66 (NEMA/UL Type 4X/12) enclosures, drives listed as Frame A increase to Frame B and drives listed as Frame C increase to Frame D.
- (2) Minimum protection device size is the lowest rated device that supplies maximum protection without nuisance tripping.
- (3) Maximum protection device size is the highest rated device that supplies drive protection. For US NEC, minimum size is 125% of motor FLA. Ratings shown are maximum.
- (4) Circuit Breaker - inverse time breaker. For US NEC, minimum size is 125% of motor FLA. Ratings shown are maximum.
- (5) Maximum allowable rating by US NEC. Exact size must be chosen for each installation.
- (6) Motor Circuit Protector - instantaneous trip circuit breaker. For US NEC, minimum size is 125% of motor FLA. Ratings shown are maximum.
- (7) Bulletin 140M with adjustable current range should have the current trip set to the minimum range that the device will not trip.
- (8) Manual Self-Protected (Type E) Combination Motor Controller, UL listed for 208 Wye or Delta, 240 Wye or Delta, 480Y/277 or 600Y/347. Not UL listed for use on 480V or 600V Delta/Delta systems in single motor applications.
- (9) The AIC ratings of the Bulletin 140M Motor Protector may vary. See Industrial Controls online catalog at www.ab.com.

Maximum Motor Cable Lengths

In the following tables, a “●” in any of the latter columns will indicate that this drive rating can be used with an Allen-Bradley Terminator (1204-TFA1/1204-TFB2) and/or Reflected Wave Reduction Device with Common Mode Choke (1204-RWC-17) or without choke (1204-RWR2).

- For the Terminator, the maximum cable length is 182.9 meters (600 feet) for 400/480/600V drives. The PWM frequency must be 2 kHz. The 1204-TFA1 can be used only on low HP (5 HP & below), while the 1204-TFB2 can be used from 2-800 HP.
- 1204 Reflected Wave Reduction Device (all motor insulation classes):
 - (1) 1204-RWR2-09
2kHz: 182.9m (600 ft.) at 400/480V and 121.9m (400 ft.) at 600V. 4 kHz: 91.4m (300 ft.) at 400/480V and 61.0m (200 ft.) at 600V.
 - (2) 1204-RWC-17
2 kHz: 365.8m (1200 ft.) at 400/480/600V. 4 kHz: 243.8m (800 ft.) at 400/480V and 121.9m (400 ft.) at 600V.

For both devices, power dissipation in the damping resistor limits maximum cable length.

The 1321-RWR is a complete reflected wave reduction solution available for many of the PowerFlex drives. If available, a 1321-RWR catalog number will be indicated in the “Reactor/RWR” column. When not available, use the reactor and resistor information provided to build a solution.

<i>For Further Information on ...</i>	<i>see Publication ...</i>
1321-RWR	1321-TD001
1204-RWR2	1204-5.1
1204-RWC	1204-IN001
1204-TFxx	1204-IN002

PowerFlex 70 (Standard/Enhanced), 400V Shielded/Unshielded Cable - Meters (Feet)

Drive Frame	Rating		No Solution				Reactor Only				Reactor + Damping Resistor or 1321-RWR				Reactor/RWR	Resistor		Available Options			
	kW	kHz	1000V	1200V	1488V	1600V	1000V	1200V	1488V	1600V	1000V	1200V	1488V	1600V	Cat. No.	Ohms	Watts	TFA1	TFB2	RWR2	RWC
A	0.37	2	7.6 (25)	53.3 (175)	53.3 (175)	53.3 (175)	91.4 (300)	121.9 (400)	121.9 (400)	121.9 (400)	121.9 (400)	121.9 (400)	121.9 (400)	121.9 (400)				●		●	●
		4	7.6 (25)	53.3 (175)	53.3 (175)	53.3 (175)	18.3 (60)	91.4 (300)	121.9 (400)	121.9 (400)	121.9 (400)	121.9 (400)	121.9 (400)	121.9 (400)						●	●
	0.75	2	7.6 (25)	83.8 (275)	83.8 (275)	83.8 (275)	91.4 (300)	152.4 (500)	152.4 (500)	152.4 (500)	152.4 (500)	152.4 (500)	152.4 (500)	152.4 (500)				●		●	●
		4	7.6 (25)	76.2 (250)	76.2 (250)	76.2 (250)	18.3 (60)	91.4 (300)	152.4 (500)	152.4 (500)	152.4 (500)	152.4 (500)	152.4 (500)	152.4 (500)						●	●
	1.5	2	7.6 (25)	83.8 (275)	83.8 (275)	83.8 (275)	91.4 (300)	182.9 (600)	182.9 (600)	182.9 (600)	182.9 (600)	182.9 (600)	182.9 (600)	182.9 (600)				●	●	●	●
		4	7.6 (25)	76.2 (250)	76.2 (250)	76.2 (250)	18.3 (60)	91.4 (300)	182.9 (600)	182.9 (600)	182.9 (600)	182.9 (600)	182.9 (600)	182.9 (600)						●	●
B	2.2	2	7.6 (25)	137.2 (450)	182.9 (600)	182.9 (600)	91.4 (300)	182.9 (600)	182.9 (600)	182.9 (600)	182.9 (600)	182.9 (600)	182.9 (600)	182.9 (600)				●	●	●	●
		4	7.6 (25)	91.4 (300)	152.4 (500)	182.9 (600)	18.3 (60)	91.4 (300)	182.9 (600)	182.9 (600)	182.9 (600)	182.9 (600)	182.9 (600)	182.9 (600)						●	●
	4	2	7.6 (25)	137.2 (450)	243.8 (800)	243.8 (800)	91.4 (300)	243.8 (800)	243.8 (800)	243.8 (800)	243.8 (800)	243.8 (800)	243.8 (800)	243.8 (800)	1321-RWR8-DP				●		●
		4	7.6 (25)	91.4 (300)	152.4 (500)	213.4 (700)	18.3 (60)	91.4 (300)	243.8 (800)	243.8 (800)	243.8 (800)	182.9 (600)	243.8 (800)	243.8 (800)	1321-RWR8-DP						●
C	5.5	2	7.6 (25)	137.2 (450)	304.8 (1000)	304.8 (1000)	91.4 (300)	304.8 (1000)	304.8 (1000)	304.8 (1000)	304.8 (1000)	304.8 (1000)	304.8 (1000)	304.8 (1000)	1321-RWR12-DP				●		●
		4	7.6 (25)	91.4 (300)	152.4 (500)	213.4 (700)	18.3 (60)	91.4 (300)	304.8 (1000)	304.8 (1000)	182.9 (600)	304.8 (1000)	304.8 (1000)	304.8 (1000)	1321-RWR12-DP						●
	7.5	2	7.6 (25)	137.2 (450)	365.8 (1200)	365.8 (1200)	91.4 (300)	365.8 (1200)	365.8 (1200)	365.8 (1200)	365.8 (1200)	365.8 (1200)	365.8 (1200)	365.8 (1200)	1321-RWR18-DP				●		●
		4	7.6 (25)	91.4 (300)	152.4 (500)	213.4 (700)	18.3 (60)	91.4 (300)	365.8 (1200)	365.8 (1200)	182.9 (600)	304.8 (1000)	365.8 (1200)	365.8 (1200)	1321-RWR18-DP						●
D	11	2	7.6 (25)	137.2 (450)	365.8 (1200)	365.8 (1200)	91.4 (300)	365.8 (1200)	365.8 (1200)	365.8 (1200)	365.8 (1200)	365.8 (1200)	365.8 (1200)	365.8 (1200)	1321-RWR25-DP				●		
		4	7.6 (25)	91.4 (300)	152.4 (500)	213.4 (700)	18.3 (60)	91.4 (300)	365.8 (1200)	365.8 (1200)	182.9 (600)	304.8 (1000)	365.8 (1200)	365.8 (1200)	1321-RWR25-DP						
	15	2	7.6 (25)	137.2 (450)	365.8 (1200)	365.8 (1200)	91.4 (300)	365.8 (1200)	365.8 (1200)	365.8 (1200)	365.8 (1200)	365.8 (1200)	365.8 (1200)	365.8 (1200)	1321-RWR35-DP				●		
		4	7.6 (25)	91.4 (300)	152.4 (500)	213.4 (700)	18.3 (60)	91.4 (300)	365.8 (1200)	365.8 (1200)	182.9 (600)	304.8 (1000)	365.8 (1200)	365.8 (1200)	1321-RWR35-DP						
D	18.5	2	7.6 (25)	137.2 (450)	365.8 (1200)	365.8 (1200)	91.4 (300)	365.8 (1200)	365.8 (1200)	365.8 (1200)	365.8 (1200)	365.8 (1200)	365.8 (1200)	365.8 (1200)	1321-RWR35-DP				●		
		4	7.6 (25)	91.4 (300)	152.4 (500)	213.4 (700)	18.3 (60)	91.4 (300)	365.8 (1200)	365.8 (1200)	182.9 (600)	304.8 (1000)	365.8 (1200)	365.8 (1200)	1321-RWR35-DP						
D	22	2	7.6 (25)	137.2 (450)	365.8 (1200)	365.8 (1200)	91.4 (300)	365.8 (1200)	365.8 (1200)	365.8 (1200)	365.8 (1200)	365.8 (1200)	365.8 (1200)	365.8 (1200)	1321-RWR45-DP				●		
		4	7.6 (25)	91.4 (300)	152.4 (500)	213.4 (700)	18.3 (60)	91.4 (300)	365.8 (1200)	365.8 (1200)	182.9 (600)	304.8 (1000)	365.8 (1200)	365.8 (1200)	1321-RWR45-DP						
E	30	2	7.6 (25)	137.2 (450)	304.8 (1000)	365.8 (1200)	91.4 (300)	365.8 (1200)	365.8 (1200)	365.8 (1200)	365.8 (1200)	365.8 (1200)	365.8 (1200)	365.8 (1200)	1321-RWR55-DP				●		
		4	7.6 (25)	91.4 (300)	152.4 (500)	213.4 (700)	18.3 (60)	91.4 (300)	365.8 (1200)	365.8 (1200)	182.9 (600)	304.8 (1000)	365.8 (1200)	365.8 (1200)	1321-RWR55-DP						
	37	2	12.2 (40)	137.2 (450)	304.8 (1000)	365.8 (1200)	91.4 (300)	365.8 (1200)	365.8 (1200)	365.8 (1200)	365.8 (1200)	365.8 (1200)	365.8 (1200)	365.8 (1200)	1321-RWR80-DP				●		
		4	12.2 (40)	91.4 (300)	152.4 (500)	213.4 (700)	18.3 (60)	91.4 (300)	365.8 (1200)	365.8 (1200)	182.9 (600)	304.8 (1000)	365.8 (1200)	365.8 (1200)	1321-RWR80-DP						

PowerFlex 70 (Standard/Enhanced), 480V Shielded/Unshielded Cable - Meters (Feet)

Drive Frame	Rating		No Solution				Reactor Only				Reactor + Damping Resistor or 1321-RWR				Reactor/RWR		Resistor		Available Options			
	HP	kHz	1000V	1200V	1488V	1600V	1000V	1200V	1488V	1600V	1000V	1200V	1488V	1600V	Cat. No.	Ohms	Watts	TFA1	TFB2	RWR2	RWC	
A	0.5	2	7.6 (25)	12.2 (40)	53.3 (175)	53.3 (175)	7.6 (25)	91.4 (300)	121.9 (400)	121.9 (400)	121.9 (400)	121.9 (400)	121.9 (400)	121.9 (400)				●		●	●	
		4	7.6 (25)	12.2 (40)	53.3 (175)	53.3 (175)	7.6 (25)	12.2 (40)	121.9 (400)	121.9 (400)	121.9 (400)	121.9 (400)	121.9 (400)	121.9 (400)						●	●	
	1	2	7.6 (25)	12.2 (40)	83.8 (275)	83.8 (275)	7.6 (25)	91.4 (300)	152.4 (500)	152.4 (500)	152.4 (500)	152.4 (500)	152.4 (500)	152.4 (500)				●		●	●	
		4	7.6 (25)	12.2 (40)	76.2 (250)	76.2 (250)	7.6 (25)	12.2 (40)	121.9 (400)	152.4 (500)	152.4 (500)	152.4 (500)	152.4 (500)	152.4 (500)						●	●	
	2	2	7.6 (25)	12.2 (40)	83.8 (275)	83.8 (275)	7.6 (25)	91.4 (300)	182.9 (600)	182.9 (600)	182.9 (600)	182.9 (600)	182.9 (600)	182.9 (600)				●	●	●	●	
		4	7.6 (25)	12.2 (40)	76.2 (250)	76.2 (250)	7.6 (25)	12.2 (40)	121.9 (400)	182.9 (600)	182.9 (600)	182.9 (600)	182.9 (600)	182.9 (600)						●	●	
B	3	2	7.6 (25)	12.2 (40)	129.5 (425)	129.5 (425)	7.6 (25)	91.4 (300)	182.9 (600)	182.9 (600)	182.9 (600)	182.9 (600)	182.9 (600)	182.9 (600)				●	●	●	●	
		4	7.6 (25)	12.2 (40)	121.9 (400)	121.9 (400)	7.6 (25)	12.2 (40)	121.9 (400)	182.9 (600)	182.9 (600)	182.9 (600)	182.9 (600)	182.9 (600)						●	●	
	5	2	7.6 (25)	12.2 (40)	137.2 (450)	182.9 (600)	7.6 (25)	91.4 (300)	243.8 (800)	243.8 (800)	182.9 (600)	243.8 (800)	243.8 (800)	243.8 (800)	1321-RWR8-DP			●	●	●	●	
		4	7.6 (25)	12.2 (40)	121.9 (400)	182.9 (600)	7.6 (25)	12.2 (40)	121.9 (400)	243.8 (800)	182.9 (600)	243.8 (800)	243.8 (800)	243.8 (800)	1321-RWR8-DP					●	●	
C	7.5	2	7.6 (25)	12.2 (40)	137.2 (450)	182.9 (600)	7.6 (25)	91.4 (300)	304.8 (1000)	304.8 (1000)	182.9 (600)	304.8 (1000)	304.8 (1000)	304.8 (1000)	1321-RWR12-DP				●		●	
		4	7.6 (25)	12.2 (40)	121.9 (400)	182.9 (600)	7.6 (25)	12.2 (40)	121.9 (400)	304.8 (1000)	182.9 (600)	304.8 (1000)	304.8 (1000)	304.8 (1000)	1321-RWR12-DP						●	
	10	2	7.6 (25)	12.2 (40)	137.2 (450)	182.9 (600)	7.6 (25)	91.4 (300)	365.8 (1200)	365.8 (1200)	182.9 (600)	365.8 (1200)	365.8 (1200)	365.8 (1200)	1321-RWR18-DP				●		●	
		4	7.6 (25)	12.2 (40)	121.9 (400)	182.9 (600)	7.6 (25)	12.2 (40)	121.9 (400)	304.8 (1000)	182.9 (600)	304.8 (1000)	365.8 (1200)	365.8 (1200)	1321-RWR18-DP						●	
D	15	2	7.6 (25)	12.2 (40)	137.2 (450)	182.9 (600)	7.6 (25)	91.4 (300)	365.8 (1200)	365.8 (1200)	182.9 (600)	365.8 (1200)	365.8 (1200)	365.8 (1200)	1321-RWR25-DP				●			
		4	7.6 (25)	12.2 (40)	121.9 (400)	182.9 (600)	7.6 (25)	12.2 (40)	121.9 (400)	304.8 (1000)	182.9 (600)	304.8 (1000)	365.8 (1200)	365.8 (1200)	1321-RWR25-DP							
	20	2	7.6 (25)	12.2 (40)	137.2 (450)	182.9 (600)	7.6 (25)	91.4 (300)	365.8 (1200)	365.8 (1200)	182.9 (600)	365.8 (1200)	365.8 (1200)	365.8 (1200)	1321-RWR35-DP				●			
		4	7.6 (25)	12.2 (40)	121.9 (400)	182.9 (600)	7.6 (25)	12.2 (40)	121.9 (400)	304.8 (1000)	182.9 (600)	304.8 (1000)	365.8 (1200)	365.8 (1200)	1321-RWR35-DP							
	25	2	7.6 (25)	12.2 (40)	137.2 (450)	182.9 (600)	7.6 (25)	76.2 (250)	365.8 (1200)	365.8 (1200)	182.9 (600)	365.8 (1200)	365.8 (1200)	365.8 (1200)	1321-RWR35-DP				●			
		4	7.6 (25)	12.2 (40)	121.9 (400)	182.9 (600)	7.6 (25)	12.2 (40)	121.9 (400)	274.3 (900)	152.4 (500)	304.8 (1000)	365.8 (1200)	365.8 (1200)	1321-RWR35-DP							
	30	2	7.6 (25)	12.2 (40)	137.2 (450)	182.9 (600)	7.6 (25)	76.2 (250)	365.8 (1200)	365.8 (1200)	182.9 (600)	365.8 (1200)	365.8 (1200)	365.8 (1200)	1321-RWR45-DP				●			
		4	7.6 (25)	12.2 (40)	121.9 (400)	182.9 (600)	7.6 (25)	12.2 (40)	121.9 (400)	243.8 (800)	152.4 (500)	304.8 (1000)	365.8 (1200)	365.8 (1200)	1321-RWR45-DP							
E	40	2	7.6 (25)	12.2 (40)	137.2 (450)	182.9 (600)	7.6 (25)	76.2 (250)	365.8 (1200)	365.8 (1200)	152.4 (500)	365.8 (1200)	365.8 (1200)	365.8 (1200)	1321-RWR55-DP				●			
		4	7.6 (25)	12.2 (40)	106.7 (350)	152.4 (500)	7.6 (25)	12.2 (40)	106.7 (350)	228.6 (750)	121.9 (400)	243.8 (800)	365.8 (1200)	365.8 (1200)	1321-RWR55-DP							
	50	2	12.2 (40)	18.3 (60)	137.2 (450)	182.9 (600)	12.2 (40)	61.0 (200)	304.8 (1000)	365.8 (1200)	152.4 (500)	365.8 (1200)	365.8 (1200)	365.8 (1200)	1321-RWR80-DP				●			
		4	7.6 (25)	12.2 (40)	91.4 (300)	152.4 (500)	12.2 (40)	18.3 (60)	106.7 (350)	228.6 (750)	91.4 (300)	243.8 (800)	365.8 (1200)	365.8 (1200)	1321-RWR80-DP							

PowerFlex 70 Technical Data

PowerFlex 70 (Standard/Enhanced), 600V Shielded/Unshielded Cable - Meters (Feet)

Drive Frame	Rating		No Solution		Reactor Only		1321-RWR		RWR	Available Options			
	HP	kHz	1488V	1850V	1488V	1850V	1488V	1850V	Cat. No.	TFA1	TFB2	RWR2	RWC
A	1	2	42.7 (140)	121.9 (400)	121.9 (400)	121.9 (400)	121.9 (400)	121.9 (400)		●		●	●
		4	30.5 (100)	121.9 (400)	30.5 (100)	121.9 (400)	121.9 (400)	121.9 (400)				●	●
	2	2	42.7 (140)	152.4 (500)	152.4 (500)	152.4 (500)	152.4 (500)	152.4 (500)		●		●	●
		4	30.5 (100)	137.2 (450)	30.5 (100)	152.4 (500)	152.4 (500)	152.4 (500)				●	●
B	3	2	42.7 (140)	152.4 (500)	152.4 (500)	182.9 (600)	182.9 (600)	182.9 (600)		●		●	●
		4	30.5 (100)	137.2 (450)	30.5 (100)	152.4 (500)	182.9 (600)	182.9 (600)				●	●
	5	2	42.7 (140)	152.4 (500)	152.4 (500)	243.8 (800)	243.8 (800)	243.8 (800)	1321-RWR8-EP	●		●	●
		4	30.5 (100)	137.2 (450)	30.5 (100)	152.4 (500)	243.8 (800)	243.8 (800)	1321-RWR8-EP			●	●
C	7.5	2	42.7 (140)	152.4 (500)	152.4 (500)	304.8 (1000)	304.8 (1000)	304.8 (1000)	1321-RWR12-EP				●
		4	30.5 (100)	137.2 (450)	30.5 (100)	152.4 (500)	304.8 (1000)	304.8 (1000)	1321-RWR12-EP				●
	10	2	42.7 (140)	182.9 (600)	152.4 (500)	365.8 (1200)	365.8 (1200)	365.8 (1200)	1321-RWR12-EP				●
		4	30.5 (100)	137.2 (450)	30.5 (100)	152.4 (500)	304.8 (1000)	365.8 (1200)	1321-RWR12-EP				●
D	15	2	42.7 (140)	182.9 (600)	152.4 (500)	365.8 (1200)	365.8 (1200)	365.8 (1200)	1321-RWR18-EP				
		4	30.5 (100)	137.2 (450)	30.5 (100)	152.4 (500)	304.8 (1000)	365.8 (1200)	1321-RWR18-EP				
	20	2	42.7 (140)	182.9 (600)	152.4 (500)	365.8 (1200)	365.8 (1200)	365.8 (1200)	1321-RWR25-EP		●		
		4	30.5 (100)	137.2 (450)	30.5 (100)	152.4 (500)	304.8 (1000)	365.8 (1200)	1321-RWR25-EP				
	25	2	42.7 (140)	182.9 (600)	152.4 (500)	365.8 (1200)	365.8 (1200)	365.8 (1200)	1321-RWR35-EP		●		
		4	30.5 (100)	137.2 (450)	30.5 (100)	152.4 (500)	304.8 (1000)	365.8 (1200)	1321-RWR35-EP				
30	2	42.7 (140)	182.9 (600)	152.4 (500)	365.8 (1200)	365.8 (1200)	365.8 (1200)	1321-RWR35-EP		●			
	4	30.5 (100)	137.2 (450)	36.6 (120)	152.4 (500)	304.8 (1000)	365.8 (1200)	1321-RWR35-EP					
E	40	2	42.7 (140)	182.9 (600)	152.4 (500)	365.8 (1200)	365.8 (1200)	365.8 (1200)	1321-RWR45-EP		●		
		4	30.5 (100)	137.2 (450)	36.6 (120)	152.4 (500)	304.8 (1000)	365.8 (1200)	1321-RWR45-EP				
	50	2	42.7 (140)	182.9 (600)	152.4 (500)	365.8 (1200)	365.8 (1200)	365.8 (1200)	1321-RWR55-EP		●		
		4	36.6 (120)	137.2 (450)	45.7 (150)	152.4 (500)	304.8 (1000)	365.8 (1200)	1321-RWR55-EP				

Mounting

Maximum Surrounding Air Temperature

Enclosure Rating	Temperature Range
Open Type, IP 20, NEMA/UL Type 1 & Flange Mount	0 to 50 degrees C (32 to 122 degrees F)
IP 66, NEMA/UL Type 4X/12	0 to 40 degrees C (32 to 104 degrees F)
IP 54, NEMA/UL Type 12	0 to 40 degrees C (32 to 104 degrees F)

Important: Some drives are equipped with an adhesive label on the top of the chassis. Removing the adhesive label from the drive changes the enclosure rating from NEMA/UL Type 1 Enclosed to Type Open.

Minimum Mounting Clearances

Specified vertical clearance requirements are intended to be from drive to drive. Other objects can occupy this space; however, reduced airflow may cause protection circuits to fault the drive. In addition, inlet air temperature must not exceed the product specification.

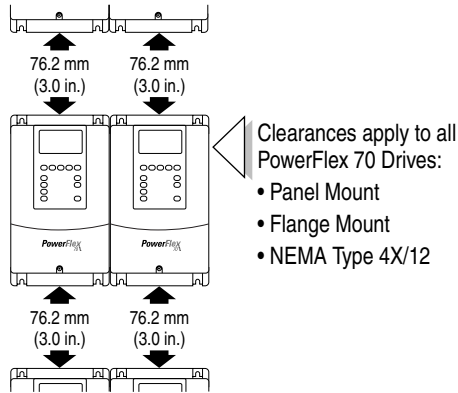

PowerFlex 70 Frames

Output Power		Frame Size							
kW ND (HD)	HP ND (HD)	208-240V AC Input			400-480V AC Input			600V AC Input	
		Not Filtered	Filtered	IP66 (4X/12)	Not Filtered	Filtered	IP66 (4X/12)	Not Filtered	Filtered
0.37 (0.25)	0.5 (0.33)	A	B	B	A	B	B	A	-
0.75 (0.55)	1 (0.75)	A	B	B	A	B	B	A	-
1.5 (1.1)	2 (1.5)	B	B	B	A	B	B	A	-
2.2 (1.5)	3 (2)	B	B	B	B	B	B	B	-
4 (3)	5 (3)	-	C	D	B	B	B	B	-
5.5 (4)	7.5 (5)	-	D	D	-	C	D	C	-
7.5 (5.5)	10 (7.5)	-	D	D	-	C	D	C	-
11 (7.5)	15 (10)	-	D	D	-	D	D	D	-
15 (11)	20 (15)	-	E	E	-	D	D	D	-
18.5 (15)	25 (20)	-	E	E	-	D	D	-	-
22 (18.5)	30 (25)	-	-	-	-	D	D	-	-
30 (22)	40 (30)	-	-	-	-	E	E	-	-
37 (30)	50 (40)	-	-	-	-	E	E	-	-

Approximate Dimensions

Frames A-E

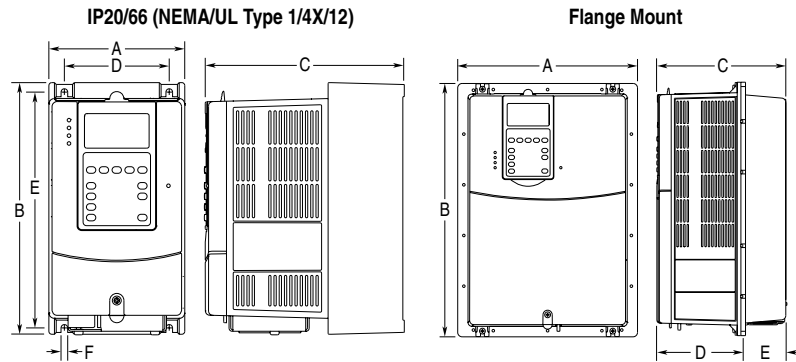

Dimensions are in millimeters and (inches).

Frame	Dimension						Weight ⁽¹⁾ kg (lbs.)
	A	B	C	D	E	F	
IP20, NEMA/UL Type 1							
A	122.4 (4.82)	225.7 (8.89)	179.8 (7.08)	94.2 (3.71)	211.6 (8.33)	5.8 (0.23)	2.71 (6.0)
B	171.7 (6.76)	234.6 (9.24)	179.8 (7.08)	122.7 (4.83)	220.2 (8.67)	5.8 (0.23)	3.60 (7.9)
C	185.0 (7.28)	300.0 (11.81)	179.8 (7.08)	137.6 (5.42)	285.6 (11.25)	5.8 (0.23)	6.89 (15.2)
D	219.9 (8.66)	350.0 (13.78)	179.8 (7.08)	169.0 (6.65)	335.6 (13.21)	5.8 (0.23)	9.25 (20.4)
E	280.3 (11.04)	555.8 (21.88)	207.1 (8.15)	200.0 (7.87)	491.0 (19.33)	6.9 (0.27)	18.60 (41.0)
IP66, NEMA/UL Type 4X/12							
B	171.7 (6.76)	239.8 (9.44)	203.3 (8.00)	122.7 (4.83)	220.2 (8.67)	5.8 (0.23)	3.61 (8.0)
D	219.9 (8.66)	350.0 (13.78)	210.7 (8.29)	169.0 (6.65)	335.6 (13.21)	5.8 (0.23)	9.13 (20.1)
E	280.3 (11.04)	555.8 (21.88)	219.8 (8.65)	200.0 (7.87)	491.0 (19.33)	6.9 (0.27)	18.60 (41.0)
Flange Mount							
A	156.0 (6.14)	225.8 (8.89)	178.6 (7.03)	123.0 (4.84)	55.6 (2.19)	–	2.71 (6.0)
B	205.2 (8.08)	234.6 (9.24)	178.6 (7.03)	123.0 (4.84)	55.6 (2.19)	–	3.60 (7.9)
C	219.0 (8.62)	300.0 (11.81)	178.6 (7.03)	123.0 (4.84)	55.6 (2.19)	–	6.89 (15.2)
D	248.4 (9.78)	350.0 (13.78)	178.6 (7.03)	123.0 (4.84)	55.6 (2.19)	–	9.25 (20.4)
E	280.3 (11.04)	555.8 (21.88)	207.1 (8.15)	117.2 (4.61)	89.9 (3.54)	–	18.60 (41.0)

(1) Weights include HIM and Standard I/O.

IP20, NEMA/UL Type 1 Bottom View Dimensions

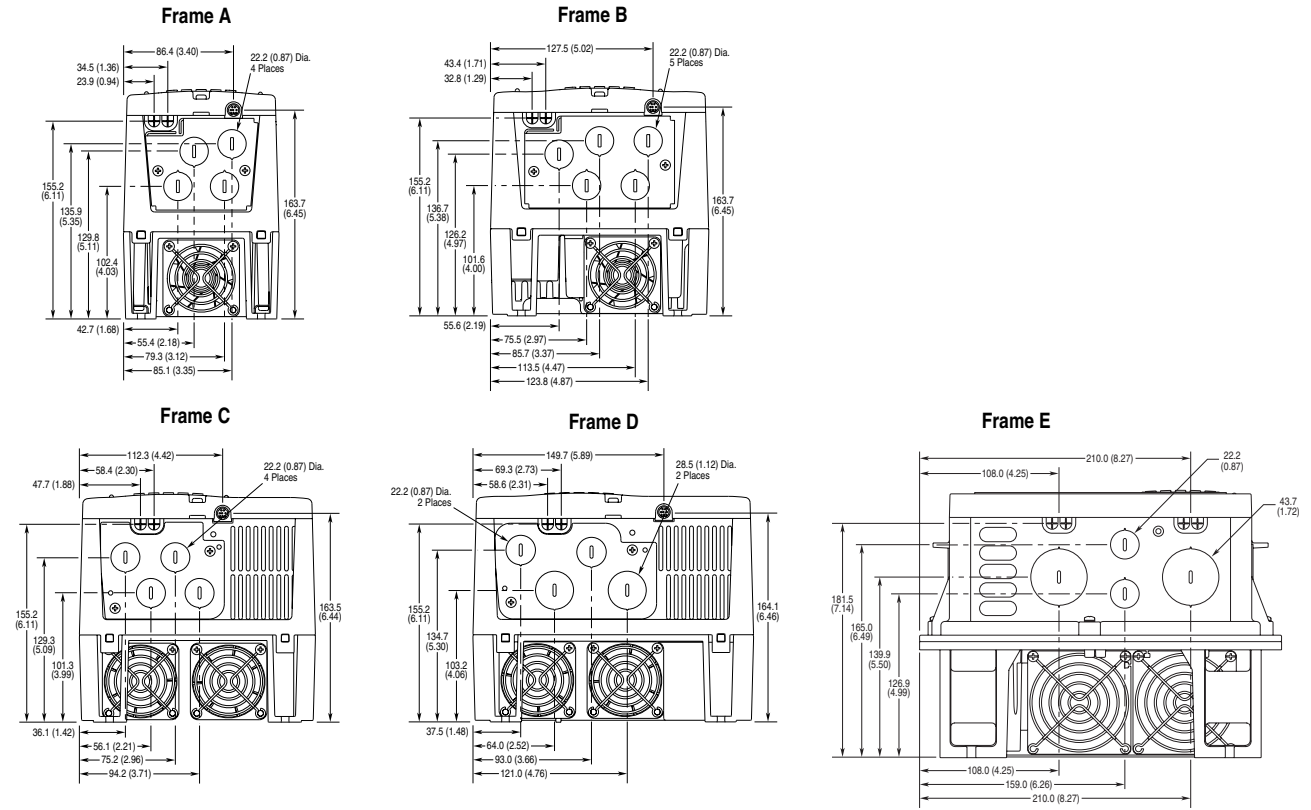

Dimensions are in millimeters and (inches).

IP 66 (NEMA/UL Type 4X/12) Bottom View Dimensions

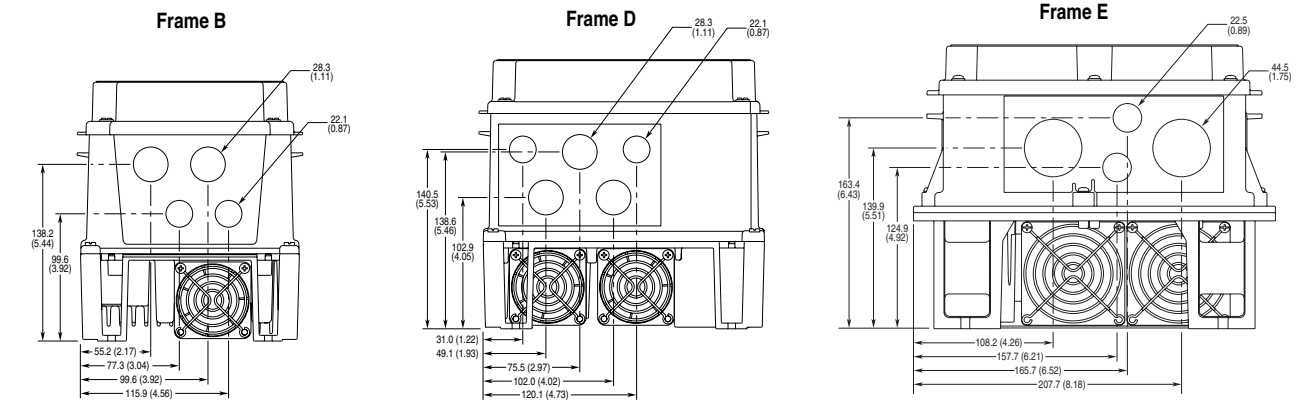

Dimensions are in millimeters and (inches).

Flange Mount Bottom View Dimensions

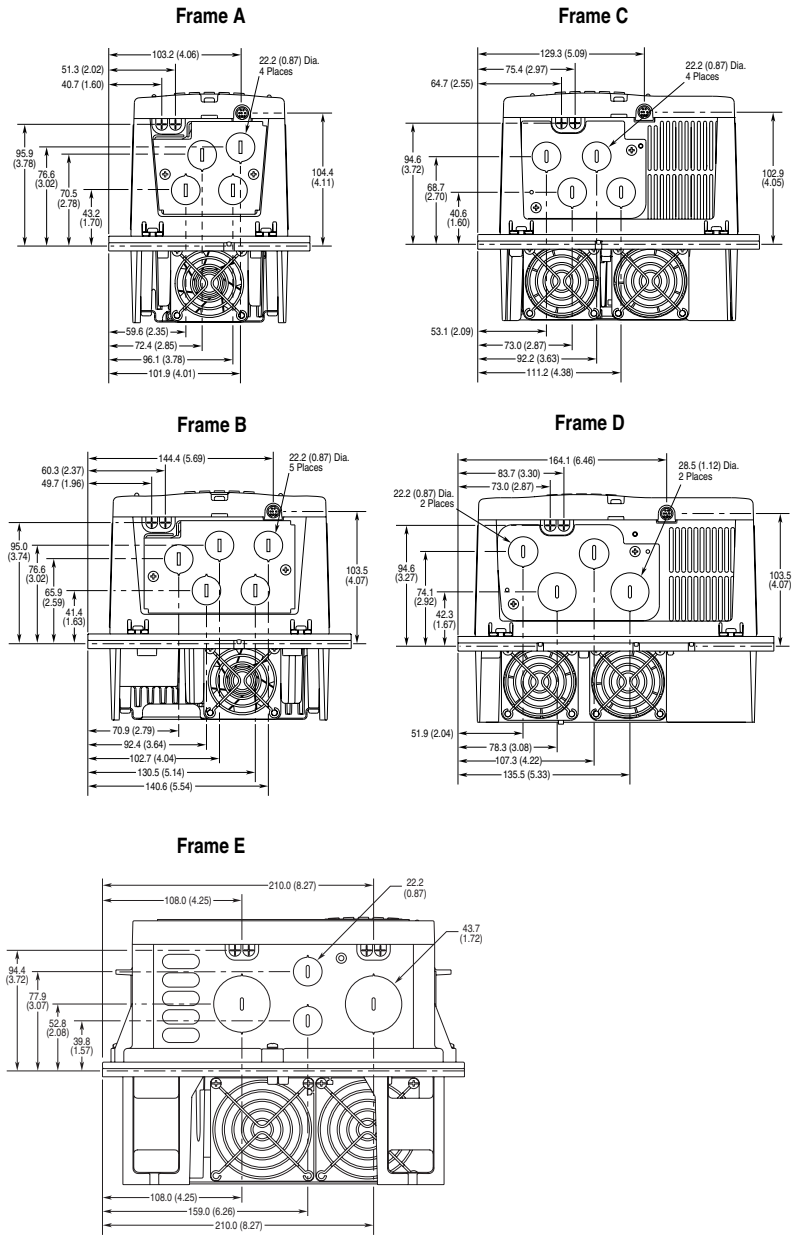

Dimensions are in millimeters and (inches).

Cutout Dimensions

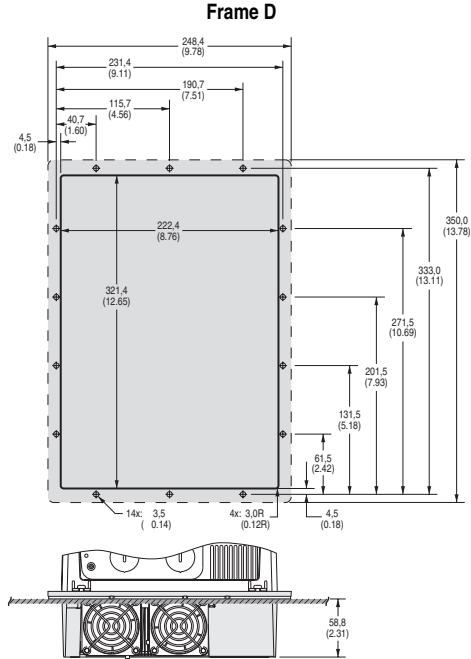
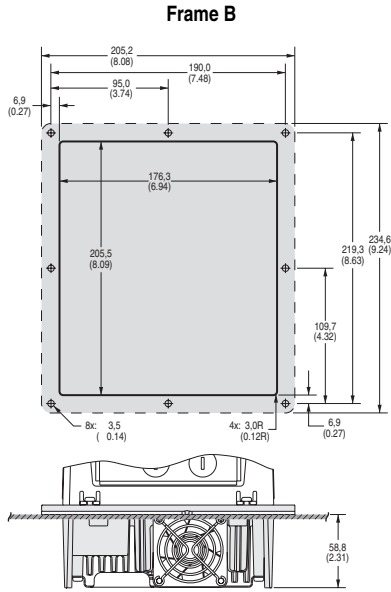
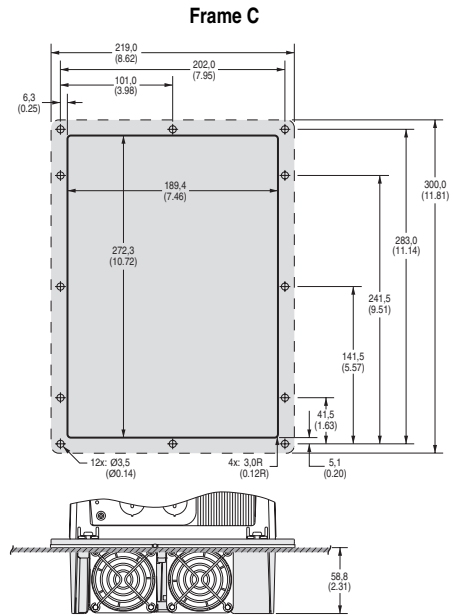
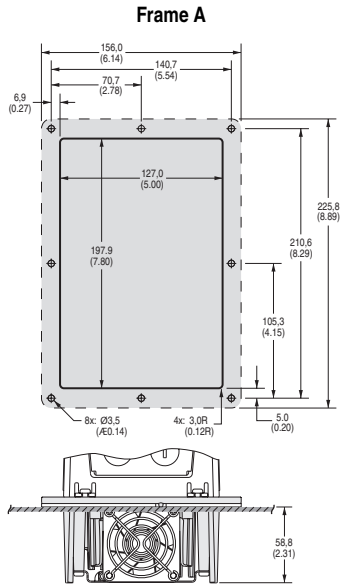

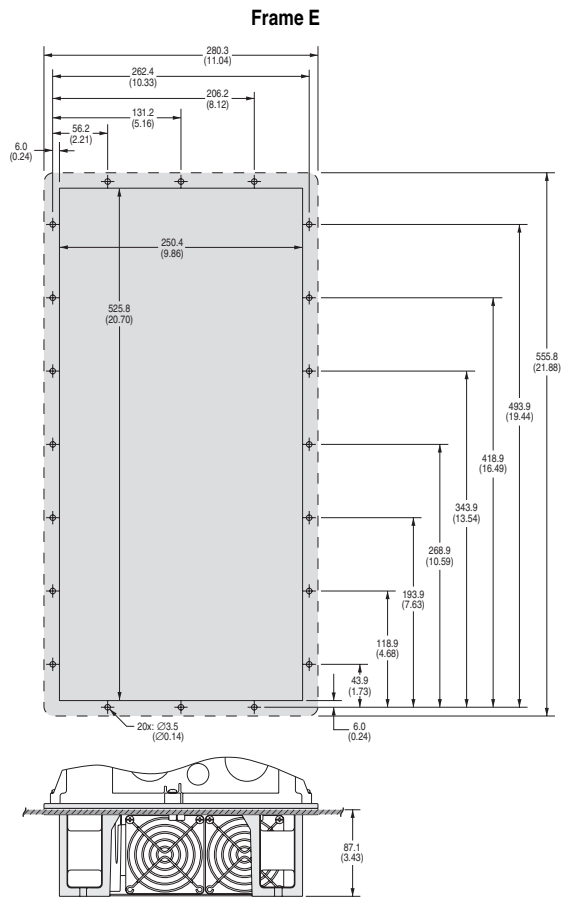

PowerFlex 70 Configured Drives

The PowerFlex 70 Packaged Drives Program allows users to create drive packages based on their specific needs. This program enhances stand-a-lone drive functionality through additional control, power and packaging options which are ideal for OEM and end users with special installation needs.

The program has three levels:

Catalog Configured Drives

The Catalog Configured Drives Program allows users to create drive packages based on their specific needs. A complete drive package may be specified by assembling a single catalog number string that includes a base drive and all required options. Packaging is available for 480V requirements in NEMA Type 1 (IP20), NEMA 4/12 (IP65) indoor, and NEMA 3/4 (IP65) outdoor. The program consists of a fully defined catalog string identified within the price sheet. Focused on higher volume, repeat business, the standard designs provide consistent manufacturing and minimizes customer resources by reducing engineering, manufacturing and installation time. Typical delivery is 10 business days from order entry and can be ordered through the Passport order entry system. *This program uses the Enhanced Control version of the PowerFlex 70.*

Modified Configured Drives

The Modified Configured Drives Program offers users the ability to create drive packages beyond the Catalog Configured Drives offering. Packaging is available for 208V, 240V, 480V and 600V requirements. *This program supports both the Standard and the Enhanced Control versions of the PowerFlex 70.* Options may or may not be defined within this publication. Product can be ordered by:

- Assembling a catalog string from the options listed in this publication.
Configured options that are listed within this publication will be specified by the heading “*Modified Configured Drives Program Only*” and will have varied lead-times.
- Entering a custom quote request for additional options not listed.
A custom quote will require a Passport quote using “SP-SDB-CUSTOM” as the line item part number and entering a description of the base catalog string and custom options in the Competitive Summary. For questions or help with a custom quote please contact the Configured Drives Group at 262-512-8415.

Catalog Configured Drives Program

NEMA Type 1
NEMA Type 4/12 Indoor
NEMA Type 3/4 Outdoor

- Enhanced Control
- Flange Mount Drive
- Welded Construction
- 480V Rating

All Enclosure Types

- Drive Input Protection Options
- Input/Output Contactors
- Bypass Options
- Input/Output Line Reactor Options
- 115V Control Power Options
- Control Interface and Feedback Options
- Human Interface Modules
- Motor Interface Options
- Operator Devices
- Drawing and Test Options



Approximate Dimensions

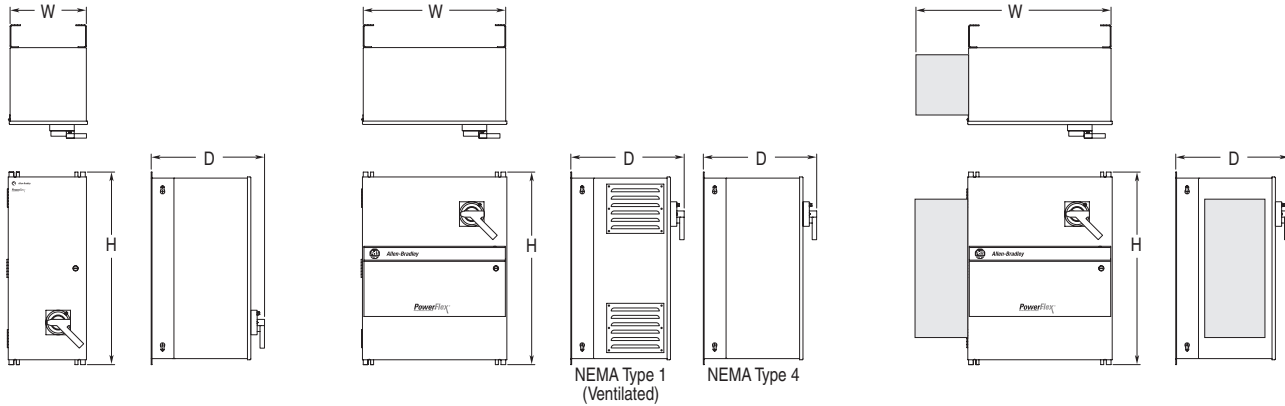

Figure 1

Figure 2

Figure 3

Maximum Enclosure Dimensions

Ratings				Enclosure Style for Flange Mounted Drives															
ND Hp	HD Hp	Drive Frame Size	Power Flex 70 Flange Drive Cat. No.	NEMA Type 1, Option Code A				NEMA Type 4 Indoor, Option Code D				NEMA Type 12 Indoor, Option Code G				NEMA Type 3/4, Option Code E			
				B0, C1, C5, S1, S9...S13, S16, P1...P3 or P6, Drive Mounted Options & All HIMs		All Options		B0, C1, C5, S1, S9...S13, S16, P1...P3 or P6, Drive Mounted Options & All NEMA 4 HIMs		All Options Less Line Reactor		All Options		B0, C1, C5, S1, S9...S13, S16, P1...P3 or P6, Drive Mounted Options		All Options Less Line Reactor		All Options	
				Figure	Style	Figure	Style	Figure	Style	Figure	Style	Figure	Style	Figure	Style	Figure	Style	Figure	Style
480V ac, Three-Phase Drives																			
0.5	0.33	A	D1P1	1	1	2	3	1	1	2	3	2	3	1	1	2	3	2	3
1.0	0.75	A	D2P1	1	1	2	3	1	1	2	3	2	3	1	1	2	3	2	3
2.0	1.5	A	D3P4	1	1	2	3	1	1	2	3	2	3	1	1	2	3	2	4
3.0	2.0	B	D5P0	1	1	2	3	1	1	2	3	2	4	1	1	2	3	2	5
5.0	3.0	B	D8P0	1	1	2	3	1	1	2	3	2	4	1	1	2	3	2	5
7.5	5.0	C	D011	1	1	2	3	1	1	2	3	2	4	1	1	2	3	2	5
10	7.5	C	D014	1	1	2	3	1	1	2	3	2	4	1	1	2	3	2 or 3	5 or 8
15	10	D	D022	1	1	2	4	1	1	2	4	2	5	16	1	2	4	2 or 3	5 or 8
20	15	D	D027	1	1	2	4	1	1	2	4	2	5	1	1	2	4	3	8
25	20	D	D034	1	1	2	4	1	1	2	4	2	5	1	1	2	5	3	8
30	25	D	D040	1	1	2	4	1	1	2	4	2	5	1	1	2	5	3	8
40	30	E	D052	1	2	2	6	1	2	2	6	2	7	1	2	2	6	3	9
50	40	E	D065	1	2	2	6	1	2	2	6	2	7	1	2	2	6	3	9

① Figure 2, Style 5 when one line reactor selected. Figure 3, Style 8 when two line reactors selected.

Enclosure Dimensions

Figure	Style	Enclosure Rating	Option Code (Position d)	Dimensions	
				H x W x D (mm)	H x W x D (in)
1	1	NEMA 1	A	812.8 x 330.2 x 484.1	32 x 13 x 19.06
1	2	NEMA 1	A	1,270.0 x 406.4 x 484.1	50 x 16 x 19.06
2	3	NEMA 1	A	812.8 x 609.6 x 484.1	32 x 24 x 19.06
2	4	NEMA 1	A	965.2 x 609.6 x 484.1	38 x 24 x 19.06
2	6	NEMA 1	A	1,270.0 x 762.0 x 484.1	50 x 30 x 19.06
1	1	NEMA 4/12 Indoor, NEMA 4 Outdoor	D, G, E	812.8 x 330.2 x 484.1	32 x 13 x 19.06
1	2	NEMA 4/12 Indoor, NEMA 4 Outdoor	D, G, E	1,270.0 x 406.4 x 484.1	50 x 16 x 19.06
2	3	NEMA 4/12 Indoor, NEMA 4 Outdoor	D, G, E	812.8 x 609.6 x 484.1	32 x 24 x 19.06
2	4	NEMA 4/12 Indoor, NEMA 4 Outdoor	D, G, E	965.2 x 609.6 x 484.1	38 x 24 x 19.06
2	5	NEMA 4/12 Indoor, NEMA 4 Outdoor	D, G, E	1,270.0 x 609.6 x 484.1	50 x 24 x 19.06
2	6	NEMA 4/12 Indoor, NEMA 4 Outdoor	D, G, E	1,270.0 x 762.0 x 484.1	50 x 30 x 19.06
2	7	NEMA 4/12 Indoor, NEMA 4 Outdoor	D, G, E	1,270.0 x 914.4 x 484.1	50 x 36 x 19.06
3	8	NEMA 4/12 Indoor, NEMA 4 Outdoor	D, G, E	812.8 x 831.9 x 484.1	50 x 32.75 x 19.06
3	9	NEMA 4/12 Indoor, NEMA 4 Outdoor	D, G, E	1,270.0 x 984.3 x 484.1	50 x 38.75 x 19.06







① Depth includes 6.35 mm (2.5 in) for Operator Handle when ordered.

Modified Configured Drives Program

- Drive Packages beyond the Catalog Configured Drives Program
- Enhanced and Standard Control
- Defined and Undefined Options
- Pre-determined Options or Custom Quotation

Standard Drive Specifications

Category	Specification																																																	
Protection	<table border="1"> <thead> <tr> <th>Drive</th> <th>200-208V</th> <th>240V</th> <th>380/400</th> <th>480V</th> <th>600V</th> <th>690V</th> </tr> </thead> <tbody> <tr> <td>AC Input Overvoltage Trip:</td> <td>247VAC</td> <td>285VAC</td> <td>475VAC</td> <td>570VAC</td> <td>690VAC</td> <td></td> </tr> <tr> <td>AC Input Undervoltage Trip:</td> <td>120VAC</td> <td>138VAC</td> <td>233VAC</td> <td>280VAC</td> <td>345VAC</td> <td></td> </tr> <tr> <td>Bus Overvoltage Trip:</td> <td>405VDC</td> <td>405VDC</td> <td>810VDC</td> <td>810VDC</td> <td>1013VDC</td> <td></td> </tr> <tr> <td>Bus Undervoltage Output Shutoff:</td> <td>300VDC</td> <td>300VDC</td> <td>407V DC</td> <td>407V DC</td> <td>508V DC</td> <td></td> </tr> <tr> <td>Bus Undervoltage Fault Level:</td> <td>160VDC</td> <td>160VDC</td> <td>300VDC</td> <td>300VDC</td> <td>375VDC</td> <td></td> </tr> <tr> <td>Nominal Bus Voltage:</td> <td>281VDC</td> <td>324VDC</td> <td>540VDC</td> <td>648VDC</td> <td>810VDC</td> <td></td> </tr> </tbody> </table>	Drive	200-208V	240V	380/400	480V	600V	690V	AC Input Overvoltage Trip:	247VAC	285VAC	475VAC	570VAC	690VAC		AC Input Undervoltage Trip:	120VAC	138VAC	233VAC	280VAC	345VAC		Bus Overvoltage Trip:	405VDC	405VDC	810VDC	810VDC	1013VDC		Bus Undervoltage Output Shutoff:	300VDC	300VDC	407V DC	407V DC	508V DC		Bus Undervoltage Fault Level:	160VDC	160VDC	300VDC	300VDC	375VDC		Nominal Bus Voltage:	281VDC	324VDC	540VDC	648VDC	810VDC	
	Drive	200-208V	240V	380/400	480V	600V	690V																																											
	AC Input Overvoltage Trip:	247VAC	285VAC	475VAC	570VAC	690VAC																																												
	AC Input Undervoltage Trip:	120VAC	138VAC	233VAC	280VAC	345VAC																																												
	Bus Overvoltage Trip:	405VDC	405VDC	810VDC	810VDC	1013VDC																																												
	Bus Undervoltage Output Shutoff:	300VDC	300VDC	407V DC	407V DC	508V DC																																												
	Bus Undervoltage Fault Level:	160VDC	160VDC	300VDC	300VDC	375VDC																																												
	Nominal Bus Voltage:	281VDC	324VDC	540VDC	648VDC	810VDC																																												
	All Drives																																																	
	Heat Sink Thermistor:	Monitored by microprocessor overtemp trip																																																
Drive Overcurrent Trip																																																		
Software Current Limit:	20-160% of rated current																																																	
Hardware Current Limit:	200% of rated current (typical)																																																	
Instantaneous Current Limit:	220-300% of rated current (dependent on drive rating)																																																	
Line transients:	up to 6000 volts peak per IEEE C62.41-1991																																																	
Control Logic Noise Immunity:	Showering arc transients up to 1500V peak																																																	
Power Ride-Thru:	15 milliseconds at full load																																																	
Logic Control Ride-Thru:	0.5 seconds minimum, 2 seconds typical																																																	
Ground Fault Trip:	Phase-to-ground on drive output																																																	
Short Circuit Trip:	Phase-to-phase on drive output																																																	
Environment	Altitude:	1000 m (3300 ft) max. without derating																																																
	Maximum Surrounding Air Temperature without derating:																																																	
	IP20, NEMA/UL Type 1:	0 to 50 degrees C (32 to 122 degrees F)																																																
	Flange Mount:	0 to 50 degrees C (32 to 122 degrees F)																																																
	IP66, NEMA/UL Type 4X/12 indoor:	0 to 40 degrees C (32 to 104 degrees F)																																																
	Storage Temperature (all const.):	-40 to 70 degrees C (-40 to 158 degrees F)																																																
Atmosphere	Important: Drive must not be installed in an area where the ambient atmosphere contains volatile or corrosive gas, vapors or dust. If the drive is not going to be installed for a period of time, it must be stored in an area where it will not be exposed to a corrosive atmosphere.																																																	
Relative Humidity:	5 to 95% non-condensing																																																	
Shock:	15G peak for 11ms duration (±1.0 ms)																																																	
Vibration	0.152 mm (0.006 in.) displacement, 1G peak																																																	

Category	Specification			
Agency Certification	Type 1, IP30	Flange Type	Type 4X/12, IP66 Indoor	
	✓	✓	✓	 Listed to UL508C and CAN/CSA-C2.2 No. 14-M91
		✓		Listed to UL508C for plenums (Rear heatsink only)
	✓	✓	✓	 Marked for all applicable European Directives ⁽¹⁾ EMC Directive (89/336/EEC) EN 61800-3 Adjustable Speed electrical power drive systems Low Voltage Directive (73/23/EEC) EN 50178 Electronic Equipment for use in Power Installations
	✓	✓	✓	 Compliant with IEC 61800-3:2004
			✓	 Certified to Criteria C-2, 1983.
	✓	✓	✓	   Certified to EN 954-1, Category 3 for 240V, 400V, and 480V ratings of PowerFlex 70 Enhanced Control with DriveGuard Safe-Off option.
	✓	✓	✓	TUV Approved to EN 954-1, Category 3 for 600V ratings of PowerFlex 70 Enhanced Control with DriveGuard Safe-Off option.
✓	✓	✓	RINA (Registro Italiano Navale - marine certification)	
The drive is also designed to meet the appropriate portions of the following specifications: NFPA 70 - US National Electrical Code NEMA ICS 3.1 - Safety standards for Construction and Guide for Selection, Installation and Operation of Adjustable Speed Drive Systems. IEC 146 - International Electrical Code.				
Electrical	Voltage Tolerance:		-10% of minimum, +10% of maximum. See page C-17 for Full Power and Operating Range.	
	Frequency Tolerance:		47-63 Hz.	
	Input Phases:		Three-phase input provides full rating for all drives. Single-phase operation provides 50% of rated current. Refer to page 23 for additional information.	
	Displacement Power Factor (all drives):		0.98 across speed range.	
	Efficiency:		97.5% at rated amps, nominal line volts.	
	Maximum Short Circuit Rating:		200,000 Amps symmetrical.	
	Max. Short Circuit Current Rating: Using Recommended Fuse or Circuit Breaker Type		Maximum short circuit current rating to match specified fuse/circuit breaker capability.	
Control	Method:		Sine coded PWM with programmable carrier frequency. Ratings apply to all drives.	
	Carrier Frequency:		2, 3, 4, 5, 6, 7, 8, 9 & 10 kHz Standard . 2, 4, 8 & 12 kHz EC . Drive rating based on 4 kHz.	
	Output Voltage Range:		0 to rated motor voltage	
	Output Frequency Range:		0 to 400 Hz Standard . 0 to 500 Hz EC .	
	Frequency Accuracy Digital Input: Analog Input:		Within ±0.01% of set output frequency. Within ±0.4% of maximum output frequency.	

Category	Specification		
Control <i>(continued)</i>	Frequency Control - Speed Regulation	with Slip Compensation (V/Hz Mode) 0.5% of base speed across 40:1 speed range 40:1 operating range 10 rad/sec bandwidth	
		with Slip Compensation (Sensorless Vector Mode) 0.5% of base speed across 80:1 speed range 80:1 operating range 20 rad/sec bandwidth	
		with feedback (Sensorless Vector Mode) EC 0.1% of base speed across 80:1 speed range 80:1 operating range 20 rad/sec bandwidth	
	Speed Control - Speed Regulation	without feedback (Vector Control Mode) EC 0.1% of base speed across 120:1 speed range 120:1 operating range 30 rad/sec bandwidth	
		with feedback (Vector Control Mode) EC 0.001% of base speed across 120:1 speed range 1000:1 operating range 125 rad/sec bandwidth	
	Torque Regulation	without feedback +/-10% EC	
		with feedback +/-5% EC	
	Selectable Motor Control:	Sensorless Vector with full tuning. Standard V/Hz with full custom capability and vector control.	
	Stop Modes:	Multiple programmable stop modes including - Ramp, Coast, DC-Brake, FastBrake, Ramp-to-Hold and S-curve.	
	Accel/Decel:	Two independently programmable accel & decel times. Each time may be programmed from 0-3600 seconds in 0.1 sec. increments	
Intermittent Overload:	110% Overload capability for up to 1 minute 150% Overload capability for up to 3 seconds		
Current Limit Capability:	Proactive Current Limit programmable from 20 to 160% of rated output current. Independently programmable proportional and integral gain.		
Electronic Motor Overload Protection:	Class 10 protection with speed sensitive response. Investigated by U.L. to comply with N.E.C. Article 430. U.L. File E59272, volume 12.		
Encoder	Type:	Incremental, dual channel	
	Supply:	5V/12V Configurable +/-5%	
	Quadrature:	90° +/-27° at 25° C.	
	Duty Cycle:	50% +10%	
	Requirements	Encoders must be line driver type, quadrature (dual channel) or pulse (single channel), single-ended or differential and capable of supplying a minimum of 10 mA per channel. The Encoder Interface Board accepts 5V or 12V DC square-wave with a minimum high state voltage of 3.5V DC (5V mode) and 7.0V DC (12V mode). Maximum low state voltage is 1V DC (for both 5V and 12V modes). Maximum input frequency is 250 kHz.	

(1) Applied noise impulses may be counted in addition to the standard pulse train causing erroneously high [Pulse Freq] readings.

Watts Loss (Rated Load, Speed & PWM)⁽¹⁾

Voltage	ND HP	External Watts	Internal Watts	Total Watts Loss
208V	0.5	12.2	19.2	31.4
	1.0	30.7	20.5	51.2
	2.0	44.6	22.6	67.2
	3.0	67.3	25.4	92.7
	5.0	141.3	33.2	174.5
	7.5	205.7	34.2	239.9
	10	270.4	48.1	318.5
	15	385.6	40.3	425.9
	20	494.6	44.9	539.5
	25	650.7	51.6	702.3
240V	0.5	12.2	19.2	31.4
	1.0	30.7	20.5	51.2
	2.0	44.6	22.6	67.2
	3.0	67.3	25.4	92.7
	5.0	141.3	33.2	174.5
	7.5	205.7	34.2	239.9
	10	270.4	48.1	318.5
	15	385.6	40.3	425.9
	20	494.6	44.9	539.5
	25	650.7	51.6	702.3
400V	0.37	11.5	17.9	29.4
	0.75	27.8	19.5	47.3
	1.5	43.6	21.6	65.2
	2.2	64.6	24.0	88.6
	4.0	99.5	28.2	127.7
	5.5	140.0	27.8	167.8
	7.5	193.3	32.0	225.3
	11	305.4	34.2	339.6
	15	432.9	42.9	475.8
	18.5	363.8	40.5	404.3
	22	396.8	41.5	438.3
	30	500.8	50.0	550.8
	37	632.0	57.7	689.7
480V	0.5	11.5	17.9	29.4
	1.0	27.8	19.5	47.3
	2.0	43.6	21.6	65.2
	3.0	64.6	24.0	88.6
	5.0	99.5	28.2	127.7
	7.5	140.0	27.8	167.8
	10	193.3	32.0	225.3
	15	305.4	34.2	339.6
	20	432.9	42.9	475.8
	25	363.8	40.5	404.3
	30	396.8	41.5	438.3
	40	500.8	50.0	550.8
	50	632.0	57.7	689.7
600V	0.5	11.5	17.9	29.4
	1.0	27.8	19.5	47.3
	2.0	43.6	21.6	65.2
	3.0	64.6	24.0	88.6
	5.0	99.5	28.2	127.7
	7.5	140.0	27.8	167.8
	10	193.3	32.0	225.3
	15	305.4	34.2	339.6
	20	432.9	42.9	475.8
	25	281.4	42.4	323.8
	30	311.9	43.4	355.3
	40	389.9	51.8	441.7
	50	501.4	59.9	561.3

⁽¹⁾ Worst case condition including Vector Control board, HIM and Communication Module

Voltage Tolerance

Drive Rating	Nominal Line Voltage	Nominal Motor Voltage	Drive Full Power Range	Drive Operating Range
200-240	200	200†	200-264	180-264
	208	208	208-264	
	240	230	230-264	
380-400	380	380†	380-528	342-528
	400	400	400-528	
	480	460	460-528	
500-600	600	575†	575-660	432-660

Drive Full Power Range = Nominal Motor Voltage to Drive Rated Voltage + 10%.
 Rated current is available across the entire Drive Full Power Range

Drive Operating Range = Lowest† Nominal Motor Voltage - 10% to Drive Rated Voltage + 10%.
 Drive Output is linearly derated when Actual Line Voltage is less than the Nominal Motor Voltage

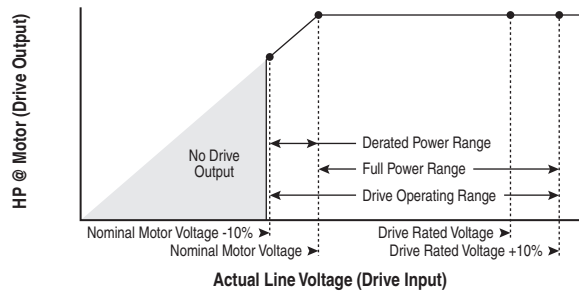

Example:

Calculate the maximum power of a 5 HP, 460V motor connected to a 480V rated drive supplied with 342V Actual Line Voltage input.

- ² Actual Line Voltage / Nominal Motor Voltage = 74.3%
- ² 74.3% × 5 HP = 3.7 HP
- ² 74.3% × 60 Hz = 44.6 Hz

At 342V Actual Line Voltage, the maximum power the 5 HP, 460V motor can produce is 3.7 HP at 44.6 Hz.

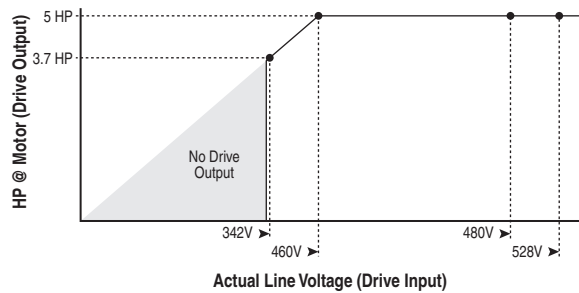

Derating Guidelines

Altitude and Efficiency

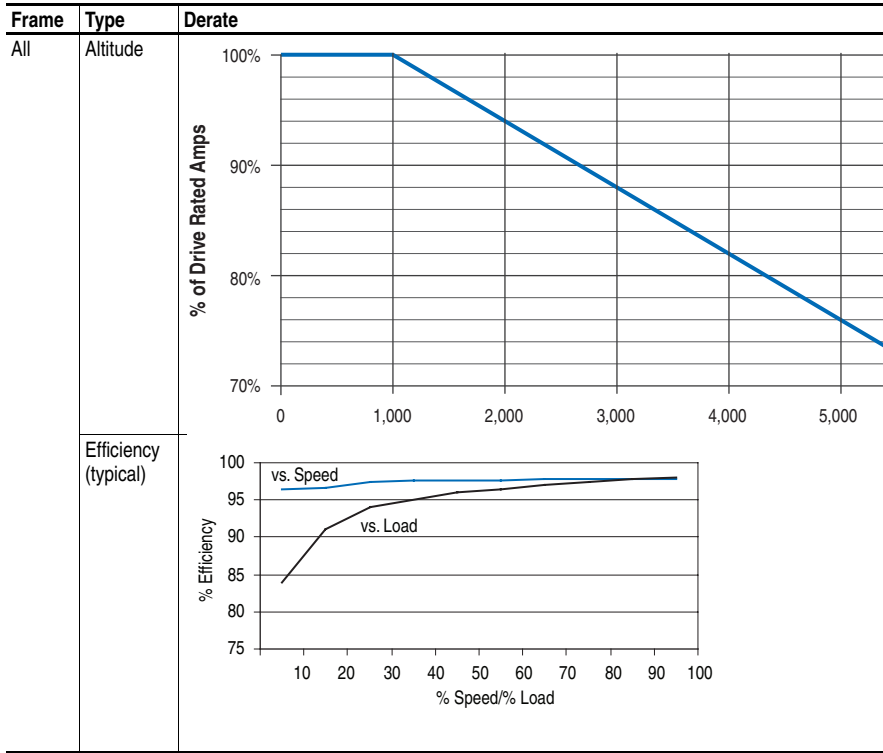

Ambient Temperature/Load

240V AC

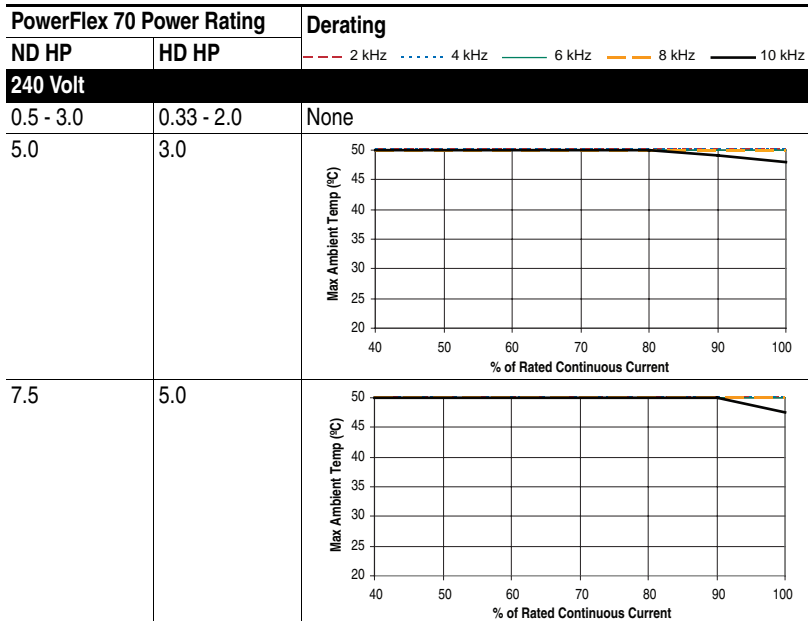

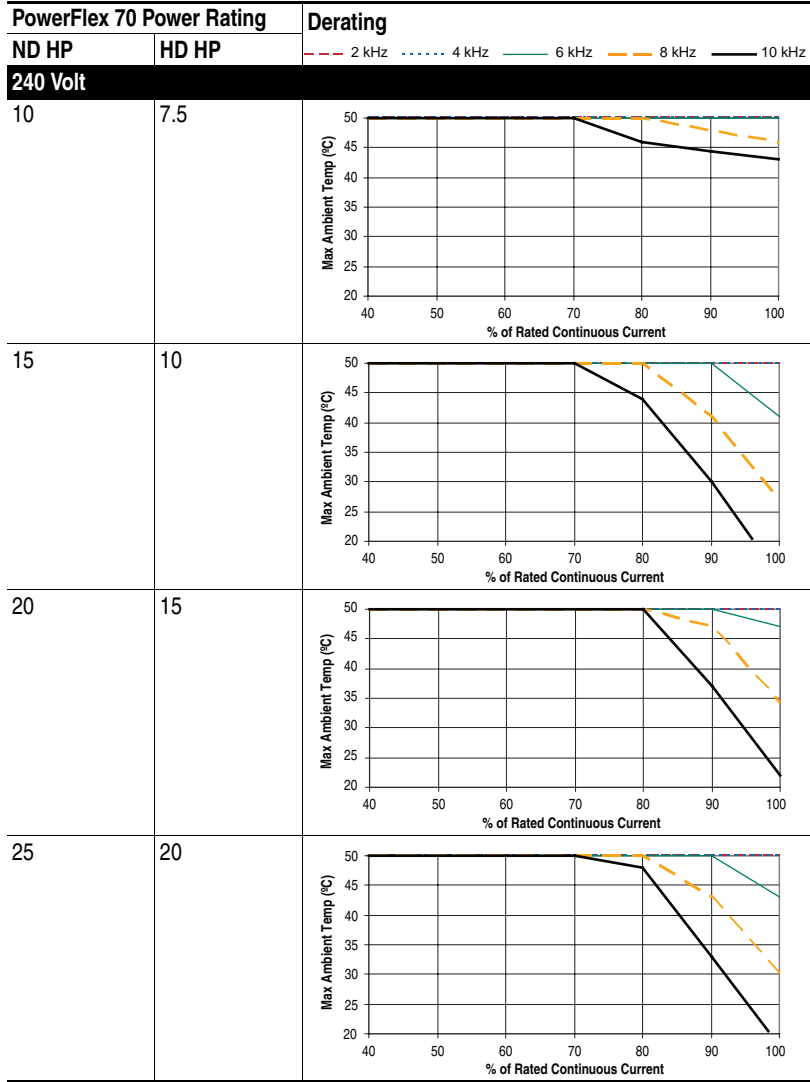

PowerFlex 70 Technical Data

400V AC

PowerFlex 70 Power Rating		Derating
ND kW	HD kW	
400 Volt		
0.37 - 5.5	0.25 - 4.0	None
7.5	5.5	
11	7.5	
15	11	
18.5	15	
22	18.5	
30	22	

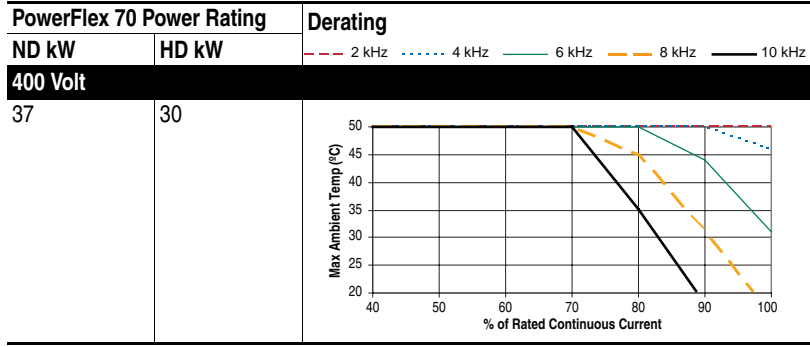

480V AC

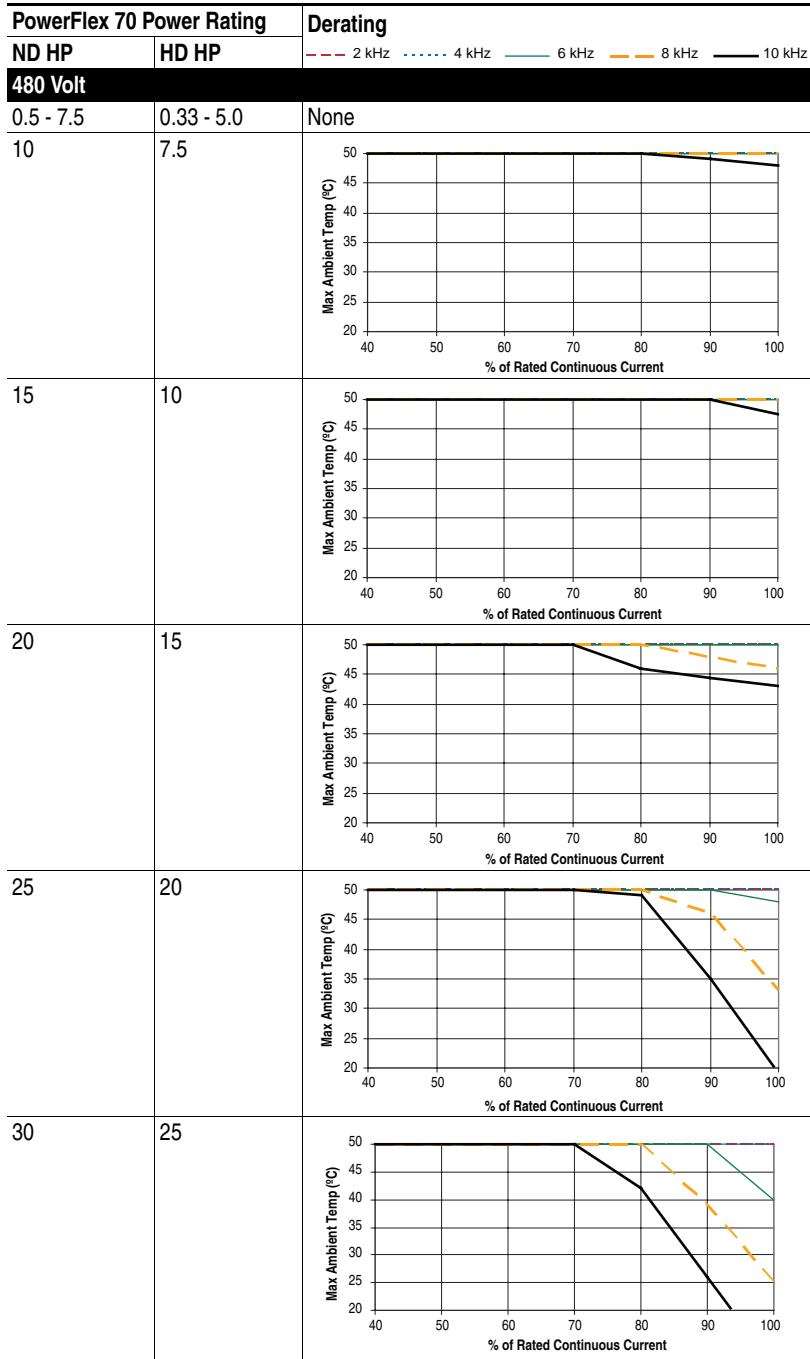

PowerFlex 70 Power Rating		Derating
ND HP	HD HP	
480 Volt		
40	30	
50	40	

600V AC

PowerFlex 70 Power Rating		Derating
ND HP	HD HP	
600 Volt		
0.5 - 5.0	0.33 - 3.0	None
7.5	5.0	
10	7.5	
15	10	

PowerFlex 70 Power Rating		Derating
ND HP	HD HP	
600 Volt		
20	15	
25	20	
30	25	
40	30	
50	40	

PowerFlex, Zero Stacking, Force Technology, DriveExplorer, DriveTools SP, DPI and PanelView are trademarks of Rockwell Automation.
Trademarks not belonging to Rockwell Automation are property of their respective companies.

www.rockwellautomation.com

Power, Control and Information Solutions Headquarters

Americas: Rockwell Automation, 1201 South Second Street, Milwaukee, WI 53204 USA, Tel: (1) 414.382.2000, Fax: (1) 414.382.4444

Europe/Middle East/Africa: Rockwell Automation, Vorstlaan/Boulevard du Souverain 36, 1170 Brussels, Belgium, Tel: (32) 2 663 0600, Fax: (32) 2 663 0640

Asia Pacific: Rockwell Automation, Level 14, Core F, Cyberport 3, 100 Cyberport Road, Hong Kong, Tel: (852) 2887 4788, Fax: (852) 2508 1846