

Technical characteristics

 + 50°C + 0°C 230 - 240V a.c. 50Hz	 1 x 2.5 mm ² 2 x 1.5 mm ²	Incandescent	Halogen	Fluorescent tube	Wirewound transformer	Electronic transformer	Compact Fluorescent	LED	Fan motor
Max load		1200W	1200W	500VA	500VA	500VA	500VA	500VA	500VA

Minimum load = 10VA for all load types

Wiring

- Connect optional Secondary Control Buttons (EM800SLAVE) to enable switching from multiple locations.

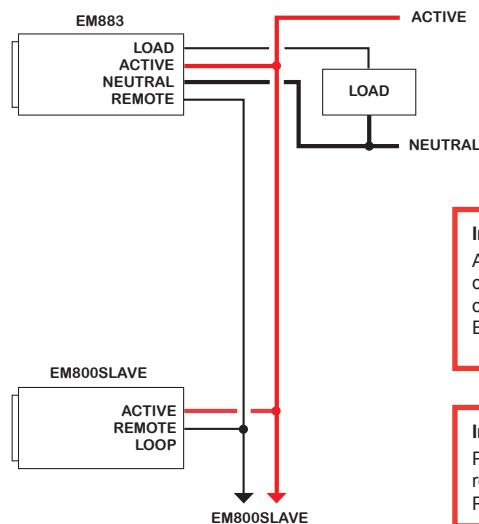

Important:
An unlimited number of EM800SLAVE can be connected to an EM883. However, the total length of the remote wire used to interconnect all of the EM800SLAVE should not exceed 50 metres.

Important:
Power factor correction capacitors must be either removed or placed on the line side of the Electronic Push Switch.

Operation

- Press the button to turn the electronic switch on. The LED indicator will shine bright when the switch is on.
- Press the button again to turn the electronic switch off.

LED Indicator

- The colour of the LED indicator can be either red or blue. In addition, when the switch is off the LED indicator can either glow faintly or be off completely. The four possible modes are as follows:

Mode	Status of LED indicator	
	Switch on	Switch off
1	Bright red	Faint red
2	Bright blue	Faint blue
3	Bright red	Off
4	Bright blue	Off

- To change between modes, press and hold the push button for at least 10 seconds. This will select the next mode in the sequence above.

Important:

The remote wire only needs to be connected if the multi-way switching feature is used. Remove the protective cover from the wire, strip it to an appropriate length and join it to mains rated building wire using a Cat 401 or other suitable screw connector. Do not remove the protective cover from the wire if the multi-way switching feature will not be used.

Important:

Switches, powerpoints and other fixed wired products must be installed by an electrical contractor or similarly qualified person.

Warranty

Legrand Cat EM883 is warranted as here and after appears, against faulty material and/or workmanship for a period of one year from the day of purchase. The obligation of the manufacturer under this warranty is limited to servicing and replacing defective parts when the unit is returned to the authorised place of purchase, at the purchaser's cost. To obtain warranty repair, the purchase receipt should be returned with the product. This warranty becomes void on any unit which has been tampered with or damaged by accident, short circuited, loaded beyond rating or damaged otherwise by improper operation. The warranty is also conditional on the unit being installed by a licensed electrical contractor. Our goods come with guarantees that cannot be excluded under the Australian Consumer Law. You are entitled to a replacement or refund for a major failure and compensation for any other loss or damage. You are also entitled to have the goods repaired or replaced if the goods fail to be of acceptable quality and the failure does not amount to a major failure.

Customer Service

For all Customer Service and Technical Support please call Monday to Friday during business hours.

HPM Legrand Australia
1300 369 777
www.hpmlegrand.com.au

HPM Legrand New Zealand
0800 476 009
www.hpmlegrand.co.nz

ABN: 31 000 102 661