



Trade Audio Visual Products

**TRADE
MADE**
QUALITY MATERIALS FOR
THE TRADESMAN IN MIND

★ ★ ★ ★ ★
**100%
Australian
Owned**

Heavy Duty Articulated Television Wall Bracket for 32"- 85" Screens

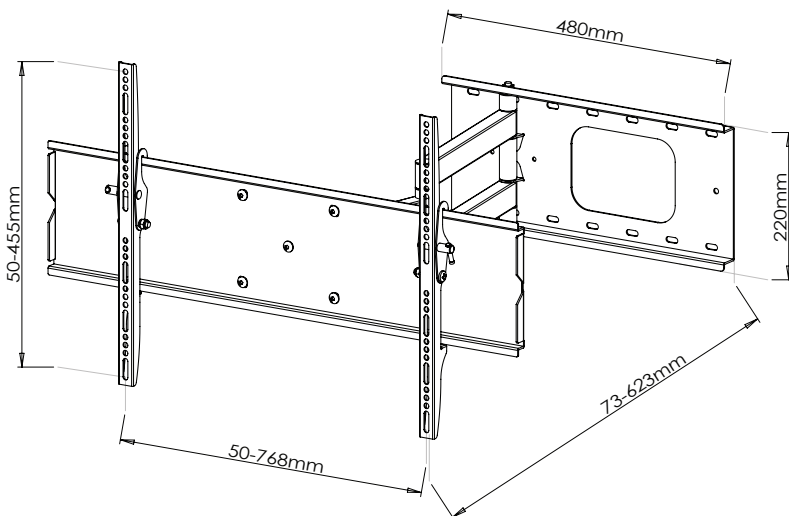

Digital Life Heavy Duty Universal Double Articulated Plasma/LCD/LED TV Wall Mount Bracket for screens sizes 32" to 85". Includes Tilt adjustment for anti-glare. Ideal for having to pull out and view the TV from different angles. Solid strong base plate for secure mounting, the double stud mount allows to hold up to 80kg.

Product Code: DLPLB126B

- For 32" to 85" Screens LED/LCD/Plasma
- Max VESA: 768mm x 455mm
- Max Weight: 80Kg
- Distance from Wall: 73-623mm
- Swivel: -90° to +90°
- Tilt: 0° to +12°
- Strong Heavy Duty Steel Construction
- Includes Intergrated Bubble Level
- Locking Bar for Anti-Theft
- Lifetime Warranty

Available Colours



Black