

Catalogue No: **T2HP12R6BN**

T2 HANDLE EXTENTION IP65 FOR 125 BLACK

Power Distribution and Protection > Circuit Breakers > Moulded Case Circuit Breakers > TemBreak2 Accessories > TemBreak 2 External Accessories 125 AF to 1600 AF > Handles - Extension Type T2HP (Plastic)



TB2 HP Extension IP65 Black Handle/Shaft Kit 125 AF



Representative Photo Only
(actual product may vary based on configuration selections)

SPECIFICATIONS

Compatible Product Series'	E125 S125
Details, compatible product series	E125, S125
Component Type MCCB	Handle / Mechanical Interlock
IP Rating	IP65
Material, Handle	Plastic Handle
Compatible Frame Size(s)	125 AF compatible

REFERENCES

IECEX Certificate	-
Supplier Declaration of Conformity:	-
Installation Guide:	-
User Manual:	-
Manufacturer Datasheet:	-
Manufacturer Catalogue & Product Selection:	-

Catalogue No: T2HP12R6BN

T2 HANDLE EXTENTION IP65 FOR 125 BLACK

Power Distribution and Protection > Circuit Breakers > Moulded Case Circuit Breakers > TemBreak2 Accessories > TemBreak 2 External Accessories 125 AF to 1600 AF > Handles - Extension Type T2HP (Plastic)



T2HP80

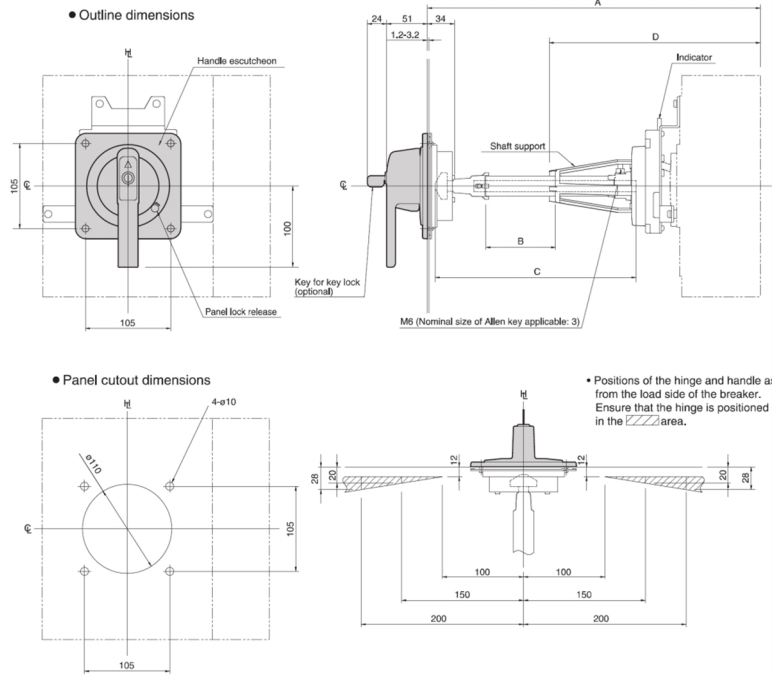

Dimension Diagram