

Earth Leakage Relay RD1E, 72mmx72mm Panel mount 24-150V DC



- Panel mount 72 mm
- I Δ n LED indication 20, 30, 40, 50% setting
- 2 change-over contacts
- Selectable 50% pre-trip or alarm contact
- Manual or automatic reset

Representative Photo Only
(actual product may vary based on configuration selections)

SPECIFICATIONS

Product Series	Delta 72-S
Component Type Power Distribution & Protection	Earth Leakage Relay
Details, Connection	Low voltage lines, with series TD transformer.
Input Frequency, Nom	50 Hz
Waveform	Sinusoidal (type AC) or chopped pulsating with superimposed D.C. (type A) according to EN60947-2 (annex Band M) IEC60947-2
Operational Frequency, Min	47 Hz min
Operational Frequency, Max	63 Hz max
Umin, Supply Voltage, DC, Min	20 V DC
Umax, Supply Voltage, DC, Max	150 V DC
Burden, Rated	2.5 VA
Power Dissipation, Max	2 W
Number of Setpoints	19
Setpoint Range(s)	Configurable 0.03 ... 30A
Configuration Method	Potentiometer / DIP-Switch
Trip Time, Max	5000 ms
Details, Indicator	Power ON: Green LED "ON". Alarm intervention: Red LED "Trip" + Relay switching. Ring current transformer - relay connection failure: Red LED "Trip" blinking + Relay switching.
Display Technology	LED Sequence
Reset Type	Manual local or Remote
Alarm Function	Yes
Details, Alarm	Trip contact and RED LED
Number of Alarm Contacts	2
Contact Configuration	2 CO

Catalogue No: **RD1EP21H**

ELR PANEL MOUNT 72 x 72 2C/O 20-150V DC

Power Distribution and Protection > Earth Leakage Protection > Earth Leakage Relays > IME Earth Leakage Relays and Toroids > Panel Mount Earth Leakage Relays > RD1EP Series



Reverse Polarity Protection	Yes Y/N
Details, Output(s)	1 SPDT alarm contact and 1 SPDT contact selectable alarm or pre-trip alarm.
Installation Category	III
Pollution Degree	2
Ui, Rated Insulation Voltage	450 V (rms)
Uimp, Impulse Withstand Voltage	5 kV
Terminal Type	Fast-On Crimp Terminal(s)
Mounting	Panel Mount
Material, Body / Housing	Plastic PC (Polycarbonate) self-extinguishing material
IP Rating, Front	IP40
IP Rating, Terminals	IP20
Height, Cutout	68 mm
Width, Cutout	68 mm
Frequency Tolerance	47...63 Hz
Non-operating residual current (IEC60755)	50% I Δ n
Intervention time t:	0, 0.15, 0.25, 0.5, 1.0, 2.5, and 5 s
Operating Temperature, Min	-5 °C min
Operating Temperature, Max	50 °C max
Storage Temperature, Min	-40 °C min
Storage Temperature, Max	70 °C max
Humidity Type	Suitable for tropical environments
Current set point I Δ n	0.03, 0.05, 0.075, 0.1, 0.15, 0.2, 0.3 3 ranges x1, x10, x100
Standards Compliance	EN 60947-2 IEC 60947-2 EN 60947-1 IEC 60947-1 IEC 60755 EN 60529 IEC 60529 EN 50081-1 EN 55011 EN 50082-2 AS 60947-2
Power On	Green LED
Details, Pre-Alarm	50% I Δ n relay switching
Visible Trip Indicator	Red LED
Relative Humidity, Average	50 %RH
Width	72 mm
Height	72 mm
Depth	86 mm
Weight	0.25 kg
RCD Type, AS/NZS 60947-2	A
I Δ n, Leakage Current, Max	30 A

Catalogue No: **RD1EP21H**

ELR PANEL MOUNT 72 x 72 2C/O 20-150V DC

Power Distribution and Protection > Earth Leakage Protection > Earth Leakage Relays > IME Earth Leakage Relays and Toroids > Panel Mount Earth Leakage Relays > RD1EP Series



REFERENCES

IECEX Certificate -

Supplier Declaration of Conformity: -

Installation Guide: -

User Manual: -

Manufacturer Datasheet: -

Manufacturer Catalogue & Product Selection: -

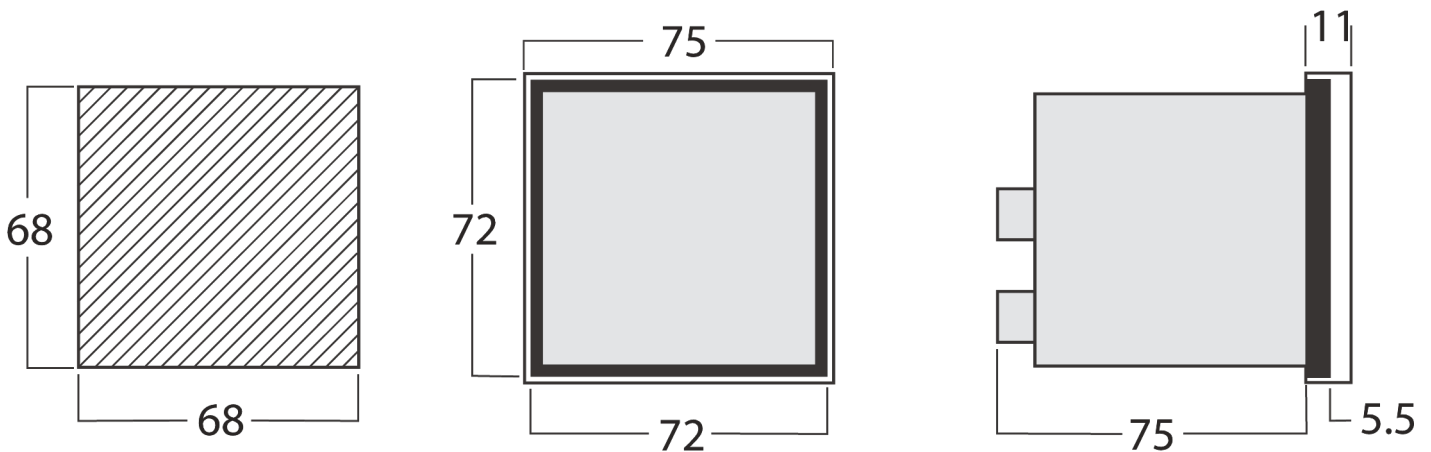

Dimension Diagram

Catalogue No: **RD1EP21H**

ELR PANEL MOUNT 72 x 72 2C/O 20-150V DC

Power Distribution and Protection > Earth Leakage Protection > Earth Leakage Relays > IME Earth Leakage Relays and Toroids > Panel Mount Earth Leakage Relays > RD1EP Series



S 291/123

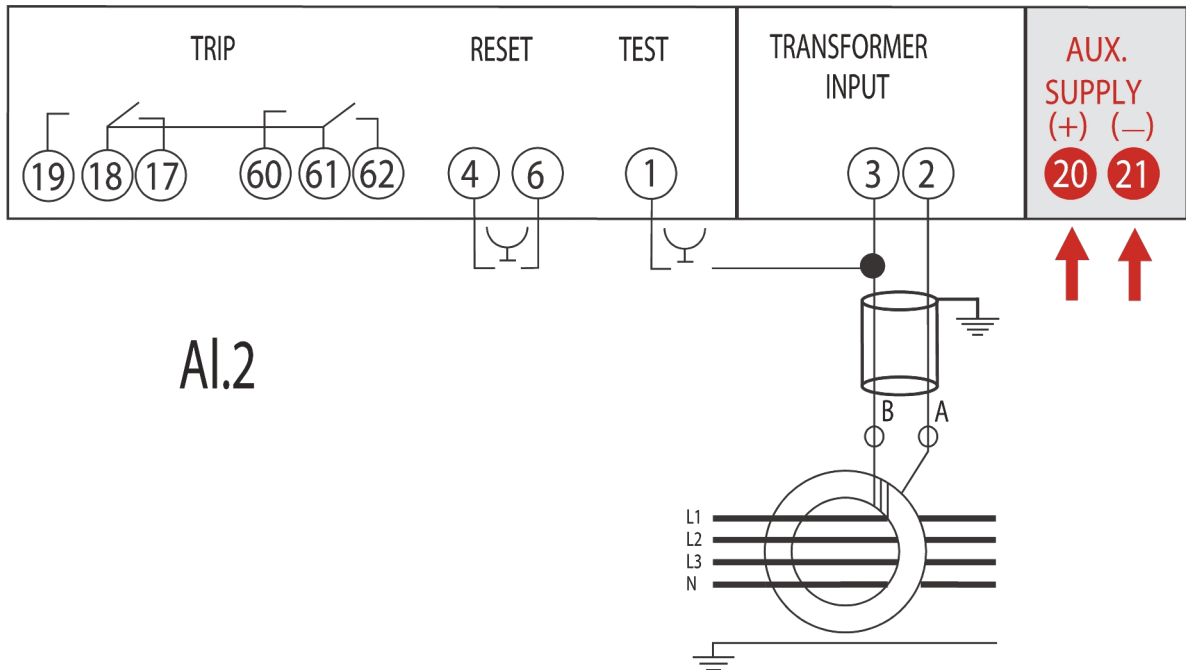

Connection / Wiring Diagram