

Catalogue No: **HVL 03103**

FAN HEATER 230V AC H80xW112xD47mm 150W

Enclosures and Climate Control > Climate Control > Heaters and Regulating Devices > Heaters > Anti-Condensation Fan Heaters > HVL031 Series - Slimline Fan Heaters



Representative Photo Only
(actual product may vary based on configuration selections)

Fan heater 230V AC H80xW112xD47mm 150W

- Ball bearing fan with 50,000 hour life
- Flat profile for small footprint
- Clip-on DIN rail fixing
- Temperature safety cut-out
- High air flow (35m³/hr on 100/15W models, 108m³/hr on 200W and above models)

SPECIFICATIONS

Product Series	HVL031
Component Type Heaters Filter Fans Regulating Devices	Fan Heater
Heating Capacity, Ambient 20°C	150 W @20°C
Material, Body / Housing	Aluminium, Die-Cast material
Heating Element	High Performance Cartridge
Rated Frequency	50 / 60 Hz
Pre-Fuse T (time delay)	1.25 A
Mounting (Multiple)	DIN-35 Rail Mount
Details, Installation Position	Vertical airflow (air outlet up) position
IP Rating	IP20
Protection Class, Heater	I Heater
Connection	3 pole screw connector 2.5 mm ² , clamping torque 0.8 Nm max
Integrated Thermostat	No Y/N
Optical Indicator	No Y/N
Fan Type	Axial fan, ball bearing
Airflow (free)	35 m ³ /hr
Service Life (fan)	50,000 hours at +25 degrees C
Temperature Safety Cut-out	Yes, with automatic reset to protect against overheating in case of fan failure
Height	80 mm
Width	112 mm
Depth	47 mm
Weight	0.6 kg
Operating Temperature, Min	-45 °C min
Operating Temperature, Max	70 °C max
Storage Temperature, Min	-45 °C min
Storage Temperature, Max	70 °C max
Relative Humidity, Max	90 %RH
Approvals	UL File no. E187294 (230V only: VDE)



Catalogue No: **HVL 03103**

FAN HEATER 230V AC H80xW112xD47mm 150W

Enclosures and Climate Control > Climate Control > Heaters and Regulating Devices > Heaters > Anti-Condensation Fan Heaters > HVL031 Series - Slimline Fan Heaters



REFERENCES	
IECEX Certificate	-
Supplier Declaration of Conformity:	-
Installation Guide:	-
User Manual:	-
Manufacturer Datasheet:	-
Manufacturer Catalogue & Product Selection:	-

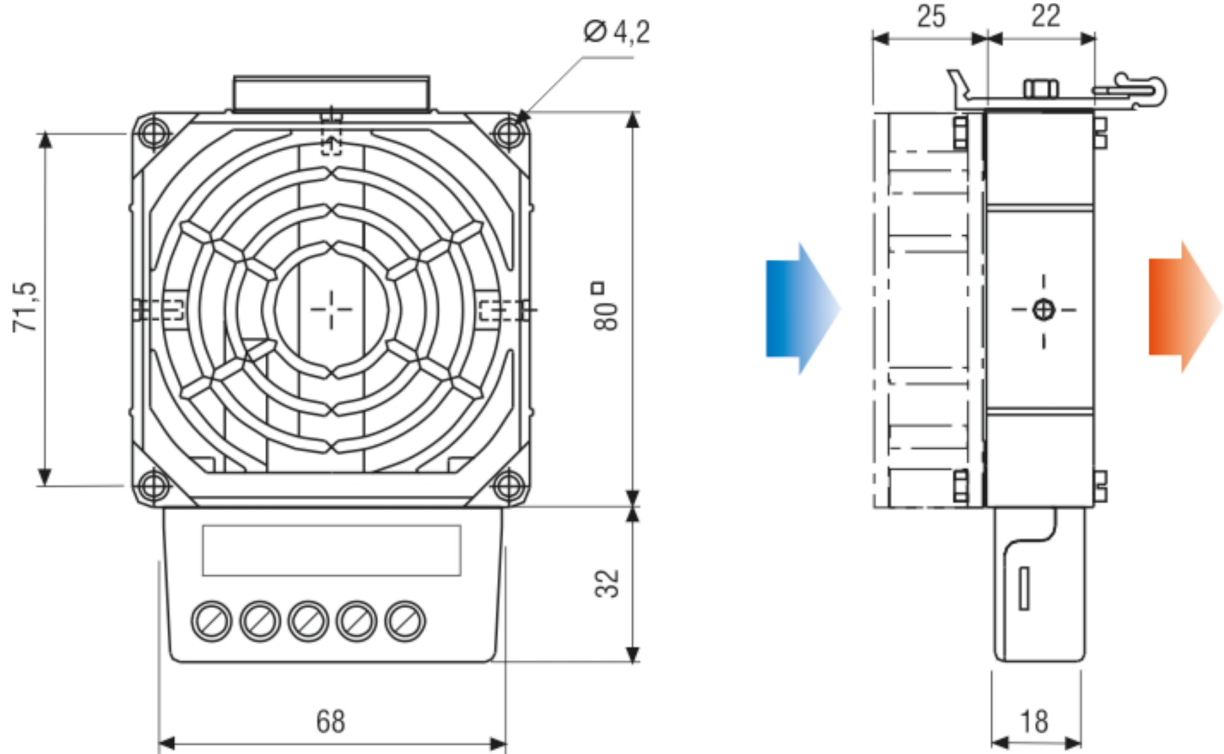

Dimension Diagram