

XCKJ50541H29

limit switch XCKJ - th.plastic roller lever var. length -
1NC+1NO - slow - M20



Main

| | |
|-------------------------------|---|
| Range of product | OsiSense XC |
| Series name | Standard format |
| Product or component type | Limit switch |
| Device short name | XCKJ |
| Sensor design | - |
| Body type | Fixed |
| Head type | Rotary head |
| Material | Metal |
| Body material | Zamak |
| Head material | Zamak |
| Fixing mode | By the body |
| Movement of operating head | Rotary |
| Type of operator | Spring return roller lever thermoplastic (variable length) |
| Type of approach | Lateral approach 1 or 2 programmable direction |
| Cable entry | 1 entry tapped for M20 x 1.5 cable gland, cable outer diameter: 7...13 mm |
| Number of poles | 2 |
| Contacts type and composition | 1 NC + 1 NO |
| Contact operation | Slow-break, break before make |

Complementary

| | |
|--|--|
| Switch actuation | By 30° cam |
| Electrical connection | Screw-clamp terminals, clamping capacity: 1 x 0.5...2 x 2.5 mm ² |
| Contacts insulation form | Zb |
| Number of steps | 1 |
| Positive opening | Without |
| Minimum torque for tripping | 0.25 N.m |
| Minimum actuation speed | 6 m/min |
| Maximum actuation speed | 1.5 m/s |
| [Ie] rated operational current | 3 A at 240 V, AC-15, A300 conforming to EN/IEC 60947-5-1 appendix A 0.27 A at 250 V, DC-13, Q300 conforming to EN/IEC 60947-5-1 appendix A |
| [Ithe] conventional enclosed thermal current | 10 A |
| [Ui] rated insulation voltage | 500 V degree of pollution 3 conforming to IEC 60947-1 300 V conforming to UL 508 300 V conforming to CSA C22.2 No 14 |
| Resistance across terminals | <= 25 MOhm conforming to IEC 60255-7 category 3 |
| [Uimp] rated impulse withstand voltage | 6 kV conforming to IEC 60664 6 kV conforming to IEC 60947-1 |
| Short-circuit protection | 10 A by gG cartridge fuse |
| Electrical durability | 5000000 cycles, DC-13, inductive load type, 120 V, 4 W, operating rate: <= 60 cyc/mn, load factor: 0.5 conforming to IEC 60947-5-1 appendix C 5000000 cycles, DC-13, inductive load type, 24 V, 10 W, operating rate: <= 60 cyc/mn, load factor: 0.5 conforming to IEC 60947-5-1 appendix C 5000000 cycles, DC-13, inductive load type, 48 V, 7 W, operating rate: <= 60 cyc/mn, load factor: 0.5 conforming to IEC 60947-5-1 appendix C |
| Mechanical durability | 30000000 cycles |
| Width | 40 mm |
| Height | 77 mm |

The information provided in this documentation contains general descriptions and/or technical characteristics of the products contained herein. This documentation is not intended as a substitute for and is not to be used for determining suitability or reliability of these products for specific user applications. It is the duty of any such user or integrator to perform the appropriate and complete risk analysis, evaluation and testing of the products with respect to the relevant specific application or use thereof. Neither Schneider Electric Industries SAS nor any of its affiliates or subsidiaries shall be responsible or liable for misuse of the information contained herein.

| | |
|-------------------------------|------------------------|
| Depth | 44 mm |
| Product weight | 0.485 kg |
| Terminals description ISO n°1 | (13-14)NO (21-22)NC |

Environment

| | |
|---------------------------------------|---|
| shock resistance | 50 gn (duration = 11 ms) conforming to IEC 60068-2-27 |
| vibration resistance | 25 gn (f = 10...500 Hz) conforming to IEC 60068-2-6 |
| IP degree of protection | IP66 conforming to IEC 60529 |
| IK degree of protection | IK07 conforming to EN 50102 |
| overvoltage category | Class I conforming to NF C 20-030 Class I conforming to IEC 61140 |
| ambient air temperature for operation | -25...70 °C |
| ambient air temperature for storage | -40...70 °C |
| protective treatment | TC |
| product certifications | CCC CSA UL |
| standards | CENELEC EN 50041 EN 60204-1 EN 60947-5-1 IEC 60204-1 IEC 60947-5-1 UL 508 CSA C22.2 No 14 |

Offer Sustainability

| | |
|----------------------------------|---|
| Sustainable offer status | Green Premium product |
| RoHS (date code: YYWW) | Compliant - since 1103 - Schneider Electric declaration of conformity |
| REACH | Reference not containing SVHC above the threshold |
| Product end of life instructions | Need no specific recycling operations |

Dimensions

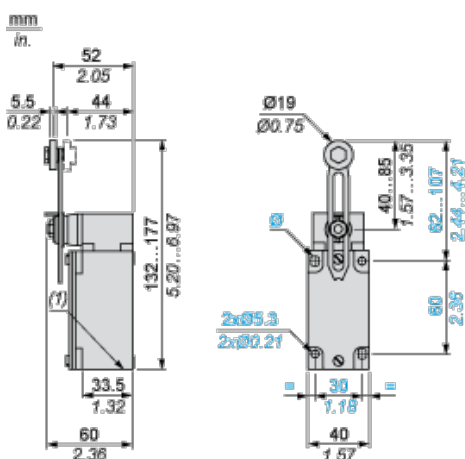

(1) 1 tapped entry M20 x 1.5

Mounting with Cable Entry

Position of Cable Gland

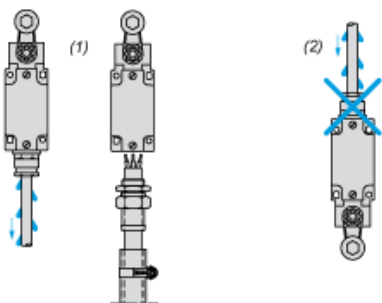

- (1) Recommended
- (2) To be avoided

Mounting with Rotary Heads and Levers

Type of Cam

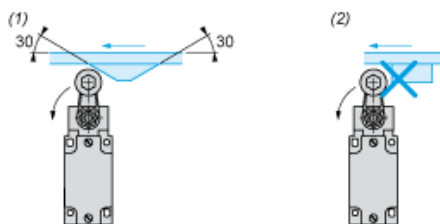

- (1) Recommended
- (2) To be avoided

Setting-up with Lever Head

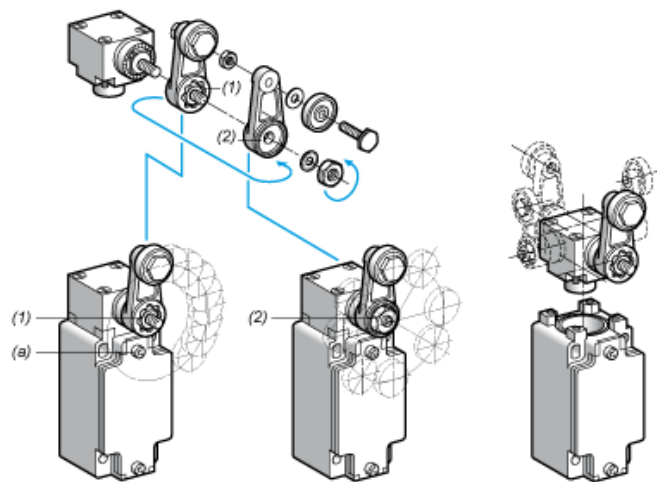

- (1) 5° steps throughout 360° / Tightening torque (Min : 1) (Max : 1.5)
- (2) 45° steps throughout 360° / Tightening torque (Min : 1) (Max : 1.5)
- (a) Tightening torque (Min : 1) (Max : 1.5)

Setting-up with Head ZCKE05

Direction of Actuation Programming

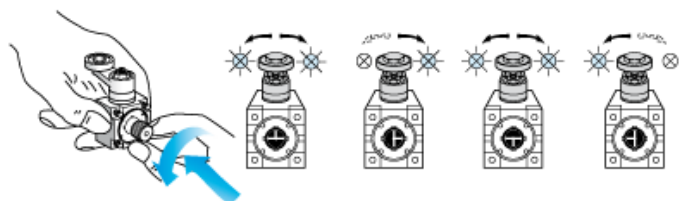

Wiring Diagram

2-pole NC + NO Break before Make, Slow Break

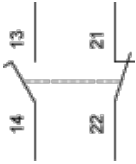

Characteristics of Actuation

Switch Actuation by 30° Cam

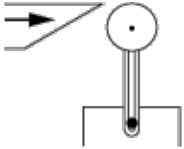

Functionnal Diagram

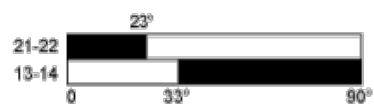

- (1)
- (2)

- (1) Closed
- (2) Open