

LC1F800MW

TeSys F contactor - 3P (3 NO) - AC-3 - ≤ 440 V
800 A - coil 220...230 V DC



Main

Range	TeSys
Product name	TeSys F
Product or component type	Contacteur
Device short name	LC1F
Contacteur application	Motor control Resistive load
Utilisation category	AC-1 AC-3 AC-4
Poles description	3P
Pole contact composition	3 NO
[Ue] rated operational voltage	≤ 1000 V AC 50/60 Hz ≤ 460 V DC
[Ie] rated operational current	1000 A (≤ 40 °C) at ≤ 440 V AC AC-1 800 A (≤ 55 °C) at ≤ 440 V AC AC-3
Motor power kW	450 kW at 440 V AC 50/60 Hz AC-3 450 kW at 1000 V AC 50/60 Hz AC-3 450 kW at 500 V AC 50/60 Hz AC-3 110 kW at 400 V AC 50/60 Hz AC-4 450 kW at 380...400 V AC 50/60 Hz AC-3 450 kW at 415 V AC 50/60 Hz AC-3 250 kW at 220...230 V AC 50/60 Hz AC-3 475 kW at 660...690 V AC 50/60 Hz AC-3
[Uc] control circuit voltage	220...230 V DC 220...240 V AC 40...400 Hz
Coil type	Standard

Complementary

[Uimp] rated impulse withstand voltage	8 kV
Overvoltage category	III
[Ith] conventional free air thermal current	1000 A at ≤ 40 °C
Rated breaking capacity	6400 A conforming to IEC 60947-4-1
[Icw] rated short-time withstand current	5500 A ≤ 40 °C 10 s 4600 A ≤ 40 °C 30 s 3600 A ≤ 40 °C 1 min 2600 A ≤ 40 °C 3 min 1700 A ≤ 40 °C 10 min
Associated fuse rating	1000 A gG at ≤ 440 V 800 A aM at ≤ 440 V
Average impedance	0.12 mOhm at 50 Hz - Ith 1000 A
[Ui] rated insulation voltage	1000 V conforming to IEC 60947-4-1 1500 V conforming to VDE 0110 group C
Power dissipation per pole	120 W AC-1 77 W AC-3
Mounting support	Plate
Standards	EN 60947-1 EN 60947-4-1 IEC 60947-1 IEC 60947-4-1 JIS C8201-4-1
Product certifications	ABS CCC CSA RMRoS

The information provided in this documentation contains general descriptions and/or technical characteristics of the products contained herein. This documentation is not intended as a substitute for and is not to be used for determining suitability or reliability of these products for specific user applications. It is the duty of any such user or integrator to perform the appropriate and complete risk analysis, evaluation and testing of the products with respect to the relevant specific application or use thereof. Neither Schneider Electric Industries SAS nor any of its affiliates or subsidiaries shall be responsible or liable for misuse of the information contained herein.

UL
CB

Connections - terminals	Control circuit : screw clamp terminals 2 cable(s) 1...2.5 mm ² - cable stiffness: flexible - with cable end Control circuit : screw clamp terminals 1 cable(s) 1...4 mm ² - cable stiffness: flexible - without cable end Control circuit : screw clamp terminals 2 cable(s) 1...4 mm ² - cable stiffness: flexible - without cable end Control circuit : screw clamp terminals 1 cable(s) 1...4 mm ² - cable stiffness: flexible - with cable end Control circuit : screw clamp terminals 1 cable(s) 1...4 mm ² - cable stiffness: solid - without cable end Control circuit : screw clamp terminals 2 cable(s) 1...4 mm ² - cable stiffness: solid - without cable end Power circuit : bolted connection Power circuit : bar 2 x (60 x 5 mm)
Tightening torque	Control circuit : 1.2 N.m Power circuit : 58 N.m
Control circuit voltage limits	0.85...1.1 U _c at 55 °C operational 0.3...0.5 U _c at 55 °C drop-out
Inrush power in W	1900 W at 20 °C
Hold-in power consumption in W	12 W at 20 °C
Heat dissipation	12 W
Operating time	40...50 ms opening 60...80 ms closing
Mechanical durability	5 Mcycles
Operating rate	600 cyc/h at ≤ 55 °C

Environment

IP degree of protection	IP20 front face with shrouds (ordered separately) conforming to IEC 60529 IP20 front face with shrouds (ordered separately) conforming to VDE 0106
protective treatment	TH
ambient air temperature for operation	-5...55 °C
ambient air temperature for storage	-60...80 °C
permissible ambient air temperature around the device	-5...55 °C
operating altitude	3000 m without derating
mechanical robustness	Vibrations resistance contactor open 2 Gn, 5...300 Hz Shocks resistance contactor closed 15 Gn for 11 ms Shocks resistance contactor open 6 Gn for 11 ms Vibrations resistance contactor closed 4 Gn, 5...300 Hz
height	304 mm
width	309 mm
depth	255 mm
product weight	18.75 kg

Offer Sustainability

Sustainable offer status	Green Premium product
RoHS (date code: YYWW)	Compliant - since 0843 - Schneider Electric declaration of conformity
REACH	Reference not containing SVHC above the threshold
Product environmental profile	Available
Product end of life instructions	Available

Dimensions and Drawings

LC1 F630 and F800

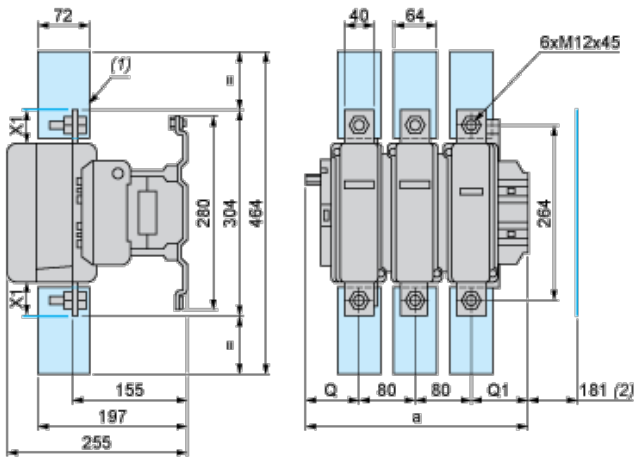

- (1) Power terminal protection shroud.
- (2) Minimum distance required for coil removal.

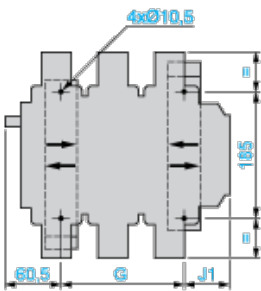

NOTE: X1 (mm) = Minimum electrical clearance according to operating voltage and breaking capacity.

LC1		a	G supplied	G min.	G max.	J1	Q	Q1
F630	2P	309	180	100	195	68.5	102	127
F630, F800	3P	309	180	100	195	68.5	60	89
F630	4P	389	240	150	275	88.5	60	89

Voltage	200...500 V	690...1000 V	200...690 V	1000 V
LC1 F630	20	30	–	–
LC1 F800	–	–	10	20

TeSys F reversing contactors and changeover contactor pairs Vertically mounted

NOTE: For customer assembly, with mechanical interlock (MI) LA9 F, fixing recommended on AM1 EC uprights (please consult your Regional Sales Office). 2 x LC1 identical or different ratings (LC1 F115 to F630 and F800).

Assembly A

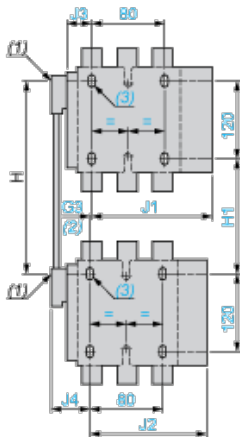

- (1) Mechanical interlock shaft.
- (2) For assembly of contactors of different ratings only.
- (3) 4 x Ø6.5 for LC1 F115 to F225.

Assembly A⁽⁷⁾ - Mechanical interlock reference

	G3 3P	G3 4P	H min.	H max.	H1 min.	H1 max.	J1 3P	J1 4P
LA9 FF4F	0	0	200	310	80	190	137	155.5
LA9 FG4F	3	4	210	300	90	180	139.5	159.5
LA9 FG4G	0	0	220	310	100	190	139.5	159.5

	J2 3P	J2 4P	J3 3P	J3 4P	J4 3P	J4 4P
LA9 FF4F	137	155.5	48.5	67	48.5	67
LA9 FG4F	137	155.5	53	73	54	69
LA9 FG4G	139.5	159.5	53	73	53	73

Assembly B

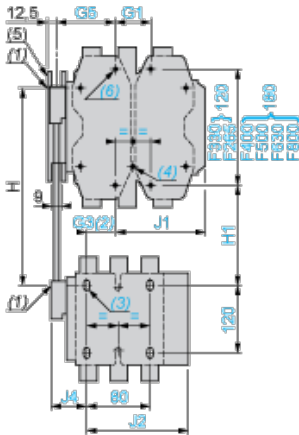

(4) 4 x Ø6.5 for LC1 F265.

(5) Mechanical interlock guide bracket.

Assembly B⁽⁷⁾ - Mechanical interlock reference

	G1 3P	G1 4P	G3 3P	G3 4P	G5 3P	G5 4P	H min.	H max.
LA9 FH4F	96	96	21	27	60	83	240	380
LA9 FJ4F	80	80	45	26	83	83	250	380
LA9 FK4F	80	140	45	26	83	83	270	380
LA9 FL4F	180	240	35	17	74	74	310	380
LA9 FH4G	96	96	19	23	60	83	250	380
LA9 FJ4G	80	80	42	22	83	83	250	380
LA9 FK4G	80	140	42	22	83	83	270	380
LA9 FL4G	180	240	33	13	74	74	310	380

	H1 min.	H1 max.	J1 3P	J1 4P	J2 3P	J2 4P	J4 3P	J4 4P
LA9 FH4F	110	250	157.5	181.5	137	155.5	48.5	67
LA9 FJ4F	80	210	144.5	192.5	137	155.5	48.5	67
LA9 FK4F	100	210	164.5	219.5	137	155.5	48.5	67
LA9 FL4F	140	210	248.5	328.5	137	155.5	48.5	67
LA9 FH4G	120	250	157.5	181.5	139.5	159.5	53	73
LA9 FJ4G	90	220	144.5	192.5	139.5	159.5	53	73
LA9 FK4G	110	220	164.5	219.5	139.5	159.5	53	73
LA9 FL4G	150	220	248.5	328.5	139.5	159.5	53	73

Assembly C

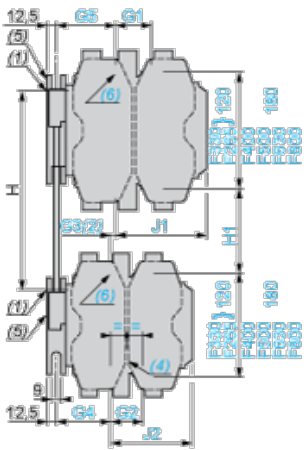

(6) 4 x Ø8.5 for LC1 F400, F500 or 4 x Ø10.5 for LC1 F630 and F800.

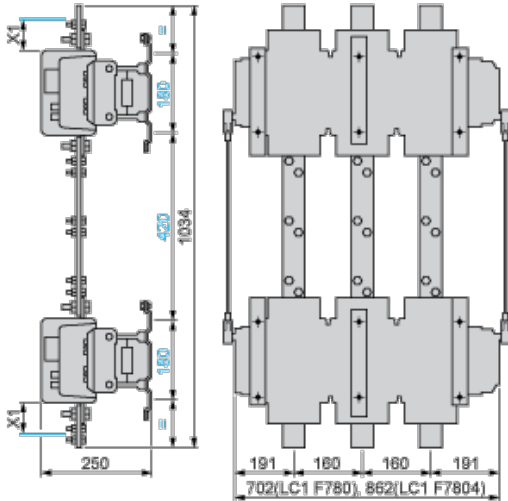

(7) Only 3P for F800.

(8) In this case, G4 is greater than G5.

Assembly C⁽⁷⁾

	G1 3P	G1 4P	G2 3P	G2 4P	G3 3P	G3 4P	G4 3P	G4 4P	G5 3P	G5 4P
LA9 FH4H	96	96	96	96	0	0	60	83	60	83
LA9 FJ4H	80	80	96	96	23	0	60	83	83	83
LA9 FK4H	80	140	96	96	23	0	60	83	83	83
LA9 FL4H	180	240	96	96	14	9 ⁽⁸⁾	60	83	74	74
LA9 FJ4J	80	80	80	80	0	0	83	83	83	83
LA9 FK4J	80	140	80	80	0	0	83	83	83	83
LA9 FL4J	180	240	80	80	9 ⁽⁸⁾	9 ⁽⁸⁾	83	83	74	74
LA9 FK4K	80	140	80	140	0	0	83	83	83	83
LA9 FL4K	180	240	80	140	9 ⁽⁸⁾	9 ⁽⁸⁾	83	83	74	74
LA9 FL4L	180	240	180	240	0	0	74	74	74	74

	H min.	H max.	H1 min.	H1 max.	J1 3P	J1 4P	J2 3P	J2 4P
LA9 FH4H	250	380	130	260	157.5	181.5	157.5	181.5
LA9 FJ4H	260	380	110	230	144.5	192.5	157.5	181.5
LA9 FK4H	280	380	130	230	164.5	219.5	157.5	181.5
LA9 FL4H	330	380	170	220	248.5	328.5	157.5	181.5
LA9 FJ4J	260	380	60	200	144.5	192.5	144.5	192.5

LA9 FK4J	280	380	100	200	164.5	219.5	144.5	192.5
LA9 FL4J	325	380	140	195	248.5	329.5	144.5	192.5
LA9 FK4K	300	380	120	200	164.5	329.5	164.5	219.5
LA9 FL4K	345	380	160	195	248.5	328.5	164.5	219.5
LA9 FL4L	380	380	200	200	248.5	328.5	248.5	328.5

Connections and Schema

2, 3, and 4-pole Contactors

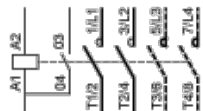

LC1 F115 to F630, F1250 (coil LX1 F \sim)



LC1 F115 to F630, F1250 (coil LX4 F $\overline{\overline{\overline{\quad}}}$)

LC1 F115 to F265 (coil LX9 F \sim)

LC1 F800 (coil LX8 F \sim / $\overline{\overline{\overline{\quad}}}$)