



Trade Audio Visual Products

**TRADE
MADE**
QUALITY MATERIALS FOR
THE TRADESMAN IN MIND

★ ★ ★ ★ ★
**100%
Australian
Owned**

Articulated TV Bracket for 17" - 37" screens

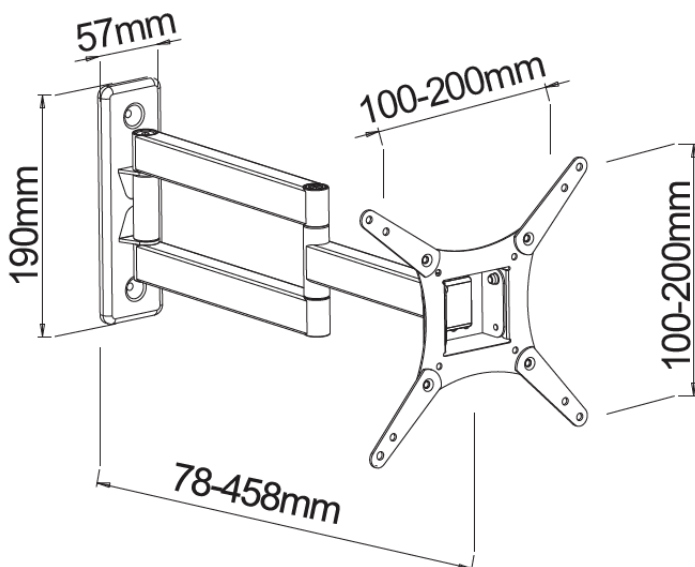

Digital Life Articulated TV Bracket for 17" to 37" Screens, can withhold up to 25kg. The bracket can fold flat to the wall with 52mm space and extends to a full 440mm with tilt and swivel. The bracket fits a variety of mounting patterns from VESA 75x75 and VESA 100x100 and comes complete with VESA 200x200 adaptor arms for 200x200 or 200x100 fittings.

Product Code: DLS2

- For 17" to 37" screens
- Max VESA: 200mm x 200mm
- Max Weight: 25kg
- Tilt: -15° to +15°

Available Colours



Black