

**Arteor™**  
**Wood plates for Italian and US standard**

Cat. No(s): 575 245/255/265/275/285/295 - 575 305/325  
575 635/645/655/665/675 - 576 419/429/439/449/459/469  
576 619/629/639/649/659/669/679 - 576 725/739

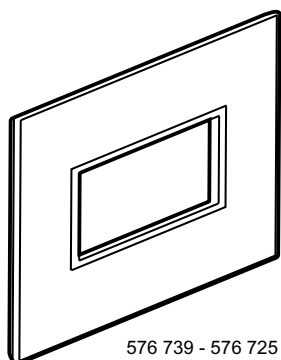

576 739 - 576 725

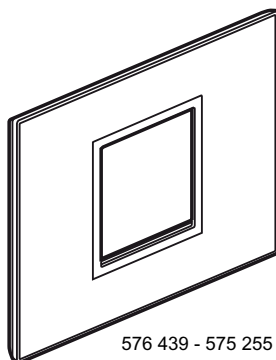

576 439 - 575 255

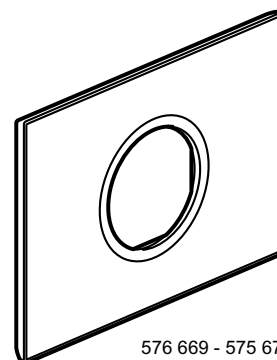



576 669 - 575 675

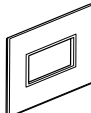
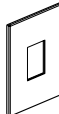
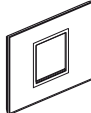
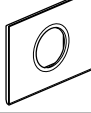
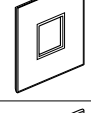
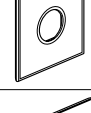

**1. USE**

Plates for covering mechanisms.

**2. RANGE**

	Designation	Finishes		Number of modules	Fixing method	Weight (g)
		Light oak	Wenge style			
	1 module plate (2'' x 4'')	576 419	575 245	1	With clips	130
	1 module plate vertical (2'' x 4'')	576 739	576 725	1	with clips	130
	2 modules plate square (2'' x 4'')	575 439	575 255	2	With clips	125
	2 modules plate round (2'' x 4'')	576 429	575 635	2	With clips	129
	2 modules plate square (4'' x 4'')	576 629	575 265	2	With clips	150
	2 modules plate round (4'' x 4'')	576 619	575 645	2	With clips	154
	3 modules plate square (2'' x 4'')	576 459	575 275	3	With clips	120
	3 modules plate round (2'' x 4'')	576 449	575 655	3	With clips	120

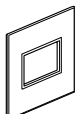
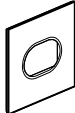
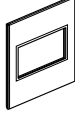
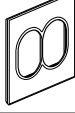
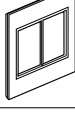
**2. RANGE** (suite)

	Designation	Finishes		Number of modules	Fixing method	Weight (g)
		Light oak	Wenge style			
	3 modules plate square (4" x 4")	576 649	575 285	3	with clips	151
	3 modules plate round (4" x 4")	576 639	575 665	3	with clips	145
	4 modules plate square (4" x 4")	576 659	575 295	4	with clips	99
	2 x 3 modules plate round (4" x 4")	576 669	575 675	2 x 3	with clips	126
	2 x 3 modules plate square (4" x 4")	576 679	575 305	2 x 3	with clips	115
	Plate for 4 modules socket (2" x 4")	576 469	575 325	4	with clips	141

**3. OVERALL DIMENSIONS**

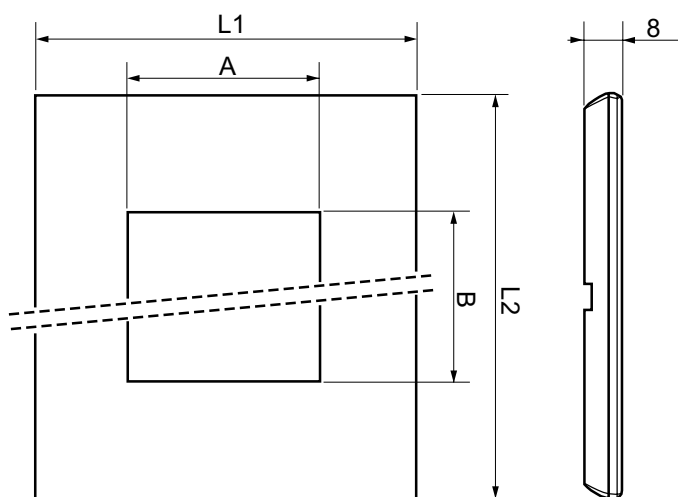

Cat. No.	L1	L2	A	B	
575 245 - 576 419	127	92	22.8	45.4	
575 255 - 576 439		127	45.4		
575 265 - 576 629		92	68		
575 275 - 576 459		127	90		
575 285 - 576 649		127	2 x 45.4		2 x 68
575 295 - 576 659		92	45.4		90.8
575 305 - 576 679		92	92		Ø 45.4
575 635 - 576 429	127	127	Ø 45.4		
575 645 - 576 619		92	68	45.4	
575 655 - 576 449		127	2 x 45.4	2 x 68	
575 665 - 576 639		127	22.8	45.4	
575 675 - 576 669		92	92	Ø 45.4	
576 725 - 576 739		92	92	Ø 45.4	

**4. MOUNTING**

The plates clip on in notches onto screw-type or claw-type mounting supports (notches are used for thickness compensation. E.g.: wall paper).  
Easy to remove with a screwdriver.

No flatness defect of more than 1.5 mm in a periphery of 10 cm around the installed flush box.

Protection film must be removed only once site work is fully completed.

**5. TECHNICAL CHARACTERISTICS****5.1 Mechanical characteristics**

Impact tests: IK 04

**5.2 Material characteristics**

Front plate: wood

Under plate: polycarbonate

Surround: chromed zamac

**5.3 Climatic characteristics**

Storage temperatures: - 10° C to + 70° C

Operating temperatures: - 5° C to + 50° C

**6. CLEANING**

Surface cleaning with a cloth.

Do not use: acetone, tar remover, trichloroethylene.

**Resistance to cleaning agents**

Hexane (EN 60669-1), methylated spirits, soapy water, glass cleaning substance.

**7. SPECIAL USE**

Arteor plates must not be painted.