

Catalogue No: 1492-WFB4

SCREW TERMINAL FUSE 4mm 1 CONDUCTOR 15A

Termination and Wiring Systems > Terminals and Pre-Wired Cables > Terminals - Screw > Allen-Bradley Terminal Blocks > Fuse Terminals



Fuse Terminal 4mm Black Non-Indicating



- Tin-plated terminals and steel screws for corrosion resistance (Bulletin 1492-W terminal blocks have nickel-plated terminals and stainless steel screws)
- High copper content copper alloy for excellent conductivity
- Four-sided wire funnel guides for easy wire insertion
- Finger-safe housings to prevent accidental contact with live circuits
- International approvals for worldwide use
- DIN Rail mountable, allowing terminal blocks to be placed on the same channel as contactors, starters, relays, and other DIN Rail-mounted control devices
- Self-extinguishing, polyamide 6.6 housing material with UL 94-V0 flammability rating

Representative Photo Only
(actual product may vary based on configuration selections)

SPECIFICATIONS

Product Series	zz1492
Component Type Termination Wiring	Terminal
Package Quantity	50 qty
Colour, Body / Housing	Black colour
Wire / Conductor Size (Min)	0.5 mm ² min
Wire / Conductor Size (Max)	4 mm ²
Wire Strip Length	8 mm
Tightening Torque, Min	0.3 Nm
Tightening Torque, Max	0.6 Nm
In, Rated Current	6.3 A
Un, Nominal Voltage	500 V
Fuse Supplied	No Y/N
Fuse Cartridge Size	5 x 20mm size
Height	50.7 mm
Width	8 mm
Depth	39.4 mm
Insulation Temperature (Min)	-40 °C
Insulation Temperature (Max)	90 °C

Catalogue No: **1492-WFB4**

SCREW TERMINAL FUSE 4mm 1 CONDUCTOR 15A

Termination and Wiring Systems > Terminals and Pre-Wired Cables > Terminals - Screw > Allen-Bradley Terminal Blocks > Fuse Terminals



REFERENCES	
IECEX Certificate	-
Supplier Declaration of Conformity:	-
Installation Guide:	-
User Manual:	-
Manufacturer Datasheet:	-
Manufacturer Catalogue & Product Selection:	-

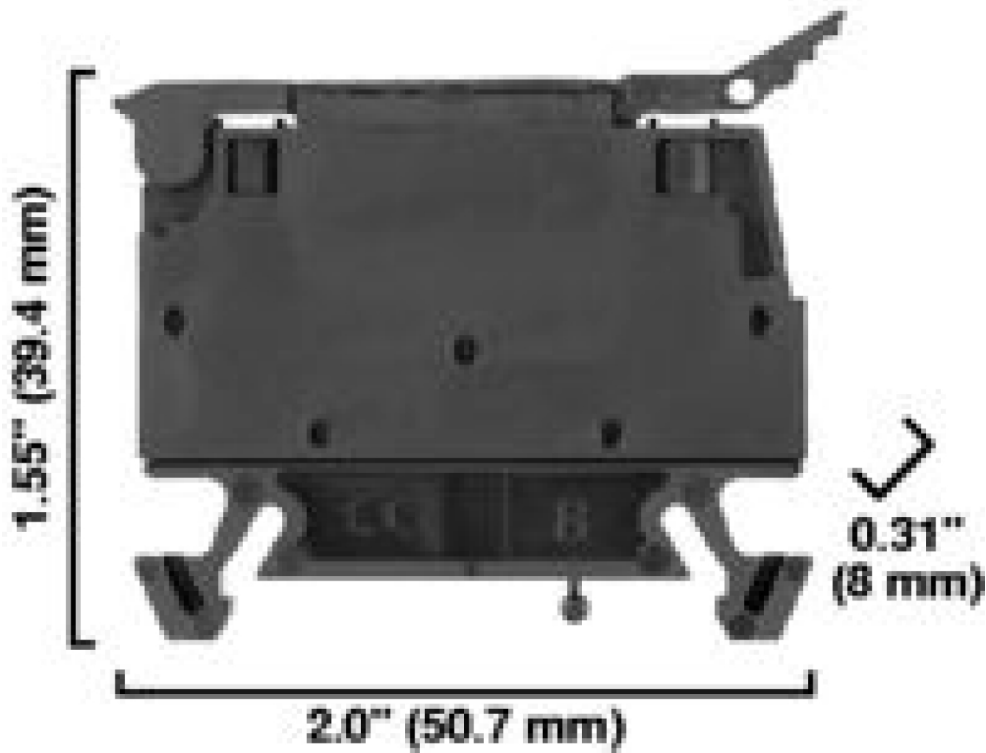

Dimension Diagram