

Catalogue No: **800FP-SM22PX10**

SEL SW 22.5mm PLASTIC 2P KNOB MAIN 1NO BLACK

Operator Control Devices > Pushbuttons and Control Switches > Pushbuttons and Pilot Lights > Allen-Bradley 800F Pushbuttons and Pilot Lights > 800F Selector Switches > Selector Switches (Fully Assembled Units)



2 POSITION SELECTOR SWITCH MAINTAINED C/W 1 N/O CONTACT

- The 800F range of 22.5mm operator control devices includes a diverse range of products making it suitable for use in a wide range of applications. Products in the range include pushbuttons, selector switches, pilot lights, emergency stop operators and more.
- Operators are available in both plastic (800FP) and metal (800FM) variants.

Representative Photo Only
(actual product may vary based on configuration selections)

SPECIFICATIONS

Product Series	800FP
Component Type Pushbutton and Pilot Lights	Selector Switch
Operator Type	Selector Switch, Knob, 2-Position type
Operator Positions (from Vertical)	30° -30°
Key	No Y / N
Operator Action, Left	Latched / Maintained
Operator Action, Right	Latched / Maintained
Colour, Operator	Black colour
Material, Operator	TP (Thermoplastic) material
Colour, Operator Insert	White
Material, Bezel	Glass-Filled Nylon / PA6 / PA66 (Polyamide 6)
Coupling Plate Included	Yes Y / N
Material, Coupling Plate	Glass-Filled Nylon / PA6 / PA66 (Polyamide 6)
Mounting	22.5mm Mounting
Contact Block Included	Yes
Contact Configuration	1 NO
Ui, Rated Insulation Voltage	690 V (rms)
Terminal Type	Screw Terminal(s)
Material, Terminal	Brass
Tightening Torque, Min	0.7 Nm
Tightening Torque, Max	0.9 Nm
Operating Force	3.4 N
Wire / Conductor Size (Min)	0.75 mm ² min
Wire / Conductor Size (Max)	12 AWG (3.31 mm ²)
Dielectric Strength	2.5kV for 1 minute V AC
Fuse Characteristic Type(s)	gL/gG
Tightening Torque, Nominal	1.7 Nm

Catalogue No: **800FP-SM22PX10**
SEL SW 22.5mm PLASTIC 2P KNOB MAIN 1NO BLACK

Operator Control Devices > Pushbuttons and Control Switches > Pushbuttons and Pilot Lights > Allen-Bradley 800F Pushbuttons and Pilot Lights > 800F Selector Switches > Selector Switches (Fully Assembled Units)



Mechanical Service Life	1000000 cycles
RoHS Approved	Yes
CE Marked	Yes
Operating Temperature, Max	70 °C max
Operating Temperature, Min	-25 °C min
Storage Temperature, Max	85 °C max
Storage Temperature, Min	-40 °C min
Relative Humidity, Min	50 %RH
Relative Humidity, Max	95 %RH
IP Rating	IP66 IP65
Shock Acceleration (Max.)	100 g
Shock Duration (Max.)	11 ms
Vibration Acceleration (Max.)	10 m/s ²
Vibration Displacement (Peak to Peak Max.)	1.52 mm
Vibration Frequency, Operational (Max.)	2000 Hz
Vibration Duration (Max.)	180 min
Standards Compliance	NEMA ICS-5 UL 508 EN 60947-1 EN 60947-5-1 EN 60947-5-5 IEC 60947-1 ISO 13850
Certifications	UR UL CSA CCC CE RoHS
Shipping Approvals	ABS (American Bureau of Shipping)

REFERENCES

IECEX Certificate	-
Supplier Declaration of Conformity:	-
Installation Guide:	-
User Manual:	-
Manufacturer Datasheet:	800FPSM22PX10_Manufacturer Datasheet
Manufacturer Catalogue & Product Selection:	800FPSM22PX10_Manufacturer Product Selection Guide

Catalogue No: **800FP-SM22PX10**

SEL SW 22.5mm PLASTIC 2P KNOB MAIN 1NO BLACK

Operator Control Devices > Pushbuttons and Control Switches > Pushbuttons and Pilot Lights > Allen-Bradley 800F
Pushbuttons and Pilot Lights > 800F Selector Switches > Selector Switches (Fully Assembled Units)



Illuminated and Non-Illuminated Knob Selector Switch Operators

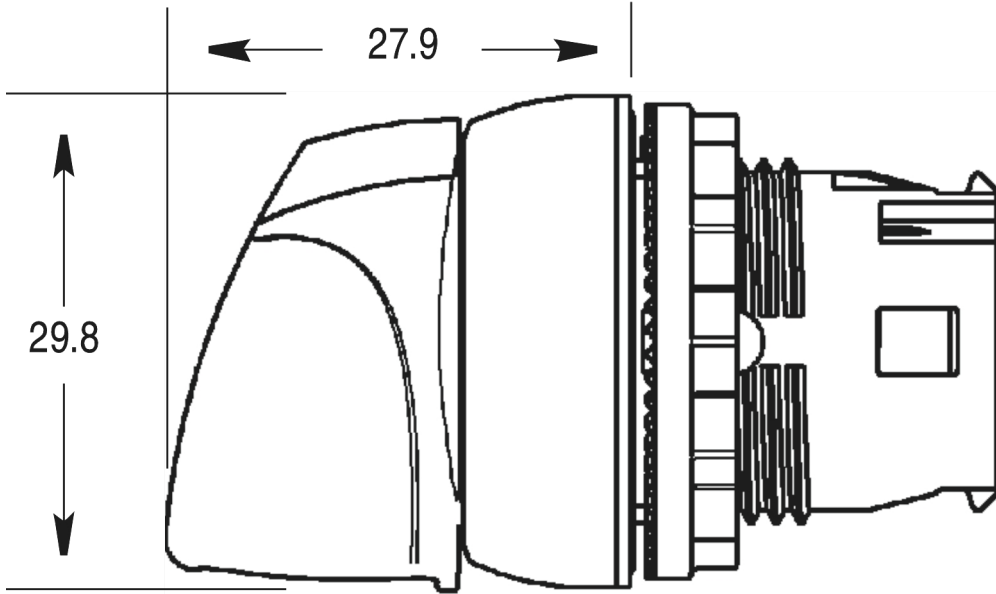

Dimension Diagram