

# Catalogue No: **800FP-KM23**

## KEY SEL SW 22.5mm PLASTIC 2P MAIN AKR CODE 3825

Operator Control Devices > Pushbuttons and Control Switches > Pushbuttons and Pilot Lights > Allen-Bradley 800F Pushbuttons and Pilot Lights > 800F Selector Switches > 2-Position, Keyed Selector Switches (Components Only)



### KEY SELECTOR SWITCH 22.5mm PLASTIC 2 POSITION AKR 3825



- The 800F range of 22.5mm operator control devices includes a diverse range of products making it suitable for use in a wide range of applications. Products in the range include pushbuttons, selector switches, pilot lights, emergency stop operators and more.
- Operators are available in both plastic (800FP) and metal (800FM) variants.

Representative Photo Only  
(actual product may vary based on configuration selections)

#### SPECIFICATIONS

	800FP
Component Type Pushbutton and Pilot Lights	Selector Switch
Operator Type	Selector Switch, Key, 2-Position type
Operator Positions (from Vertical)	30° -30°
Key Removal Position(s)	Left / Right
Key Code	3825 (standard)
Operator Action, Left	Latched / Maintained
Operator Action, Right	Latched / Maintained
Colour, Operator	Black colour
Material, Operator	TP (Thermoplastic) material
Colour, Operator Insert	White
	Glass-Filled Nylon / PA6 / PA66 (Polyamide 6)
Coupling Plate Included	No Y / N
Mounting	22.5mm Mounting
Contact Block Included	No
Tightening Torque, Nominal	1.7 Nm
Mechanical Service Life	1000000 cycles
RoHS Approved	Yes
CE Marked	Yes
Operating Temperature, Max	70 °C max
Operating Temperature, Min	-25 °C min
Storage Temperature, Max	85 °C max
Storage Temperature, Min	-40 °C min
Relative Humidity, Min	50 %RH
Relative Humidity, Max	95 %RH
IP Rating	IP66 IP65
Shock Acceleration (Max.)	100 g

# Catalogue No: **800FP-KM23**

## KEY SEL SW 22.5mm PLASTIC 2P MAIN AKR CODE 3825

Operator Control Devices > Pushbuttons and Control Switches > Pushbuttons and Pilot Lights > Allen-Bradley 800F Pushbuttons and Pilot Lights > 800F Selector Switches > 2-Position, Keyed Selector Switches (Components Only)



Shock Duration (Max.)	11 ms
Vibration Acceleration (Max.)	10 m/s <sup>2</sup>
Vibration Displacement (Peak to Peak Max.)	1.52 mm
Vibration Frequency, Operational (Max.)	2000 Hz
Vibration Duration (Max.)	180 min
Standards Compliance	NEMA ICS-5 UL 508 EN 60947-1 EN 60947-5-1 EN 60947-5-5 IEC 60947-1 ISO 13850
Certifications	UR UL CSA CCC CE RoHS
Shipping Approvals	ABS (American Bureau of Shipping)

### REFERENCES

IECEX Certificate	-
Supplier Declaration of Conformity:	-
Installation Guide:	-
User Manual:	-
Manufacturer Datasheet:	<a href="#">800FPKM23_Manufacturer Datasheet</a>
Manufacturer Catalogue & Product Selection:	<a href="#">800FPKM23_Manufacturer Product Selection Guide</a>

# Key Selector Switch and Key Ejected SensEject Operators

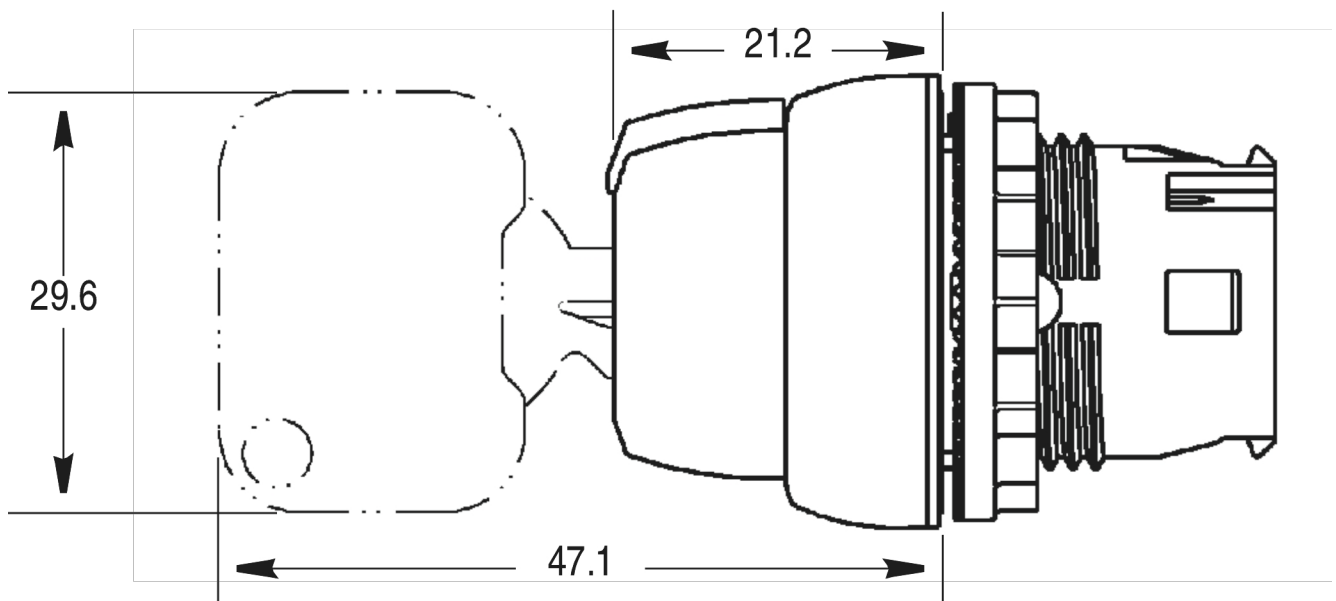

Catalogue No: **800FP-KM23**

**KEY SEL SW 22.5mm PLASTIC 2P MAIN AKR CODE 3825**

Operator Control Devices > Pushbuttons and Control Switches > Pushbuttons and Pilot Lights > Allen-Bradley 800F  
Pushbuttons and Pilot Lights > 800F Selector Switches > 2-Position, Keyed Selector Switches (Components Only)



Dimension Diagram