

Catalogue No: **800FP-F301**

PB 22.5mm PLASTIC MOM FLUSH HD N/ILL GREEN START

Operator Control Devices > Pushbuttons and Control Switches > Pushbuttons and Pilot Lights > Allen-Bradley 800F Pushbuttons and Pilot Lights > 800F Pushbuttons > 800F Flush Momentary Pushbuttons



Representative Photo Only
(actual product may vary based on configuration selections)

PUSHBUTTON FLUSH GREEN START

- The 800F line of 22.5 mm push buttons is designed and manufactured to demanding performance specifications to ensure you receive optimized durability and performance.
- 800FP operators are made of industrial grade thermoplastic for superior chemical resistance.
- 800FM operators are constructed of tough die cast zinc alloy, finished with chromate plating that can be used in the most arduous applications.

SPECIFICATIONS

Product Series	800FP
Component Type Pushbutton and Pilot Lights	Pushbutton
Operator Type	Pushbutton, Flush type
Operator Action	Momentary action
Diameter, Operator	29.6 mm
Colour, Operator	Green colour
Material, Operator	TP (Thermoplastic) material
Text, Operator	START
Operator Insert Type	Green 'START' insert
Material, Bezel	Glass-Filled Nylon / PA6 / PA66 (Polyamide 6)
Coupling Plate Included	No Y / N
Diameter, Mounting Hole(s)	22.5 mm
Contact Block Included	No
Illuminated	No Y / N
Tightening Torque, Nominal	1.7 Nm
Mechanical Service Life	10000000 cycles
RoHS Approved	Yes
CE Marked	Yes
Operating Temperature, Max	70 °C max
Operating Temperature, Min	-25 °C min
Storage Temperature, Max	85 °C max
Storage Temperature, Min	-40 °C min
Relative humidity, min	50 %RH
Relative Humidity, Max	95 %RH
IP Rating	IP66 IP65
Shock Acceleration (Max.)	100 g
Shock Duration (Max.)	11 ms

Catalogue No: **800FP-F301**

PB 22.5mm PLASTIC MOM FLUSH HD N/ILL GREEN START

Operator Control Devices > Pushbuttons and Control Switches > Pushbuttons and Pilot Lights > Allen-Bradley 800F Pushbuttons and Pilot Lights > 800F Pushbuttons > 800F Flush Momentary Pushbuttons



Vibration Acceleration (Max.)	10 m/s ²
Vibration Displacement (Peak to Peak Max.)	1.52 mm
Vibration Frequency, Operational (Max.)	2000 Hz
Vibration Duration (Max.)	180 min
Standards Compliance	NEMA ICS-5 UL 508 EN 60947-1 EN 60947-5-1 EN 60947-5-5 IEC 60947-1 ISO 13850
Certifications	UR UL CSA CCC CE RoHS
Shipping Approvals	ABS (American Bureau of Shipping)

REFERENCES	
IECEX Certificate	-
Supplier Declaration of Conformity:	-
Installation Guide:	-
User Manual:	-
Manufacturer Datasheet:	800FPF301_Manufacturer Datasheet
Manufacturer Catalogue & Product Selection:	800FPF301_Manufacturer Product Selection Guide

Non-Illuminated and Illuminated Momentary Flush Push Button Operators

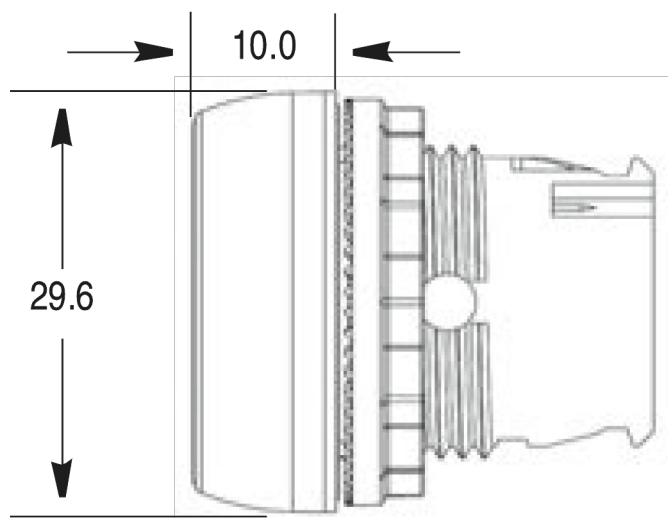

Dimension Diagram

Catalogue No: **800FP-F301**

PB 22.5mm PLASTIC MOM FLUSH HD N/ILL GREEN START

Operator Control Devices > Pushbuttons and Control Switches > Pushbuttons and Pilot Lights > Allen-Bradley 800F
Pushbuttons and Pilot Lights > 800F Pushbuttons > 800F Flush Momentary Pushbuttons

