

# Catalogue No: **800FM-P5**

## PL 22.5mm METAL YELLOW

Operator Control Devices > Pushbuttons and Control Switches > Pushbuttons and Pilot Lights > Allen-Bradley 800F Pushbuttons and Pilot Lights > 800F Pilot Lights > 800F Pilot Light (Components Only)



### PILOT LIGHT YELLOW



- The 800F range of 22.5mm operator control devices includes a diverse range of products making it suitable for use in a wide range of applications. Products in the range include pushbuttons, selector switches, pilot lights, emergency stop operators and more.
- Operators are available in both plastic (800FP) and metal (800FM) variants.

Representative Photo Only  
(actual product may vary based on configuration selections)

#### SPECIFICATIONS

Product Series	800FM
Component Type Pushbutton and Pilot Lights	Pilot Light
Diameter, lens	29.6 mm
Colour, Lens	Yellow colour
Material, Lens	Polyamide
Material, Bezel	Zinc
Material, Body / Housing	Zinc Alloy, Die-Cast, Chrome-Plated material
Tightening Torque, Nominal	4.4 Nm
Wire / Conductor Size (Min)	0.75 mm <sup>2</sup> min
Lamp Module Included	No
Mounting	22.5mm Mounting
Dielectric Strength	2.5kV for 1 minute V AC
RoHS Approved	Yes
CE Marked	Yes
Operating Temperature, Max	70 °C max
Operating Temperature, Min	-25 °C min
Storage Temperature, Max	85 °C max
Storage Temperature, Min	-40 °C min
Relative Humidity, Min	50 %RH
Relative Humidity, Max	95 %RH
IP Rating	IP66
Shock Acceleration (Max.)	100 g
Shock Duration (Max.)	11 ms
Vibration Acceleration (Max.)	10 m/s <sup>2</sup>
Vibration Displacement (Peak to Peak Max.)	1.52 mm
Vibration Frequency, Operational (Max.)	2000 Hz
Vibration Duration (Max.)	180 min

# Catalogue No: **800FM-P5**

## PL 22.5mm METAL YELLOW

Operator Control Devices > Pushbuttons and Control Switches > Pushbuttons and Pilot Lights > Allen-Bradley 800F Pushbuttons and Pilot Lights > 800F Pilot Lights > 800F Pilot Light (Components Only)



Standards Compliance	NEMA ICS-5 UL 508 EN 60947-1 EN 60947-5-1 EN 60947-5-5 IEC 60947-1 ISO 13850
----------------------	--

Certifications	UR UL CSA CCC CE RoHS
----------------	--------------------------------------

Shipping Approvals	ABS (American Bureau of Shipping)
--------------------	-----------------------------------

### REFERENCES

IECEX Certificate	-
-------------------	---

Supplier Declaration of Conformity:	-
-------------------------------------	---

Installation Guide:	-
---------------------	---

User Manual:	-
--------------	---

Manufacturer Datasheet:	<a href="#">800FMP5_Manufacturer Datasheet</a>
-------------------------	--

Manufacturer Catalogue & Product Selection:	<a href="#">800FMP5_Manufacturer Product Selection Guide</a>
---	--

# Pilot Light Operators

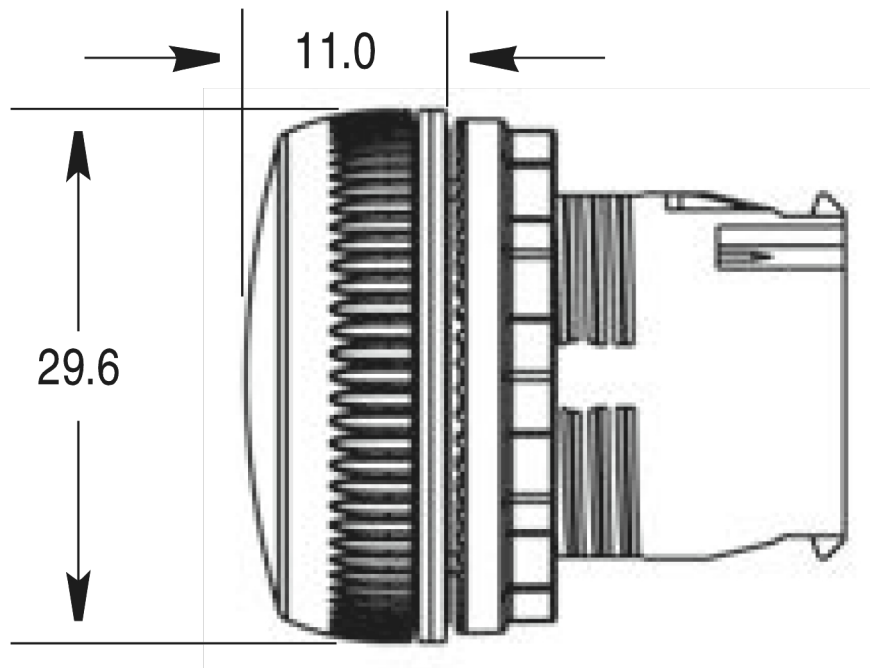

Dimension Diagram