

Motor Protection Circuit Breakers

Product Overview

2



Bulletin 140M Motor Protection Circuit Breakers

- Current Range 0.1...630 A
- UL Listed for Motor Loads
 - Short Circuit Protection
 - Overload Protection
- Visible Trip Indication
- High Current Limiting
- High Switching Capacity

The Bulletin 140M Motor Protection Circuit Breakers provide short circuit and overload protection for individual motor loads. Factory-installed internal accessories make installation and wiring easy.

Table of Contents

Product Selection —
 Motor Protection
 Circuit Breakers..... 2-8
 Approximate
 Dimensions..... 2-51

Standards Compliance

IEC/EN 60947-1, -2, -4-1, -5-1
 IEC/EN 60204-1
 CSA, C22.2 No.14
 UL 508
 UL 489 (I-, J-, L-Frame)

Certifications

CE Marked
 cULus Listed (File No.
 E54612, NLRV(7); E205542,
 NKJH(7); E197878, DIVQ(7);)
 CCC
 CSA Certified
 ATEX

General Information

Motor Protection Circuit Breakers may provide the following protective and control functions.

- Disconnect for Motor Branch Circuit
- Branch-Circuit, Short-Circuit Protection (Magnetic Protection)
- Overload Protection (Thermal Protection)
- Switching (Manual)

In North America, electrical codes require that an individual Motor Branch Circuit be protected by a UL/CSA Listed Fuse, Circuit Breaker or Self-Protected Combination Motor Controller.

140M-C, D and F Frames:

The 140M-C, D and F frame Motor Protection Circuit Breakers may have 2 cULus Listings – as Manual, Self-Protected Combination Motor Controllers and as Manual Motor Controllers (with optional approvals for Motor Disconnect and Group Installation).

When UL/CSA listed as Manual, Self-Protected Combination Motor Controllers, the 140M Motor Protection Circuit Breakers provide all of the necessary NEC/CEC requirements for the protection and control of individual Motor Branch Circuits without additional protective devices.

At some higher voltages and currents (particularly at 600V), a few of the 140M-C, D and F frame devices are only UL/CSA Listed as Manual Motor Controllers (with optional approvals for Motor Disconnect and Group Installation). In NEC/CEC Group Installations, these devices must be applied per the appropriate rules which require the use of an upstream Branch-Circuit, Short-Circuit Protective Device (BCPD). See the table on page 2-18 for the specific ratings of each Motor Protection Circuit Breaker.

140-CMN Frame:

The 140-CMN frame Motor Protection Circuit Breakers are UL Listed/CSA Certified as Manual Motor Controllers (with optional approvals for Motor Disconnect and Group Installation). In NEC/CEC Group Installations, these devices must be applied per the appropriate rules which require the use of an upstream Branch-Circuit, Short-Circuit Protective Device (BCPD). See the table on page 2-18 for the specific ratings of each Motor Protection Circuit Breaker.

140M-I, J and L Frames:

The 140M-I, J and L frame Motor Protection Circuit Breakers are cULus Listed as Circuit Breakers as shown in the table on page 2-9. In these cases, the 140M Motor Protection Circuit Breakers provide all of the necessary NEC/CEC requirements for the protection and control of individual Motor Branch Circuits without additional protective devices.

For further details on the proper application of Motor Protection Circuit Breakers, please see the diagrams on the following pages.





	C-Frame	D-Frame	F-Frame	CMN-Frame	I-Frame	J-Frame	L-Frame
Max. Current I_e	32 A	32 A	45 A	90 A	205 A	250 A	630 A
Current Rating	0.1...32 A	1.6...32 A	6.3...45 A	16...90 A	40...205 A	20...250 A	100...630 A
Short Circuit Protection	✓	✓	✓	✓	✓	✓	✓
Standard Magnetic Trip	✓	✓	✓	✓	✓	✓	✓
High Magnetic Trip	✓	✓	✓	✓	—	—	—
Magnetic Only Trip (MCP)	✓	✓	✓	—	—	✓	✓
Overload Protection	✓	✓	✓	✓	✓	✓	✓
Trip Class	10	10	10	10	5...20	10...30	10...30
Standards Compliance:							
CSA 22.2, No. 14	✓	✓	✓	✓	✓	✓	✓
CSA 22.2, No. 5	—	—	—	—	✓	✓	✓
UL 508 (Group Install.)	✓ (see ratings)	✓ (see ratings)	✓ (see ratings)	✓ (see ratings)	—	—	—
UL 508 Manual, Self Protected (Type E)	✓ (see ratings)	✓ (see ratings)	✓ (see ratings)	—	—	—	—
UL 508 (Overload Protection)	✓	✓	✓	✓	✓	✓	✓
UL 489	—	—	—	—	✓	✓	✓
IEC 60947-1, -2	✓	✓	✓	✓	✓	✓	✓
IEC 60947-4-1	✓	✓	✓	—	✓	✓	✓
CE	✓	✓	✓	✓	✓	✓	✓
ATEX (IEC 60079-14)	✓ (up to 25 A)	✓ (up to 25 A)	—	—	—	—	—
CCC	✓ (up to 25 A)	✓ (up to 25 A)	✓	—	—	—	—
Accessories							
Ext. Rotary Operator	✓	✓	✓	✓	✓	✓	✓
Flex Cable Operator	—	—	—	—	✓	✓	✓
Auxiliary Contacts	✓	✓	✓	✓	✓	✓	✓
Trip Indication Contacts	✓	✓	✓	✓	✓	✓	✓

Motor Protection Circuit Breakers

Catalog Number Explanation

Cat. No. Explanation

Examples given in this section are for reference purposes. This basic explanation should not be used for product selection; not all combinations will produce a valid catalog number.

140M - **C** - **2** - **E** - **A63** - **KN** - **CC** - **GJ**
a *b* *c* *d* *e* *f* *g* *h*

2

a

Bulletin Number	
Code	Description
140M	Motor Protection Circuit Breakers (MPCBs)

c

Interrupting Rating / Breaking Capacity	
Code	Description
2	Normal Break
8	High Break

f, g, h

Factory-Installed Options

f

Miscellaneous See page 2-36

b

Frame Size and Rating	
Code	Description
C	32 A
D	32 A
F	45 A
I	205 A
J	250 A
L	400 A and 600 A

d

Protection Type	
Code	Description
E	Adj Thermal/ Fixed Mag (13...14 x I_n)
T	Adj Thermal / Fixed Mag (16...20 x I_n)

g

Aux/Trip Contacts See page 2-36

h

UV and Shunt Trips See page 2-36

e

Current Range		
Code	Description	Example
A	A = .10	A16 = 0.16
B	B = 1.0	B16 = 1.6
C	C = 10	C16 = 16
D	D = 100	D16 = 160
E	E = 1000	E16 = 1600



Group Installation with MPCBs

There is only one Branch Circuit Protective Device (BCPD) for the “Group”

Group installation has been successfully used for many years in the U.S. and Canada. It allows “two or motors or one or more motors and other loads to be connected to the same branch-circuit...”. The most restrictive part of the conditions specified for Group Installation is the requirement for the protection of the conductors for each motor circuit. In the U.S. NEC for 2002, a new rule for the conductor sizing was added for devices that are listed and marked “Suitable for use as Tap Conductor Protection”. Below is an example that illustrates installations involving multiple motors with a single BCPD protecting the entire “Group”.

Bulletin 140M Motor Protection Circuit Breakers UL/CSA Listed for Group Installation

Conductors from the BCPD to each motor must be a minimum of 1/3 the ampacity of the Branch Circuit conductors.

Bulletin 140M Motor Protection Circuit Breakers UL/CSA Listed for Tap conductor Protection in Group Installations

Conductors from the BCPD to manual motor controller listed as “...Tap Conductor Protection...” must be minimum of 1/10 the rating or setting of the BCPD. Conductors from the controller to the motor must be 125% of the motor FLA.

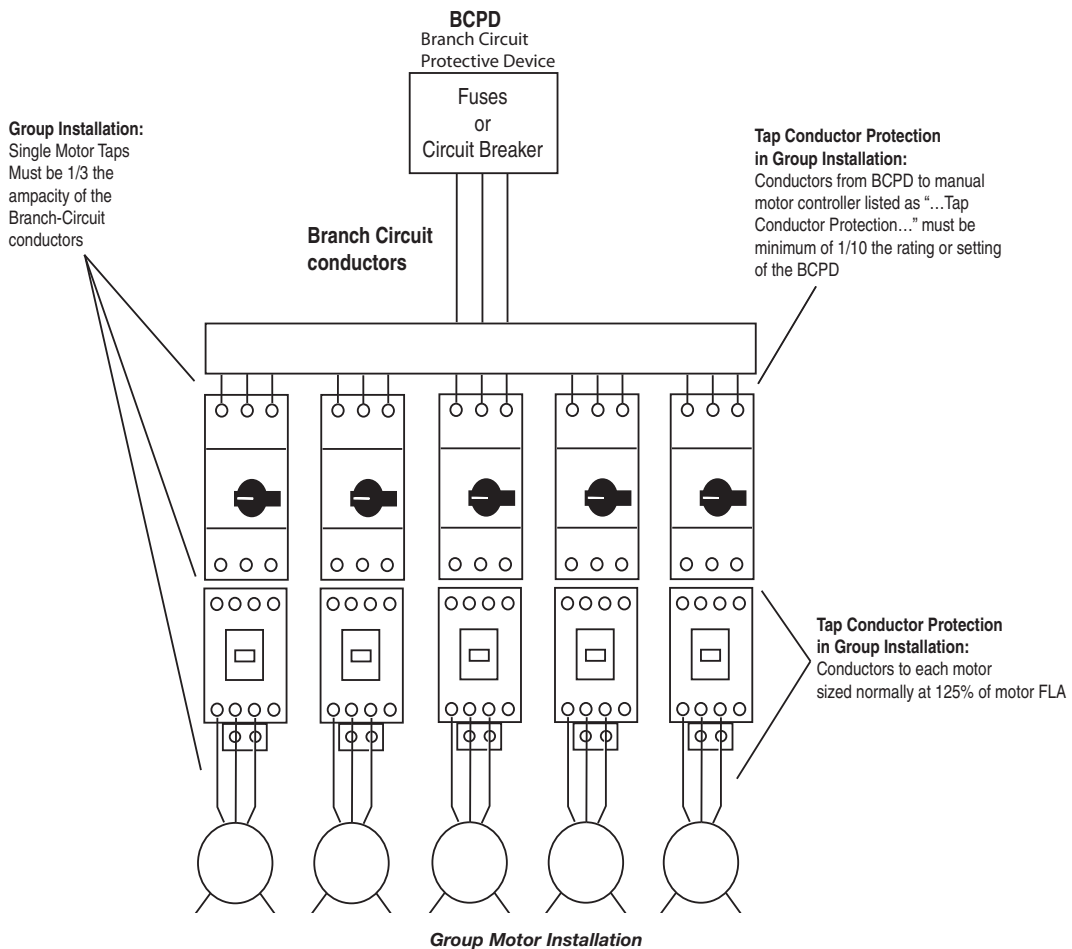

Multiple Motor Installation with MPCBs

Each Motor has an Individual Branch Circuit Protective Device

Bulletin 140M Motor Protection Circuit Breakers (MPCBs) UL/CSA Listed as Type E Manual Self-Protected Combination Motor Controllers or UL/CSA Listed as Circuit Breakers

These UL/CSA Listings allow the Bulletin 140M MPCBs to provide the branch-circuit, short-circuit protection (as well as overload protection) for each individual motor circuit. Additional short-circuit protection is not required for the protection of the individual motor circuits, leaving only the requirement for protection of the feeder circuit conductors by an upstream protective device. Below is an example that illustrates installations involving multiple motors, each with its own branch-circuit protection (BCPD).

2

Bulletin 140M-J...L (Inverse Time Circuit Breakers)

may provide the branch-circuit protection for each individual motor circuit

Bulletin 140M-C...F (Type E Self-Protected Combination Motor Controllers)

may provide the branch-circuit protection for each individual motor circuit

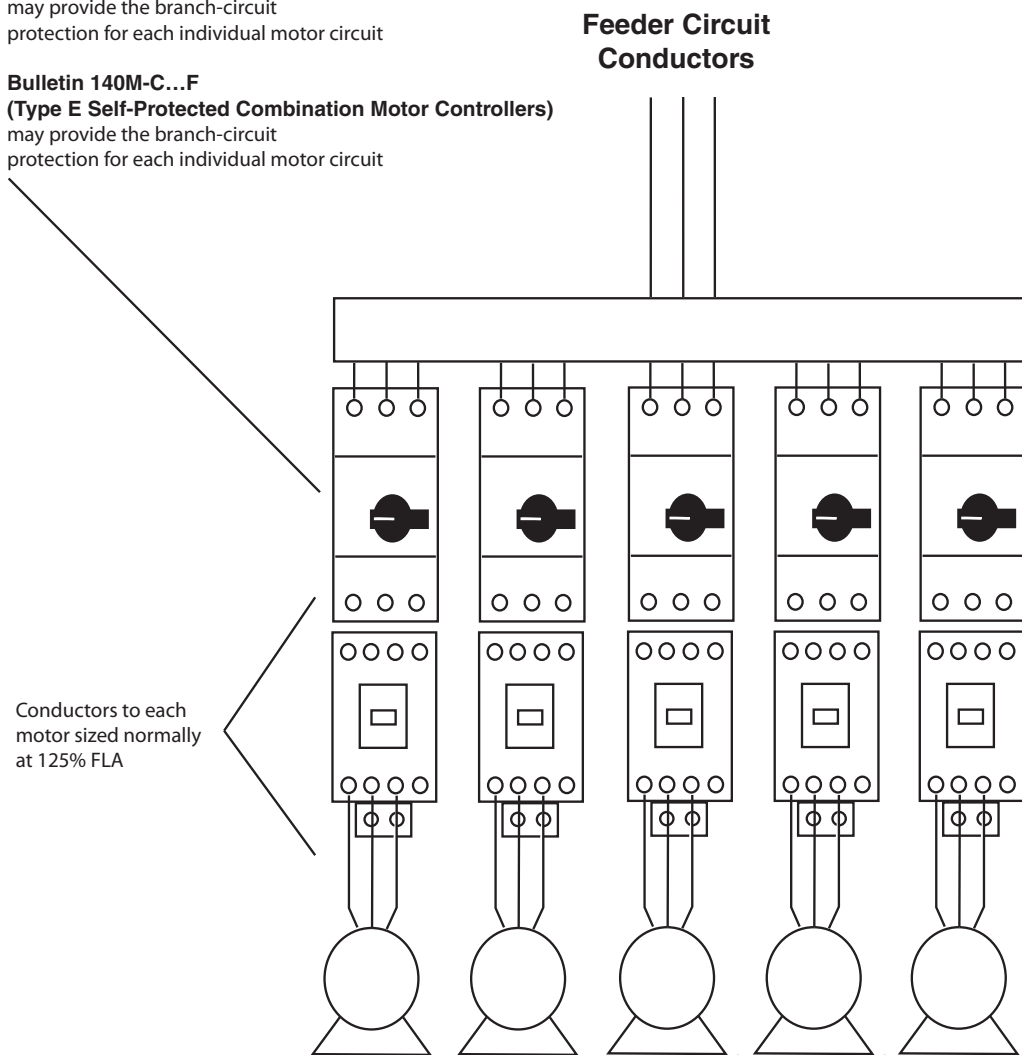

Type E and Type F Combination Motor Controllers

Most of the 140M-C...F motor protection circuit breakers are UL listed as a manual Type E self-protected combination motor controller. Although there are many tests involved, one of the critical tests a self-protected combination motor controller must pass, is to perform 6000 electrical ops. and an additional 4000 mechanical ops. after a short circuit.

By definition, a **Type F** combination motor controller consists of a Type E manual self protected combination motor controller and a magnetic or solid-state motor controller (such as a Bulletin 100-C contactor or an SMC). As with a manual Type E self-protected combination motor controller, additional short-circuit protection is not required for the individual motor circuits.

A combination of a Bulletin 140M manual self protected combination motor controller and 100-C contactor can be listed as a **Type E** self-protected combination motor controller. In this case, both the 140M and 100-C must pass the additional 6000 electrical and 4000 mechanical operational test. In some cases, this may require over sizing of the Bulletin 140M MPCB or the 100-C contactor to achieve weld free performance and meet the additional life requirements.

Motor Protection Circuit Breakers

Product Selection

Motor Protection Circuit Breakers

- Short Circuit Protection — Standard Magnetic Trip (13...14 x I_e)
- Motor Overload Protection — Trip Class 10

2



Cat. No. 140M-C



Cat. No. 140M-D



Cat. No. 140M-F



Cat. No. 140-CMN

Rated Operational Current (I_e) [A]	Motor Current Adjustment Range [A]	Magnetic Trip Current [A]	Max. Short Circuit Current [kA]		Max. 3-phase Hp Ratings*				Max. kW, 3-Phase — AC-3*				Cat. No.
			400V (I_{cu})	480V (group motor)	200V	230V	460V	575V	230V	400/415V	500V	690V	
C-Frame													
0.16	0.10...0.16	2.1	100	65	—	—	—	—	—	0.02	0.06	0.06	140M-C2E-A16
0.25	0.16...0.25	3.3	100	65	—	—	—	—	—	0.04	0.09	0.09	140M-C2E-A25
0.4	0.25...0.40	5.2	100	65	—	—	—	0.25	0.06	0.09	0.12	0.18	140M-C2E-A40
0.63	0.40...0.63	8.2	100	65	—	—	0.25	0.33	0.09	0.18	0.18	0.25	140M-C2E-A63
1	0.63...1.0	13	100	65	—	—	0.5	0.75	0.18	0.25	0.37	0.55	140M-C2E-B10
1.6	1.0...1.6	21	100	65	0.25	0.33	1	1	0.25	0.55	0.75	1.1	140M-C2E-B16
2.5	1.6...2.5	33	100	65	0.5	0.75	1.5	2	0.37	0.75	1.1	1.8	140M-C2E-B25
4	2.5...4.0	52	100	65	1	1	3	3	0.75	1.5	2.2	3	140M-C2E-B40
6.3	4.0...6.3	82	100	65	1.5	2	5	5	1.5	2.2	3	4	140M-C2E-B63
10	6.3...10	130	100	65	3	3	7.5	10	2.2	4	6.3	7.5	140M-C2E-C10
16	10...16	208	65	30	5	5	10	15	4	7.5	10	13	140M-C2E-C16
20	14.5...20	260	50	30	5	7.5	15	20	5.5	10	11	17	140M-C2E-C20
25	18...25	325	15	25	7.5	7.5	20	20	5.5	11	15	22	140M-C2E-C25
29	24...29	406	15	25	7.5	10	20	25	7.5	13	18.5	25	140M-C2E-C29
32	27...32	448	15	25	7.5	10	25	30	7.5	15	20	25	140M-C2E-C32
D-Frame													
2.5	1.6...2.5	33	100	65	0.5	0.75	1.5	2	0.37	0.75	1.1	1.8	140M-D8E-B25
4	2.5...4.0	52	100	65	1	1	3	3	0.75	1.5	2.2	3	140M-D8E-B40
6.3	4.0...6.3	82	100	65	1.5	2	5	5	1.5	2.2	3	4	140M-D8E-B63
10	6.3...10	130	100	65	3	3	7.5	10	2.2	4	6.3	7.5	140M-D8E-C10
16	10...16	208	100	65	5	5	10	15	4	7.5	10	13	140M-D8E-C16
20	14.5...20	260	100	65	5	7.5	15	20	5.5	10	11	17	140M-D8E-C20
25	18...25	325	65	30	7.5	7.5	20	20	5.5	11	15	22	140M-D8E-C25
29	24...29	406	50	30	7.5	10	20	25	7.5	13	18.5	25	140M-D8E-C29
32	27...32	448	50	30	7.5	10	25	30	7.5	15	20	25	140M-D8E-C32
F-Frame													
10	6.3...10	130	100	65	3	3	7.5	10	2.2	4	6.3	7.5	140M-F8E-C10
16	10...16	208	100	65	5	5	10	15	4	7.5	10	13	140M-F8E-C16
20	14.5...20	260	100	65	5	7.5	15	20	5.5	10	11	17	140M-F8E-C20
25	18...25	325	100	65	7.5	10	20	25	6.3	11	15	22	140M-F8E-C25
32	23...32	416	65	65	7.5	10	25	30	7.5	15	20	30	140M-F8E-C32
45	32...45	585	65	65	10	15	30	40	13	22	30	40	140M-F8E-C45
CMN-Frame													
25	16...25	350	65	65	5	7.5	15	20	7.5	13	15	22	140-CMN-2500
40	25...40	560	65	65	10	10	30	30	11	22	25	30	140-CMN-4000
63	40...63	882	65	42	20	20	40	60	20	32	40	55	140-CMN-6300
90	63...90	1260	50	35	25	30	60	75	25	45	55	75	140-CMN-9000

* Horsepower/kW ratings shown in the table above are for reference. The final selection of the MPCB depends on the actual motor full load current.



Motor Protection Circuit Breakers

- Short Circuit Protection — Standard Magnetic Trip (Fixed at 12...15 x I_e)
- Overload Protection — Trip Class 10...30 (Adjustable)



Cat. No. 140M-I



Cat. No. 140M-J



Cat. No. 140M-L

Rated Operational Current (I_e) [A]	Motor Current Adjustment Range [A]	Magnetic Trip Current [A]	Ultimate Interrupting Current [kA] (I_{cm})		3-phase Hp Ratings*				Max. kW, 3-Phase — AC-3*				Cat. No.
			400V	480V	200V	230V	460V	575V	230V	400/415V	500V	690V	
I-Frame													
80	40...80	1200	70*	65	25	30	60	75	22	37	55	75	140M-I8E-C80*‡
100	80...100	1500	70*	65	30	40	75	100	30	55	55	90	140M-I8E-D10*‡
160	100...160	2400	70*	65	50	60	125	150	45	75	110	132	140M-I8E-D16*‡
205	160...205	2665	70*	65	60	75	150	200	55	110	132	200	140M-I8E-D20*§
J-Frame													
50	20...50	700	25	25	25	30	60	75	15	22	30	45	140M-J2E-C50
100	40...100	1400	25	25	30	40	75	100	30	55	55	90	140M-J2E-D10
160	64...160	2240	25	25	50	60	125	150	45	90	110	160	140M-J2E-D16
250	100...250	3500	25	25	75	100	200	250	55	132	160	250	140M-J2E-D25
L-Frame													
250	100...250	3000	40	35	75	100	200	250	55	132	160	250	140M-L2E-D25
400	160...400	4800	40	35	125	150	300	400	132	200	250	400	140M-L2E-D40
630	250...630	7580	40	35	200	250	500	600	200	355	450	630	140M-L2E-D63
250	100...250	3000	70	65	75	100	200	250	55	132	160	250	140M-L8E-D25
400	160...400	4800	70	65	150	150	350	450	132	200	250	400	140M-L8E-D40
630	250...630	7560	70	65	200	250	500	600	200	355	450	630	140M-L8E-D63

* Horsepower/kW ratings shown in the table above are for reference. **The final selection of the MPCB depends on the actual motor full load current.**

* For IEC approvals and CE marking, add an "E" to the end of the Cat. No. Example: 140M-18E-C80E.

‡ Overload Protection — adjustable Trip Class 5, 10, 15, or 20.

§ Overload Protection — fixed Trip Class 10.

Motor Protection Circuit Breakers

Product Selection

High Inrush Motor Protection Circuit Breakers

- Short Circuit Protection — High Magnetic Trip (Fixed at $16...21 \times I_e$)
- Motor Overload Protection — Trip Class 10

2



Cat. No. 140M-C



Cat. No. 140M-D



Cat. No. 140M-F

Rated Operational Current (I_e) [A]	Motor Current Adjustment Range [A]	Magnetic Trip Current [A]	Max. Short Circuit Current [kA]		Max. 3-phase Hp Ratings*				Max kW, 3-Phase — AC-3*				Cat. No.	
			400V (I_{cu})	480V (group motor)	200V	230V	460V	575V	230V	400/415V	500V	690V		
C-Frame														
0.16	0.10...0.16	3.3	100	65	—	—	—	—	—	0.02	0.06	0.06	140M-C2T-A16	
0.25	0.16...0.25	5.2	100	65	—	—	—	—	—	0.04	0.09	0.09	140M-C2T-A25	
0.4	0.25...0.40	8.2	100	65	—	—	—	0.25	0.33	0.09	0.18	0.18	0.25	140M-C2T-A40
0.63	0.40...0.63	13	100	65	—	—	0.25	0.33	0.09	0.18	0.18	0.25	140M-C2T-A63	
1	0.63...1.0	21	100	65	—	—	0.5	0.75	0.18	0.25	0.37	0.55	140M-C2T-B10	
1.6	1.0...1.6	33	100	65	0.25	0.33	1	1	0.25	0.55	0.75	1.1	140M-C2T-B16	
2.5	1.6...2.5	52	100	65	0.5	0.75	1.5	2	0.37	0.75	1.1	1.8	140M-C2T-B25	
4	2.5...4	82	100	65	1	1	3	3	0.75	1.5	2.2	3	140M-C2T-B40	
6.3	4...6.3	130	100	65	1.5	2	5	5	1.5	2.2	3	4	140M-C2T-B63	
10	6.3...10	208	100	30	3	3	7.5	10	2.2	4	6.3	7.5	140M-C2T-C10	
16	10...16	260	50	30	5	5	10	15	4	7.5	10	13	140M-C2T-C16	
D-Frame														
16	10...16	260	100	65	5	5	10	15	4	7.5	10	13	140M-D8T-C16	
20	14.5...20	325	65	30	5	7.5	15	20	5.5	10	11	17	140M-D8T-C20	
F-Frame														
25	18...25	416	65	65	7.5	10	20	25	6.3	11	15	22	140M-F8T-C25	
32	23...32	585	65	65	7.5	10	25	30	7.5	15	20	30	140M-F8T-C32	

* Horsepower/kW ratings shown in the table above are for reference. **The final selection of the MPCB depends on the actual motor full load current.**

Motor Protection Circuit Breakers — Screwless

- Short Circuit Protection — Standard Magnetic Trip ($13...14 \times I_e$)
- Motor Overload Protection — Trip Class 10



Rated Operational Current (I_e) [A]	Motor Current Adjustment Range [A]	Magnetic Trip Current [A]	Max. Short Circuit Current [kA]		Max. 3-phase Hp Ratings*				Max. kW, 3-Phase — AC-3*				Cat. No.
			400V (I_{cu})	480V (group motor)	200V	230V	460V	575V	230V	400/415V	500V	690V	
C-Frame													
0.16	0.10...0.16	2.1	100	65	—	—	—	—	—	0.02	0.06	0.06	140M-RC2E-A16
0.25	0.16...0.25	3.3	100	65	—	—	—	—	—	0.04	0.09	0.09	140M-RC2E-A25
0.4	0.25...0.40	5.2	100	65	—	—	—	0.25	0.06	0.09	0.12	0.18	140M-RC2E-A40
0.63	0.40...0.63	8.2	100	65	—	—	0.25	0.33	0.09	0.18	0.18	0.25	140M-RC2E-A63
1	0.63...1.0	13	100	65	—	—	0.5	0.75	0.18	0.25	0.37	0.55	140M-RC2E-B10
1.6	1.0...1.6	21	100	65	0.25	0.33	1	1	0.25	0.55	0.75	1.1	140M-RC2E-B16
2.5	1.6...2.5	33	100	65	0.5	0.75	1.5	2	0.37	0.75	1.1	1.8	140M-RC2E-B25
4	2.5...4.0	52	100	65	1	1	3	3	0.75	1.5	2.2	3.0	140M-RC2E-B40
6.3	4.0...6.3	82	100	65	1.5	2	5	5	1.5	2.2	3.0	4.0	140M-RC2E-B63
10	6.3...10	130	100	65	3	3	7.5	10	2.2	4.0	6.3	7.5	140M-RC2E-C10
16	10...16	208	65	30	5	5	10	15	4.0	7.5	10	13	140M-RC2E-C16

* Horsepower/kW ratings shown in the table above are for reference. **The final selection of the MPCB depends on the actual motor full load current.**

Motor Circuit Protectors

Product Overview

2



Bulletin 140M Motor Circuit Protectors

- Current range 0.16...1200 A
- UL Listed/Recognized for motor loads
 - Short-circuit protection
 - Overload protection must be provided separately
- Visible trip indication
- High current limiting
- High switching capacity

The Bulletin 140M Motor Circuit Protectors provide short circuit protection for individual motor loads. Factory-installed internal accessories make installation and wiring easy.

Certifications (0.16...45 A)

CE Marked
 cULus Listed (File No. E54612,
 Guide No. NLRV, NLRV7)
 CCC

Certifications (3...1200 A)

UR Recognized component
 (File No. E224135, Guide
 DKPU2)
 CSA Certified (Class No.
 3211-07)

Table of Contents

Product Selection —
 Motor Circuit
 Protectors 2-16
 Approximate
 Dimensions..... 2-51

Standards Compliance

IEC/EN 60947-1, 2, -4-1, -5-1
 IEC/EN 60204-1
 CSA, C22.2 No.14
 UL 508
 UL 489 (H-, J-, L-, N-Frame)

General Information

Motor Circuit Protectors may provide the following protective and control functions.

- Disconnect for Motor Branch Circuit
- Branch-Circuit, Short-Circuit Protection (Magnetic Protection)
- Switching (Manual)

In North America, electrical codes require that an individual Motor Branch Circuit be protected by a UL/CSA Listed Fuse, Circuit Breaker or Self-Protected Combination Motor Controller.

140M-C, D and F Frames:

The 140M-C, D and F frame Motor Circuit Protectors have one UL/CSA Listing – as Manual Motor Controllers (with optional approvals for Motor Disconnect and Group Installation). In NEC/CEC Group Installations, these devices must be applied per the appropriate rules which require the use of an upstream Branch-Circuit, Short-Circuit Protective Device (BCPD). See the table on page 2-20 for the specific ratings of each Motor Circuit Protector.

The 140M-C, D and F Frame Motor Circuit Protectors are also UL/CSA Listed, together with a Bulletin 100C contactor and Bulletin 193 overload relay, as part of our Bulletin 103T and 107T Self-Protected IEC Combination Starters. These starters are then able to provide all of the necessary NEC/CEC requirements for the protection and control of individual Motor Branch Circuits without additional protective devices.

140M-H, J and L Frames:







The 140M-H, J and L frame Motor Circuit Protectors are UL/CSA Recognized as Circuit Breakers as shown in the table on page 2-20. They are UL/CSA Recognized, rather than UL/CSA Listed, since they only provide short circuit protection and not thermal overload protection for the motor.

140M-H, J and L frame Motor Circuit Protectors (MCPs) are also UL/CSA Listed, together with a Bulletin 100C contactor and Bulletin 193 overload relay, as part of our Bulletin 113 IEC Combination Starters. These starters are then able to provide all of the necessary NEC/CEC requirements for the protection and control of individual Motor Branch Circuits without additional protective devices.

Motor Circuit Protectors

Product Overview/Catalog Number Explanation

Product Line Overview

							
	C-Frame	D-Frame	F-Frame	H-Frame	J-Frame	L-Frame	N-Frame
Max. Current I_e	25 A	32 A	45 A	100 A	250 A	600 A	1200 A
Current Rating	0.16...2.5 A	2.5...32 A	25...45 A	3...100	70...250	125...600	640...1200
Short Circuit Protection	✓	✓	✓	✓	✓	✓	✓
Standards Compliance:							
CSA 22.2, No. 14	✓	✓	✓				
CSA 22.2, No. 5	—	—	—	✓	✓	✓	✓
UL 508 (Group Install.)	✓	✓	✓				
UL489 (Recognized)	—	—	—	✓	✓	✓	✓
IEC 60947-2	✓	✓	✓	✓	✓	✓	✓
CE	✓	✓	✓	✓	✓	✓	✓
CCC	✓	✓ (up to 25 A)	✓	—	—	—	—
Accessories							
Ext. Rotary Operator	✓	✓	✓	✓	✓	✓	✓
Flex Cable Operator	—	—	—	✓	✓	✓	✓
Auxiliary Contacts	✓	✓	✓	✓	✓	✓	✓
Trip Indication Contacts	✓	✓	✓	✓	✓	✓	✓



Cat. No. Explanation

Examples given in this section are for reference purposes. This basic explanation should not be used for product selection; not all combinations will produce a valid catalog number.

140M - **C** - **2** - **N** - **A63** - **KN** - **CC** - **GJ**
a *b* *c* *d* *e* *f* *g* *h*

<p style="text-align: center;">a</p> <table border="1" style="width: 100%;"> <tr><th colspan="2">Bulletin Number</th></tr> <tr><th>Code</th><th>Description</th></tr> <tr><td>140M</td><td>Motor Circuit Protectors (MCPs)</td></tr> </table> <p style="text-align: center;">b</p> <table border="1" style="width: 100%;"> <tr><th colspan="2">Frame Size and Rating</th></tr> <tr><th>Code</th><th>Description</th></tr> <tr><td>C</td><td>25 A</td></tr> <tr><td>D</td><td>32 A</td></tr> <tr><td>F</td><td>45 A</td></tr> <tr><td>H</td><td>125 A</td></tr> <tr><td>J</td><td>250 A</td></tr> <tr><td>L</td><td>400 A and 600 A</td></tr> <tr><td>N</td><td>800 A and 1200 A</td></tr> </table> <p style="text-align: center;">c</p> <table border="1" style="width: 100%;"> <tr><th colspan="2">Interrupting Rating / Breaking Capacity (I_c at 480V)</th></tr> <tr><th>Code</th><th>Description</th></tr> <tr><td>2</td><td>Normal Break</td></tr> <tr><td>8</td><td>High Break</td></tr> </table>	Bulletin Number		Code	Description	140M	Motor Circuit Protectors (MCPs)	Frame Size and Rating		Code	Description	C	25 A	D	32 A	F	45 A	H	125 A	J	250 A	L	400 A and 600 A	N	800 A and 1200 A	Interrupting Rating / Breaking Capacity (I_c at 480V)		Code	Description	2	Normal Break	8	High Break	<p style="text-align: center;">d</p> <table border="1" style="width: 100%;"> <tr><th colspan="2">Protection Type</th></tr> <tr><th>Code</th><th>Description</th></tr> <tr><td>N</td><td>Fixed Mag Only (13...14 x I_n)</td></tr> <tr><td>P</td><td>Adj Mag Only (less than 13 x I_n) - MCPs</td></tr> <tr><td>R</td><td>Adj Mag Only (greater than 13 x I_n) - MCP's</td></tr> </table> <p style="text-align: center;">e</p> <table border="1" style="width: 100%;"> <tr><th colspan="3">Current Range</th></tr> <tr><th>Code</th><th>Description</th><th>Example</th></tr> <tr><td>A</td><td>A = .10</td><td>A16 = 0.16</td></tr> <tr><td>B</td><td>B = 1.0</td><td>B16 = 1.6</td></tr> <tr><td>C</td><td>C = 10</td><td>C16 = 16</td></tr> <tr><td>D</td><td>D = 100</td><td>D16 = 160</td></tr> <tr><td>E</td><td>E = 1000</td><td>E16 = 1600</td></tr> </table>	Protection Type		Code	Description	N	Fixed Mag Only (13...14 x I_n)	P	Adj Mag Only (less than 13 x I_n) - MCPs	R	Adj Mag Only (greater than 13 x I_n) - MCP's	Current Range			Code	Description	Example	A	A = .10	A16 = 0.16	B	B = 1.0	B16 = 1.6	C	C = 10	C16 = 16	D	D = 100	D16 = 160	E	E = 1000	E16 = 1600	<p style="text-align: center;">f, g, h</p> <table border="1" style="width: 100%;"> <tr><td>Factory-Installed Options</td></tr> </table> <p style="text-align: center;">f</p> <table border="1" style="width: 100%;"> <tr><td>Miscellaneous See page 2-36</td></tr> </table> <p style="text-align: center;">g</p> <table border="1" style="width: 100%;"> <tr><td>Aux/Trip Contacts See page 2-36</td></tr> </table> <p style="text-align: center;">h</p> <table border="1" style="width: 100%;"> <tr><td>UV and Shunt Trips See page 2-36</td></tr> </table>	Factory-Installed Options	Miscellaneous See page 2-36	Aux/Trip Contacts See page 2-36	UV and Shunt Trips See page 2-36
Bulletin Number																																																																					
Code	Description																																																																				
140M	Motor Circuit Protectors (MCPs)																																																																				
Frame Size and Rating																																																																					
Code	Description																																																																				
C	25 A																																																																				
D	32 A																																																																				
F	45 A																																																																				
H	125 A																																																																				
J	250 A																																																																				
L	400 A and 600 A																																																																				
N	800 A and 1200 A																																																																				
Interrupting Rating / Breaking Capacity (I_c at 480V)																																																																					
Code	Description																																																																				
2	Normal Break																																																																				
8	High Break																																																																				
Protection Type																																																																					
Code	Description																																																																				
N	Fixed Mag Only (13...14 x I_n)																																																																				
P	Adj Mag Only (less than 13 x I_n) - MCPs																																																																				
R	Adj Mag Only (greater than 13 x I_n) - MCP's																																																																				
Current Range																																																																					
Code	Description	Example																																																																			
A	A = .10	A16 = 0.16																																																																			
B	B = 1.0	B16 = 1.6																																																																			
C	C = 10	C16 = 16																																																																			
D	D = 100	D16 = 160																																																																			
E	E = 1000	E16 = 1600																																																																			
Factory-Installed Options																																																																					
Miscellaneous See page 2-36																																																																					
Aux/Trip Contacts See page 2-36																																																																					
UV and Shunt Trips See page 2-36																																																																					

Group Installation with MCPs

There is only one Branch Circuit Protective Device (BCPD) for the “Group”

Group installation has been successfully used for many years in the U.S. and Canada. It allows “two or motors or one or more motors and other loads to be connected to the same branch-circuit...”. The most restrictive part of the conditions specified for Group Installation is the requirement for the protection of the conductors for each motor circuit. Below is an example that illustrates installations involving multiple motors with a single BCPD protecting the entire “Group”.

Bulletin 140M Motor Circuit Protectors UL/CSA Listed for Group Installation

Conductors from the BCPD to each motor must be a minimum of 1/3 the ampacity of the Branch Circuit conductors. Motor Circuit Protectors do not provide thermal protection, so a separate overload relay must be used. Therefore, MCPs cannot be UL/CSA Listed for Tap Conductor Protection in Group Installations.

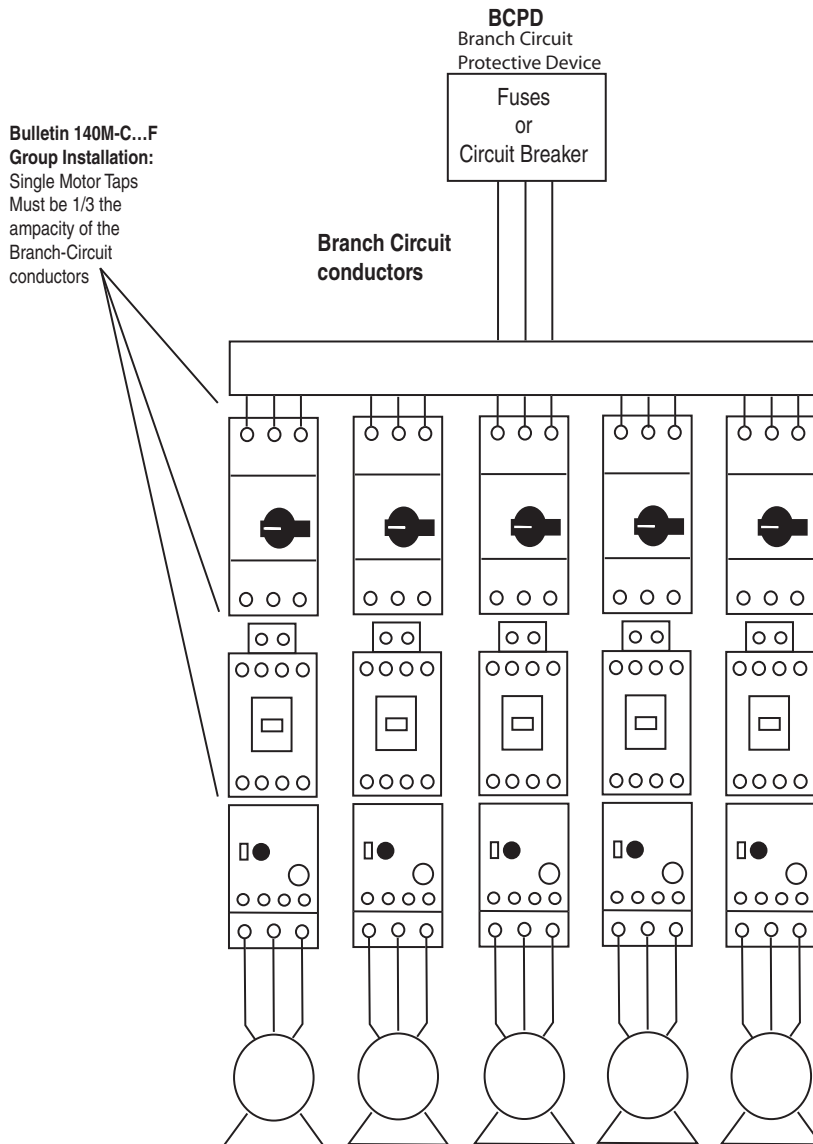

Group Motor Installation

3-Phase Power Supply

Multiple Motor Installation with MCPs
 Each Motor has an Individual Branch Circuit Protective Device (BCPD)

Bulletin140M Motor Circuit Protectors are UL/CSA listed as part of a Combination Motor Controller or a Self-Protected Combination Motor Controller consisting of a 140M Motor Circuit Protector, a 100C Contactor and a 193 Overload Relay. These UL/CSA listings allow the Bulletin 140M MCP's to provide the branch-circuit, short-circuit protection for each individual motor circuit. Additional short-circuit protection is not required for the protection of the individual motor circuits, leaving only the requirement for protection of the Feeder-Circuit conductors by an upstream protective device. Below is an example that illustrates installations involving multiple motors, each with their own branch-circuit protection (BCPD).

Bulletin 140M-H..N
 (UL/CSA recognized Instantaneous Trip Circuit Breakers)
 As part of a listed Combination Motor Controller
 these devices may provide the branch-circuit
 protection for each Individual Motor Circuit.

Bulletin 140M-C..F
 (UL/CSA listed Manual Motor Controllers)
 As part of a listed Self-Protected Combination Motor Controller
 these devices may provide the branch-circuit
 protection for each Individual Motor Circuit

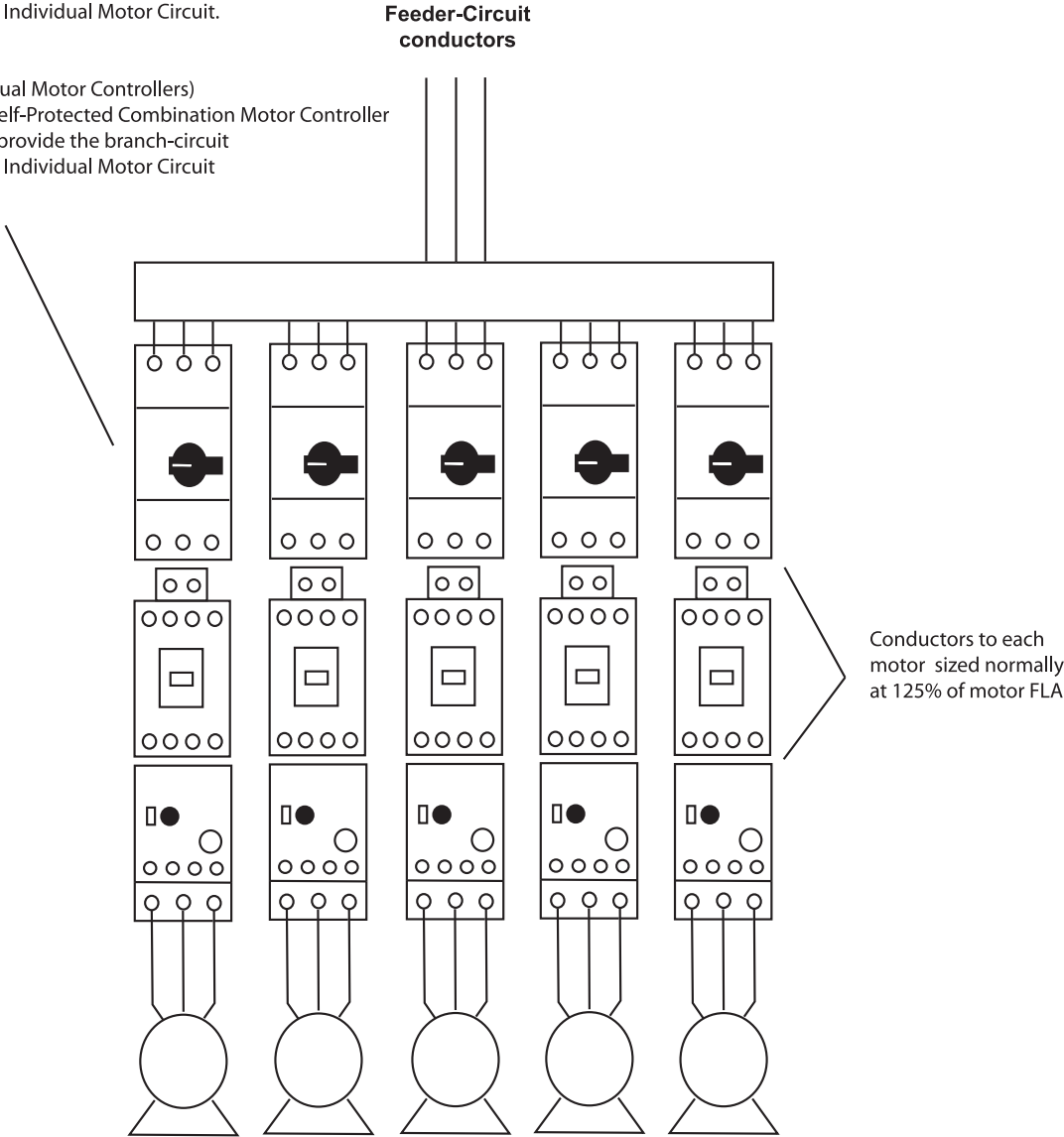

Motor Circuit Protectors

- Short circuit protection — standard magnetic trip (13...14 x I_e)
- Short circuit protection for 3 component starters — No motor overload protection
– separate Bulletin 193-E or 193-T product required for overload and installation protection
- For Trip Class 10 motor applications



Cat. No. 140M-C



Cat. No. 140M-D



Cat. No. 140M-F

Rated Operational Current (I _e) [A]	Magnetic Trip Current [A]	Ultimate Interrupting Current [kA]		Max. 3-phase Hp Ratings*				Max. kW, 3-Phase — AC-3*				Cat. No.
		400V (I _{cu})	480V (group motor)	200V	230V	460V	575V	230V	400/415V	500V	690V	
C-Frame												
0.16	2.1	100	65	—	—	—	—	—	0.02	0.06	0.06	140M-C2N-A16
0.25	3.3	100	65	—	—	—	—	—	0.04	0.09	0.09	140M-C2N-A25
0.4	5.2	100	65	—	—	—	0.25	0.06	0.09	0.12	0.18	140M-C2N-A40
0.63	8.2	100	65	—	—	0.25	0.33	0.09	0.18	0.18	0.25	140M-C2N-A63
1	13	100	65	—	—	0.5	0.75	0.18	0.25	0.37	0.55	140M-C2N-B10
1.6	21	100	65	0.25	0.33	1	1	0.25	0.55	0.75	1.1	140M-C2N-B16
2.5	33	100	65	0.5	0.75	1.5	2	0.37	0.75	1.1	1.8	140M-C2N-B25
D-Frame												
2.5	33	100	65	0.5	0.75	1.5	2	0.37	0.75	1.1	1.8	140M-D8N-B25
4	52	100	65	1	1	3	3	0.75	1.5	2.2	3	140M-D8N-B40
6.3	82	100	65	1.5	2	5	5	1.5	2.2	3	4	140M-D8N-B63
10	130	100	65	3	3	7.5	10	2.2	4	6.3	7.5	140M-D8N-C10
16	208	100	65	5	5	10	15	4	7.5	10	13	140M-D8N-C16
25	325	65	30	7.5	7.5	20	20	5.5	11	15	22	140M-D8N-C25
32	448	50	30	7.5	10	25	30	7.5	15	20	25	140M-D8N-C32
F-Frame												
25	325	100	65	7.5	10	20	25	6.3	11	15	22	140M-F8N-C25
32	416	65	65	7.5	10	25	30	7.5	15	20	30	140M-F8N-C32
45	585	65	65	10	15	30	40	13	22	30	40	140M-F8N-C45

* Horsepower/kW ratings shown in the table above are for reference. **The final selection of the manual starter depends on the actual motor full load current.**

Note: In applications with 140M-C_N, 140M-D_N and 140M-F_N as the short circuit protection device of heavy duty starting motors, the rated operational current I_e of the above devices must be over-dimensioned with following factors:

- CLASS 10 = 1.00
- CLASS 15 = 1.22
- CLASS 20 = 1.42
- CLASS 25 = 1.58
- CLASS 30 = 1.73

Motor Circuit Protectors

- Short-Circuit Protection — Magnetic Trip (Adjustable at 3...10 x I_a)
- Overload Protection — None (Magnetic Trip Only)



Cat. No. 140M-H



Cat. No. 140M-J



Cat. No. 140M-L

Rated Operational Current (I _a) [A]	Magnetic Trip Current [A]									3-phase Hp Ratings*				Max. kW, 3-Phase — AC-3*				Cat. No.*
	Cam Setting																	
	A	B	C	D	E	F	G	H	I	200V	230V	460V	575V	230V	400/415V	500V	690V	
H-Frame																		
3	9	15	21	27	30	33	—	—	—	0.5	0.5	1.5	2	0.6	0.75	1.1	1.5	140M-H8P-B30
7	21	35	49	63	70	77	—	—	—	1.5	2	3	5	1.1	2.2	3	4	140M-H8P-B70
15	45	75	100	135	150	165	—	—	—	3	3	10	10	3	5.5	7.5	11	140M-H8P-C15
30	90	150	210	270	300	330	—	—	—	7.5	10	20	25	5.5	11	15	22	140M-H8P-C30
50	150	250	350	450	500	550	—	—	—	15	15	30	40	11	22	22	37	140M-H8P-C50
70	210	350	490	630	700	770	—	—	—	20	25	50	60	15	30	37	55	140M-H8P-C70
100	300	500	700	900	1000	1100	—	—	—	25	30	60	75	22	45	55	75	140M-H8P-D10
100	500	700	900	1100	1300	1500	—	—	—	30	30	75	100	30	55	75	110	140M-H8R-D10
J-Frame																		
100	500	600	700	800	900	1000	—	—	—	30	30	75	100	22	37	45	55	140M-J8P-D10
125	625	750	875	1000	1125	1250	—	—	—	40	40	100	125	22	45	55	90	140M-J8P-D12
150	750	900	1050	1200	1350	1500	—	—	—	50	50	100	150	30	55	75	110	140M-J8P-D15
175	875	1050	1225	1400	1575	1750	—	—	—	50	60	125	150	37	55	90	132	140M-J8P-D17
200	1000	1200	1400	1600	1800	2000	—	—	—	60	75	150	200	45	75	90	132	140M-J8P-D20
225	1125	1350	1575	1800	2025	2250	—	—	—	75	75	150	200	55	90	110	160	140M-J8P-D22
250	1250	1500	1750	2000	2250	2500	—	—	—	75	100	200	250	55	90	132	160	140M-J8P-D25
L-Frame																		
225	1125	1265	1410	1545	1690	1830	1970	2110	2250	50	60	125	150	55	90	110	160	140M-L8P-D22
250	1250	1405	1560	1720	1875	2030	2185	2340	2500	60	75	150	200	55	90	132	160	140M-L8P-D25
300	1500	1690	1875	2060	2250	2440	2625	2810	3000	75	75	150	200	55	110	160	200	140M-L8P-D30
350	1750	1970	2190	2410	2625	2840	3065	3285	3500	75	100	200	250	75	132	160	250	140M-L8P-D35
400	2000	2250	2500	2750	3000	3250	3500	3750	4000	100	100	250	300	90	160	200	250	140M-L8P-D40
450	2250	2530	2810	3098	3375	3660	3940	4220	4500	100	125	250	350	110	160	200	315	140M-L8P-D45
500	2500	2810	3125	3440	3750	4060	4375	4690	5000	125	150	300	400	110	200	250	355	140M-L8P-D50
600	3000	3375	3760	4110	4500	4880	5250	5630	6000	150	150	350	450	132	250	315	450	140M-L8P-D60
N-Frame																		
800	1600	2400	3200	4000	4800	5600	6400	—	—	150	200	400	500	160	250	355	500	140M-N8P-D80
1200	2400	3600	4800	6000	7200	8400	9600	—	—	250	300	600	700	200	250	500	710	140M-N8P-E12

* The Hp and kW ratings shown are for reference only. They allow for a magnetic trip setting of at least up to 13X the motor FLA. However, the final selection of the MCP should be made based on motor full load current and the requirements of local electrical codes.
 * The interrupting rating for MCPs is dependent upon the controller used. Please contact your local Rockwell Automation sales office or Allen-Bradley distributor for further information.

Motor Protection Circuit Breakers and Motor Circuit Protectors

Application Ratings

UL/CSA Listed Application Ratings — Motor Protection Circuit Breaker (MPCB) Only

Cat. No.	Max. Fuse or C.B. per NEC	UL 508 — Manual Motor Controller						UL 508 Self-Protected (Type E) Combination Motor Controller		UL 489 Inverse Time C.B. w/UL 508 Motor Overload Protection	
		Group Motor Installation		Motor Disconnect		Tap Conductor Protection		Max. Short Circuit Current [kA]		Max. Short Circuit Current [kA]	
		480V	600V	480V	600V	480V	600V	480Y/277V‡	600Y/347V‡	480V	600V
C-Frame											
140M-C2E-A16	450	65	47	65	47	65	47	65	47	—	—
140M-C2E-A25	450	65	47	65	47	65	47	65	47	—	—
140M-C2E-A40	450	65	47	65	47	65	47	65	47	—	—
140M-C2E-A63	450	65	47	65	47	65	47	65	47	—	—
140M-C2E-B10	450	65	47	65	47	65	47	65	47	—	—
140M-C2E-B16	450	65	47	65	47	65	47	65	47	—	—
140M-C2E-B25	450	65	30	65	30	65	30	65	30	—	—
140M-C2E-B40	450	65	25	65	25	65	25	65	25	—	—
140M-C2E-B63	450	65	30	65	30	65	—	65	—	—	—
140M-C2E-C10	450	65	30	65	30	65	—	65	—	—	—
140M-C2E-C16	450	30	30	30	30	30	—	30	—	—	—
140M-C2E-C20	450	30	30	10	10	10	—	10	—	—	—
140M-C2E-C25	450	25	10	10	5	—	—	—	—	—	—
140M-C2E-C29	450	25	5	10	—	—	—	—	—	—	—
140M-C2E-C32	450	25	5	10	—	—	—	—	—	—	—
D-Frame											
140M-D8E-B25	450	65	30	65	30	65	30	65	30	—	—
140M-D8E-B40	450	65	30	65	30	65	30	65	30	—	—
140M-D8E-B63	450	65	30	65	30	65	30	65	30	—	—
140M-D8E-C10	450	65	30	65	30	65	30	65	30	—	—
140M-D8E-C16	450	65	30	65	30	65	30	65	30	—	—
140M-D8E-C20	450	65	30	65	30	65	—	65	—	—	—
140M-D8E-C25	450	30	30	30	30	30	—	30	—	—	—
140M-D8E-C29	450	30	30	30	18	—	—	—	—	—	—
140M-D8E-C32	450	30	30	30	18	—	—	—	—	—	—
F-Frame											
140M-F8E-C10	600	65	30	65	30	65	30	65	30	—	—
140M-F8E-C16	600	65	30	65	30	65	30	65	30	—	—
140M-F8E-C20	600	65	30	65	30	65	30	65	30	—	—
140M-F8E-C25	600	65	30	65	30	65	30	65	30	—	—
140M-F8E-C32	600	65	30	65	30	65	30	65	30	—	—
140M-F8E-C45	600	65	18	65	18	65	—	65	—	—	—
CMN-Frame											
140-CMN-2500	1000	65	42	—	—	—	—	—	—	—	—
140-CMN-4000	1000	65	42	—	—	—	—	—	—	—	—
140-CMN-6300	1000	42	18	—	—	—	—	—	—	—	—
140-CMN-9000	1000	35	10	—	—	—	—	—	—	—	—
I-Frame											
140M-I8E-C80	—	—	—	—	—	—	—	—	—	65	30
140M-I8E-D10	—	—	—	—	—	—	—	—	—	65	30
140M-I8E-D16	—	—	—	—	—	—	—	—	—	65	30
140M-I8E-D20	—	—	—	—	—	—	—	—	—	65	30
J-Frame											
140M-J2E-C50	—	—	—	—	—	—	—	—	—	25	18
140M-J2E-D10	—	—	—	—	—	—	—	—	—	25	18
140M-J2E-D16	—	—	—	—	—	—	—	—	—	25	18
140M-J2E-D25	—	—	—	—	—	—	—	—	—	25	18
140M-J8E-C50	—	—	—	—	—	—	—	—	—	65	25
140M-J8E-D10	—	—	—	—	—	—	—	—	—	65	25
140M-J8E-D16	—	—	—	—	—	—	—	—	—	65	25
140M-J8E-D25	—	—	—	—	—	—	—	—	—	65	25
L-Frame											
140M-L2E-D25	—	—	—	—	—	—	—	—	—	25	18
140M-L2E-D40	—	—	—	—	—	—	—	—	—	25	18
140M-L2E-D63	—	—	—	—	—	—	—	—	—	25	18
140M-L8E-D25	—	—	—	—	—	—	—	—	—	65	35
140M-L8E-D40	—	—	—	—	—	—	—	—	—	65	35
140M-L8E-D63	—	—	—	—	—	—	—	—	—	65	35

‡ For full voltage (delta) ratings above 277V or 347V, follow the NEC or CEC rules for group motor applications.

Motor Protection Circuit Breakers and Motor Circuit Protectors

Application Ratings

UL/CSA Listed Application Ratings — Motor Protection Circuit Breaker (MPCB) Only, Continued

Cat. No.	Max. Fuse or C.B. per NEC	UL 508 Manual Motor Controller						UL 508 Self-Protected (Type E) Combination Motor Controller	
		Group Motor Installation		Motor Disconnect		Tap Conductor Protection		Max. Short Circuit Current [kA]	
		Max. Short Circuit Current [kA]		Max. Short Circuit Current [kA]		Max. Short Circuit Current [kA]		Max. Short Circuit Current [kA]	
		480V	600V	480V	600V	480V	600V	480Y/277V‡	600Y/347V‡
C-Frame									
140M-C2T-A16	450	65	47	65	47	65	47	65	47
140M-C2T-A25	450	65	47	65	47	65	47	65	47
140M-C2T-A40	450	65	47	65	47	65	47	65	47
140M-C2T-A63	450	65	47	65	47	65	47	65	47
140M-C2T-B10	450	65	47	65	47	65	47	65	47
140M-C2T-B16	450	65	47	65	47	65	30	65	30
140M-C2T-B25	450	65	25	65	25	65	25	65	25
140M-C2T-B40	450	65	30	65	30	65	—	65	—
140M-C2T-B63	450	65	30	65	30	65	—	65	—
140M-C2T-C10	450	30	30	30	30	30	—	30	—
140M-C2T-C16	450	30	30	10	10	10	—	10	—
D-Frame									
140M-D8T-C16	450	65	30	65	30	65	30	65	30
140M-D8T-C20	450	30	30	30	30	30	—	30	—
F-Frame									
140M-F8T-C25	600	65	30	65	30	65	30	65	30
140M-F8T-C32	600	65	18	65	18	65	18	65	18

‡ For full voltage (delta) ratings above 277V or 347V, follow the NEC or CEC rules for group motor applications.

Motor Protection Circuit Breakers and Motor Circuit Protectors

Application Ratings

UL Listed Application Ratings — Motor Circuit Protectors Only§

Cat. No.	UL 508 Manual Motor Controller						UL 489 Instantaneous Trip Circuit Breaker (Magnetic Only)	
	Max. Fuse or C.B. per NEC	Group Motor Installation		Motor Disconnect		Motor Circuit Protector		
		Max. Short Circuit Current [kA]		Max. Short Circuit Current [kA]		Max. Short Circuit Current [kA]‡		
		480V	600V	480V	600V	480V	600V	
C-Frame								
140M-C2N-A16	450	65	47	65	47	—	—	
140M-C2N-A25	450	65	47	65	47	—	—	
140M-C2N-A40	450	65	47	65	47	—	—	
140M-C2N-A63	450	65	47	65	47	—	—	
140M-C2N-B10	450	65	47	65	47	—	—	
140M-C2N-B16	450	65	47	65	47	—	—	
140M-C2N-B25	450	65	30	65	30	—	—	
D-Frame								
140M-D8N-B25	450	65	30	65	30	—	—	
140M-D8N-B40	450	65	30	65	30	—	—	
140M-D8N-B63	450	65	30	65	30	—	—	
140M-D8N-C10	450	65	30	65	30	—	—	
140M-D8N-C16	450	65	30	65	30	—	—	
140M-D8N-C25	450	30	30	30	30	—	—	
140M-D8N-C32	450	30	30	30	18	—	—	
F-Frame								
140M-F8N-C25	600	65	30	65	30	—	—	
140M-F8N-C32	600	65	30	65	30	—	—	
140M-F8N-C45	600	65	18	65	18	—	—	
H-Frame								
140M-H8P-B30	—	—	—	—	—	65	30	
140M-H8P-B70	—	—	—	—	—	65	30	
140M-H8P-C15	—	—	—	—	—	65	30	
140M-H8P-C30	—	—	—	—	—	65	30	
140M-H8P-C50	—	—	—	—	—	65	30	
140M-H8P-C70	—	—	—	—	—	65	30	
140M-H8P-D10	—	—	—	—	—	65	30	
140M-H8P-D10	—	—	—	—	—	65	30	
J-Frame								
140M-J8P-C70	—	—	—	—	—	65	30	
140M-J8P-C90	—	—	—	—	—	65	30	
140M-J8P-D10	—	—	—	—	—	65	30	
140M-J8P-D12	—	—	—	—	—	65	30	
140M-J8P-D15	—	—	—	—	—	65	30	
140M-J8P-D17	—	—	—	—	—	65	30	
140M-J8P-D20	—	—	—	—	—	65	30	
140M-J8P-D22	—	—	—	—	—	65	30	
140M-J8P-D25	—	—	—	—	—	65	30	
L-Frame								
140M-L8P-D22	—	—	—	—	—	65	30	
140M-L8P-D25	—	—	—	—	—	65	30	
140M-L8P-D30	—	—	—	—	—	65	30	
140M-L8P-D35	—	—	—	—	—	65	30	
140M-L8P-D40	—	—	—	—	—	65	30	
140M-L8P-D45	—	—	—	—	—	65	30	
140M-L8P-D50	—	—	—	—	—	65	30	
140M-L8P-D60	—	—	—	—	—	65	30	
N-Frame								
140M-N8P-D80	—	—	—	—	—	65	35	
140M-N8P-E12	—	—	—	—	—	65	35	

§ Separate overload protection is required.

‡ The interrupting rating for MCPs is dependent upon the controller used. Contact your local Rockwell Automation sales office or Allen-Bradley distributor for further information.

Motor Protection Circuit Breakers and Motor Circuit Protectors

Application Ratings

UL Listed Application Ratings - Motor Protection Circuit Breakers with Bulletin 100-K Contactors

Cat. No.	UL 508 Manual Motor Controller						UL 508 Type F Combination Motor Controller			UL 508 Type E Self-Protected Combination Motor Controller		
	Max. Fuse or C.B. per NEC	Minimum Contactor Size	Group Motor Installation		Motor Disconnect		Minimum Contactor Size	Max. Short Circuit Current [kA]		Minimum Contactor Size	Max. Short Circuit Current [kA]	
			480V	600V	480V	600V		480Y/277V§	600Y/347V§		480Y/277V§	600Y/347V§
C-Frame												
140M-C2E-A16	450	100-K05	65	47	65	47	100-K05	65	47	—	—	—
140M-C2E-A25	450	100-K05	65	47	65	47	100-K05	65	47	—	—	—
140M-C2E-A40	450	100-K05	65	47	65	47	100-K05	65	47	—	—	—
140M-C2E-A63	450	100-K05	65	47	65	47	100-K05	65	47	—	—	—
140M-C2E-B10	450	100-K05	65	47	65	47	100-K05	65	47	—	—	—
140M-C2E-B16	450	100-K05	65	47	65	47	100-K05	65	47	—	—	—
140M-C2E-B25	450	100-K05	65	30	65	30	100-K05	65	30	—	—	—
140M-C2E-B40	450	100-K05	65	30	65	30	100-K05	65	30	—	—	—
140M-C2E-B63	450	100-K05	65	30	65	30	100-K05	65	—	—	—	—
140M-C2E-C10	450	100-K09	65	30	65	30	100-K09	65	—	—	—	—
140M-C2E-C16	450	100-K12	30	30	30	30	100-K12	30	—	—	—	—
D-Frame												
140M-D8E-B25	450	100-K05	65	30	65	30	100-K05	65	30	—	—	—
140M-D8E-B40	450	100-K05	65	30	65	30	100-K05	65	30	—	—	—
140M-D8E-B63	450	100-K05	65	30	65	30	100-K05	65	30	—	—	—
140M-D8E-C10	450	100-K09	65	30	65	30	100-K09	65	30	—	—	—
140M-D8E-C16	450	100-K12	65	30	65	30	100-K12	65	30	—	—	—

§ For full voltage (delta) ratings above 277V or 347V, follow the NEC or CEC rules for group motor applications.

Motor Protection Circuit Breakers and Motor Circuit Protectors

Application Ratings

UL Listed Application Ratings - Motor Protection Circuit Breakers with Bulletin 100-C Contactors

Cat. No.	UL 508 Manual Motor Controller						UL 508 Type F Combination Motor Controller			UL 508 Type E Self-Protected Combination Motor Controller		
	Max. Fuse or C.B. per NEC	Minimum Contactor Size	Group Motor Installation		Motor Disconnect		Minimum Contactor Size	Max. Short Circuit Current [kA]		Minimum Contactor Size	Max. Short Circuit Current [kA]	
			480V	600V	480V	600V		480Y/277V§	600Y/347V§		480Y/277V§	600Y/347V§
C-Frame												
140M-C2E-A16	450	100-C09	65	47	65	47	100-C09	65	47	100-C09	65	47
140M-C2E-A25	450	100-C09	65	47	65	47	100-C09	65	47	100-C09	65	47
140M-C2E-A40	450	100-C09	65	47	65	47	100-C09	65	47	100-C09	65	47
140M-C2E-A63	450	100-C09	65	47	65	47	100-C09	65	47	100-C09	65	47
140M-C2E-B10	450	100-C09	65	47	65	47	100-C09	65	47	100-C09	65	47
140M-C2E-B16	450	100-C09	65	47	65	47	100-C09	65	47	100-C09	65	47
140M-C2E-B25	450	100-C09	65	30	65	30	100-C09	65	30	100-C09	65	30
140M-C2E-B40	450	100-C09	65	30	65	30	100-C09	65	30	—	65	25
140M-C2E-B63	450	100-C09	65	30	65	30	100-C09	65	—	—	65	—
140M-C2E-C10	450	100-C09	65	30	65	30	100-C09	65	—	—	65	—
140M-C2E-C16	450	100-C12	30	30	30	25	100-C12	30	—	—	30	—
140M-C2E-C20	450	100-C16	30	30	30	30	100-C23	10	—	—	10	—
140M-C2E-C25	450	100-C23	30	30	10	10	—	—	—	—	—	—
	450	100-C30	30	30	30	30	—	—	—	—	—	—
140M-C2E-C29	450	100-C30	10	5	10	5	—	—	—	—	—	—
140M-C2E-C32	450	100-C37	10	5	10	5	—	—	—	—	—	—
D-Frame												
140M-D8E-B25	450	100-C09	65	30	65	30	100-C09	65	30	100-C09	65	30
	—	—	—	—	—	—	—	—	—	100-C23	65	30
140M-D8E-B40	450	100-C09	65	30	65	30	100-C09	65	30	100-C23	65	30
140M-D8E-B63	450	100-C09	65	30	65	30	100-C09	65	30	100-C30	65	30
140M-D8E-C10	450	100-C09	65	30	65	30	100-C09	65	30	100-C30	65	30
140M-D8E-C16	450	100-C12	65	30	65	30	100-C12	65	30	100-C30	65	30
140M-D8E-C20	450	100-C23	65	30	65	30	100-C23	65	—	100-C30	65	—
140M-D8E-C25	450	100-C23	65	30	65	30	100-C23	30	—	100-C30	30	—
140M-D8E-C29	450	100-C30	65	10	65	10	—	—	—	—	—	—
140M-D8E-C32	450	100-C37	65	10	65	10	—	—	—	—	—	—
F-Frame												
140M-F8E-C10	600	100-C30	65	30	65	30	100-C30	65	30	100-C30	65	30
140M-F8E-C16	600	100-C30	65	30	65	30	100-C30	65	30	100-C30	65	30
140M-F8E-C20	600	100-C30	65	30	65	30	100-C30	65	30	100-C30	65	30
140M-F8E-C25	600	100-C30	65	30	65	30	100-C30	65	30	100-C30	65	30
140M-F8E-C32	600	100-C30	65	30	65	30	100-C30	65	30	100-C30	65	30
140M-F8E-C45	600	100-C37	65	18	65	18	100-C37	65	—	100-C37	65	—
CMN-Frame												
140-CMN-2500	1000	100-C16	65	42	—	—	—	—	—	—	—	—
140-CMN-4000	1000	100-C30	65	42	—	—	—	—	—	—	—	—
140-CMN-6300	1000	100-C43	42	18	—	—	—	—	—	—	—	—
140-CMN-9000	1000	100-C72	35	10	—	—	—	—	—	—	—	—

§ For full voltage (delta) ratings above 277V or 347V, follow the NEC or CEC rules for group motor applications.



Motor Protection Circuit Breakers and Motor Circuit Protectors

Application Ratings

UL Listed Application Ratings - Motor Circuit Protectors with Bulletin 100-C Contactors§

Cat. No.	UL 508 Manual Motor Controller						UL 508 Type E (Self-Protected) Combination Motor Controller		
	Max. Fuse or C.B. per NEC	Minimum Contactor Size	Group Motor Installation		Motor Disconnect		Minimum Contactor Size	Max. Short Circuit Current [kA]	Max. Short Circuit Current [kA]
			Max. Short Circuit Current [kA]		Max. Short Circuit Current [kA]				
			480V	600V	480V	600V			
C-Frame									
140M-C2N-A16	450	100-C09	65	47	65	47	100-C09	65	47
140M-C2N-A25	450	100-C09	65	47	65	47	100-C09	65	47
140M-C2N-A40	450	100-C09	65	47	65	47	100-C09	65	47
140M-C2N-A63	450	100-C09	65	47	65	47	100-C09	65	47
140M-C2N-B10	450	100-C09	65	47	65	47	100-C09	65	47
140M-C2N-B16	450	100-C09	65	47	65	47	100-C09	65	47
140M-C2N-B25	450	100-C09	65	30	65	30	100-C09	65	—
D-Frame									
140M-D8N-B25	450	100-C09	65	30	65	30	100-C09	65	—
	—	—	—	—	—	—	100-C23	65	30
140M-D8N-B40	450	100-C09	65	30	65	30	100-C23	65	30
140M-D8N-B63	450	100-C09	65	30	65	30	100-C30	65	30
140M-D8N-C10	450	100-C09	65	30	65	30	100-C30	65	30
140M-D8N-C16	450	100-C12	65	30	65	30	100-C30	65	30
140M-D8N-C25	450	100-C23	30	30	30	30	100-C30	65	—
140M-D8N-C32	450	100-C37	65	10	65	10	—	—	—
F-Frame									
140M-F8N-C25	600	100-C23	65	30	65	30	100-C30	65	30
140M-F8N-C32	600	100-C30	65	30	65	30	100-C30	65	30
140M-F8N-C45	600	100-C37	65	18	65	18	100-C37	65	—

§ Separate overload protection is required.

* For full-voltage (delta) ratings above 277V or 347V, follow the NEC or CEC rules for group motor applications.

Motor Circuit Protectors

Application Ratings

Definition of Type 2 Short Circuit Coordination:

- The contactor or starter must not endanger persons or plant in the event of a short circuit.
- No damage to the motor protection device or other parts may occur with the exception of welding of the contactor or starter contacts if these can be easily separated without appreciable deformation (such as with a screwdriver).

In the event of short circuit, fast-opening, current-limiting Bulletin 140M Motor Protection Circuit Breakers make it possible to build economical, fully short-circuit coordinated starter combinations with Type 2 coordination.

Type 2 Coordination 400V

Cat. No.			Max. Short Circuit Current [kA]	For Use With Contactors Below (or larger)
Standard Motor Protection	High Inrush Motor Protection	Motor Circuit Protection	400V	
C-Frame				
140M-C2E-A16	—	140M-C2N-A16	100	100-C09
140M-C2E-A25	140M-C2T-A16	140M-C2N-A25	100	100-C09
140M-C2E-A40	140M-C2T-A25	140M-C2N-A40	100	100-C09
140M-C2E-A63	140M-C2T-A40	140M-C2N-A63	100	100-C09
140M-C2E-B10	140M-C2T-A63	140M-C2N-B10	100	100-C09
140M-C2E-B16	140M-C2T-B10	140M-C2N-B16	100	100-C09
140M-C2E-B25	140M-C2T-B16	140M-C2N-B25	50	100-C09
140M-C2E-B40	140M-C2T-B25	—	50	100-C09
140M-C2E-B63	140M-C2T-B40	—	50	100-C09
140M-C2E-C10	140M-C2T-B63	—	50	100-C09
140M-C2E-C16	140M-C2T-C10	—	50	100-C12*
140M-C2E-C20	140M-C2T-C16	—	50	100-C23
140M-C2E-C25	—	—	15	100-C30
140M-C2E-C29	—	—	15	100-C30
140M-C2E-C32	—	—	15	100-C37
D-Frame				
140M-D8E-B25	—	140M-D8N-B25	100	100-C09
140M-D8E-B40	—	140M-D8N-B40	100	100-C09
140M-D8E-B63	—	140M-D8N-B63	100	100-C09
140M-D8E-C10	—	140M-D8N-C10	65	100-C09
140M-D8E-C16	—	140M-D8N-C16	65	100-C12
140M-D8E-C20	140M-D8T-C16	—	65	100-C23
140M-D8E-C25	140M-D8T-C20	140M-D8N-C25	50	100-C23
140M-D8E-C29	—	—	65	100-C30
140M-D8E-C32	—	140M-D8N-C32	65	100-C37
F-Frame				
140M-F8E-C10	—	—	100	100-C09
140M-F8E-C16	—	—	100	100-C12
140M-F8E-C20	—	—	100	100-C23
140M-F8E-C25	—	140M-F8N-C25	100	100-C30
140M-F8E-C32	140M-F8T-C25	140M-F8N-C32	100	100-C30
140M-F8E-C45	140M-F8T-C32	140M-F8N-C45	100	100-C37
CMN-Frame				
140-CMN-2500	—	—	65	100-C16
140-CMN-4000	—	—	65	100-C30
140-CMN-6300	—	—	42	100-C43
140-CMN-9000	—	—	35	100-C72

* Cat. No. 100-C16 contactors Type 1 only



Type 2 Coordination 480V

Cat. No.			Max. Short Circuit Current [kA] 480V	For Use With Contactors Below (or larger)
Standard Motor Protection	High Inrush Motor Protection	Motor Circuit Protection		
C-Frame				
140M-C2E-A16	—	140M-C2N-A16	65	100-C09
140M-C2E-A25	140M-C2T-A16	140M-C2N-A25	65	100-C09
140M-C2E-A40	140M-C2T-A25	140M-C2N-A40	65	100-C09
140M-C2E-A63	140M-C2T-A40	140M-C2N-A63	65	100-C09
140M-C2E-B10	140M-C2T-A63	140M-C2N-B10	65	100-C09
140M-C2E-B16	140M-C2T-B10	140M-C2N-B16	65	100-C09
140M-C2E-B25	140M-C2T-B16	140M-C2N-B25	50	100-C16
140M-C2E-B40	140M-C2T-B25	—	50	100-C30
140M-C2E-B63	140M-C2T-B40	—	50	100-C30
140M-C2E-C10	140M-C2T-B63	—	50	100-C30
140M-C2E-C16	140M-C2T-C10	—	10	100-C30
140M-C2E-C20	140M-C2T-C16	—	10	100-C30
140M-C2E-C25	—	—	10	100-C30
140M-C2E-C29	—	—	10	100-C30
140M-C2E-C32	—	—	10	100-C37
D-Frame				
140M-D8E-B25	—	140M-D8N-B25	65	100-C09
140M-D8E-B40	—	140M-D8N-B40	65	100-C09
140M-D8E-B63	—	140M-D8N-B63	65	100-C09
140M-D8E-C10	—	140M-D8N-C10	65	100-C09
140M-D8E-C16	—	140M-D8N-C16	65	100-C12
140M-D8E-C20	140M-D8T-C16	—	65	100-C23
140M-D8E-C25	140M-D8T-C20	140M-D8N-C25	65	100-C23
140M-D8E-C29	—	—	65	100-C30
140M-D8E-C32	—	140M-D8N-C32	65	100-C37
F-Frame				
140M-F8E-C10	—	—	65	100-C09
140M-F8E-C16	—	—	65	100-C12
140M-F8E-C20	—	—	65	100-C23
140M-F8E-C25	—	140M-F8N-C25	65	100-C30
140M-F8E-C32	140M-F8T-C25	140M-F8N-C32	65	100-C30
140M-F8E-C45	140M-F8T-C32	140M-F8N-C45	65	100-C37
CMN-Frame				
140-CMN-2500	—	—	65	100-C16
140-CMN-4000	—	—	65	100-C30
140-CMN-6300	—	—	42	100-C43
140-CMN-9000	—	—	35	100-C72



Motor Circuit Protectors





Application Ratings

Type 2 Coordination 600V

Cat. No.			Max. Short Circuit Current [kA] 600V	For Use With Contactors Below (or larger)
Standard Motor Protection	High Inrush Motor Protection	Motor Circuit Protection		
C-Frame				
140M-C2E-A16	—	140M-C2N-A16	47	100-C09
140M-C2E-A25	140M-C2T-A16	140M-C2N-A25	47	100-C09
140M-C2E-A40	140M-C2T-A25	140M-C2N-A40	47	100-C09
140M-C2E-A63	140M-C2T-A40	140M-C2N-A63	47	100-C09
140M-C2E-B10	140M-C2T-A63	140M-C2N-B10	47	100-C09
140M-C2E-B16	140M-C2T-B10	140M-C2N-B16	47	100-C09
140M-C2E-B25	140M-C2T-B16	140M-C2N-B25	10	100-C16
140M-C2E-B40	140M-C2T-B25	—	10	100-C16
140M-C2E-B63	140M-C2T-B40	—	5	100-C23
140M-C2E-C10	140M-C2T-B63	—	5	100-C30
140M-C2E-C16	140M-C2T-C10	—	5	100-C30
140M-C2E-C20	140M-C2T-C16	—	5	100-C30
140M-C2E-C25	—	—	5	100-C30
140M-C2E-C29	—	—	5	100-C30
140M-C2E-C32	—	—	5	100-C37
D-Frame				
140M-D8E-B25	—	140M-D8N-B25	30	100-C30
140M-D8E-B40	—	140M-D8N-B40	30	100-C30
140M-D8E-B63	—	140M-D8N-B63	30	100-C30
140M-D8E-C10	—	140M-D8N-C10	30	100-C30
140M-D8E-C16	—	140M-D8N-C16	30	100-C30
140M-D8E-C20	140M-D8T-C16	—	5	100-C30
140M-D8E-C25	140M-D8T-C20	140M-D8N-C25	5	100-C30
140M-D8E-C29	—	—	10	100-C30
140M-D8E-C32	—	140M-D8N-C32	10	100-C37
F-Frame				
140M-F8E-C10	—	—	30	100-C30
140M-F8E-C16	—	—	30	100-C30
140M-F8E-C20	—	—	30	100-C30
140M-F8E-C25	—	140M-F8N-C25	30	100-C30
140M-F8E-C32	140M-F8T-C25	140M-F8N-C32	30	100-C30
140M-F8E-C45	140M-F8T-C32	140M-F8N-C45	10	100-C37
CMN-Frame				
140-CMN-2500	—	—	42	100-C16
140-CMN-4000	—	—	42	100-C30
140-CMN-6300	—	—	18	100-C43
140-CMN-9000	—	—	10	100-C72

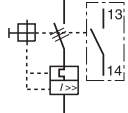
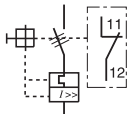
Motor Protection Circuit Breakers and Motor Circuit Protectors

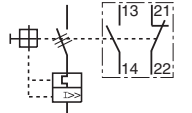
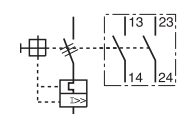
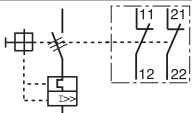
Accessories

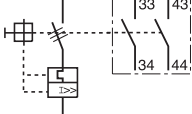
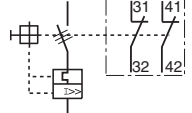
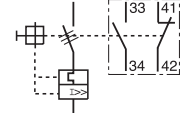
		Description			Term. No.	Description	Connection Diagram *	For Use With	Cat. No.
		Operator Position *							
		OFF	ON	Tripped					
		O	X	O	13-14	N.O. Aux		140M-C, D, F; 140U-D (UL489 only in combination with 140M-C-AFC)	140M-C-AFA10
		X	O	X	11-12	N.C. Aux			140M-C-AFA01
	Front-Mounted Auxiliary Contact • 1-pole or 2-pole • No additional space required • Only 1 per device	O	X	O	13-14	N.O. Aux		140M-C, D, F; 140U-D (UL489 only in combination with 140M-C-AFC)	140M-C-AFA11
		X	O	X	21-22	N.C. Aux			140M-C-AFA11
		O	X	O	13-14	N.O. Aux		140M-C, D, F; 140U-D (UL489 only in combination with 140M-C-AFC)	140M-C-AFA20
		O	X	O	23-24	N.O. Aux			140M-C-AFA20
		X	O	X	11-12	N.C. Aux		140M-C, D, F; 140U-D (UL489 only in combination with 140M-C-AFC)	140M-C-AFA02
		X	O	X	21-22	N.C. Aux			140M-C-AFA02
	Right Side-Mounted Auxiliary Contact • 2-pole • Adds 9 mm to the width of the device • Two per MPCB	O	X	O	33-34	N.O. Aux		140M-C, D, F	140M-C-ASA20
		O	X	O	43-44	N.O. Aux			140M-C-ASA20
		X	O	X	31-32	N.C. Aux		140M-C, D, F	140M-C-ASA02
		X	O	X	41-42	N.C. Aux			140M-C-ASA02
		O	X	O	33-34	N.O. Aux		140M-C, D, F	140M-C-ASA11
		X	O	X	41-42	N.C. Aux			140M-C-ASA11



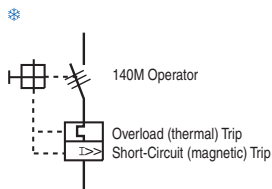





* X = Contact Closed; O = Contact Open

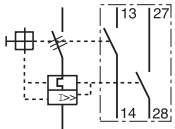
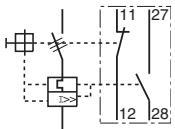
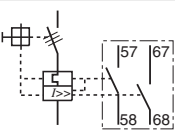
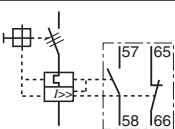

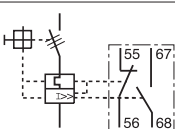
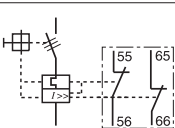
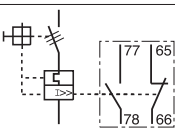
Motor Protection Circuit Breakers and Motor Circuit Protectors

Accessories

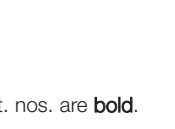
2

		Description			Term. No.	Description	Connection Diagram *	For Use With	Cat. No.
		Operator Position *							
		OFF	ON	Tripped					
	Front-Mounted Trip Contact <ul style="list-style-type: none"> • 2-pole • Indicates tripping of device • No additional space required 	O	X	O	13-14	N.O. Aux		140M-C, D, F; 140U-D (UL489 only in combination with 140M-C-AFC)	140M-C-AFAR10A10
		O	O	X	27-28	N.O. Trip (Short-Circuit & Overload)			
		X	O	X	11-12	N.C. Aux		140M-C, D, F	
		O	O	X	27-28	N.O. Trip (Short-Circuit & Overload)			
	Right-Side Mounted Trip Contact <ul style="list-style-type: none"> • 2-pole • Indicates tripping of motor protection circuit breaker • Adds 9 mm to the width of the circuit breaker • One only per MPCB • A right-side mounted auxiliary contact may be tandem mounted on top of this trip contact 	O	O	X	57-58	N.O. Trip (Short-Circuit & Overload)		140M-C, D, F	140M-C-ASAR01M10
		O	O	X	67-68	N.O. Trip (Short-Circuit)			
		X	X	O	57-58	N.O. Trip (Short-Circuit & Overload)		140M-C, D, F	
		X	X	O	65-66	N.C. Trip (Short-Circuit)			
		O	O	X	57-58	N.O. Trip (Short-Circuit & Overload)		140M-C, D, F	
		X	X	O	55-56	N.C. Trip (Short-Circuit & Overload)			
		O	O	X	67-68	N.O. Trip (Short-Circuit)		140M-C, D, F	
		X	X	O	55-56	N.C. Trip (Short-Circuit & Overload)			
		O	O	X	77-78	N.O. Trip (Short-Circuit)		140M-C, D, F	
X	X	O	65-66	N.C. Trip (Short-Circuit)		140M-C, D, F			140M-C-ASAM11

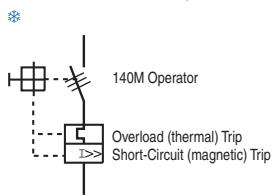

* X = Contact Closed; O = Contact Open



Motor Protection Circuit Breakers and Motor Circuit Protectors

Accessories

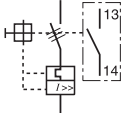
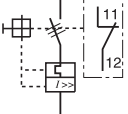
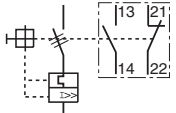
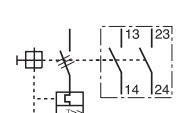
Accessories — Screwless

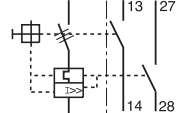
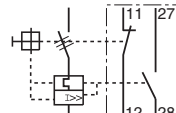
		Description			Term. No.	Description	Connection Diagram *	For Use With	Cat. No.
		Operator Position *							
		OFF	ON	Tripped					
	Front-Mounted Auxiliary Contact 1-pole or 2-pole No additional space required - Only 1 per MPCB	O	X	O	13-14	N.O. Aux		140M-C, D, F; 140M-RC	140M-RC-AFA10
		X	O	X	11-12	N.C. Aux			140M-RC-AFA01
		O	X	O	13-14	N.O. Aux		140M-C, D, F; 140M-RC	140M-RC-AFA11
		X	O	X	21-22	N.C. Aux			
		O	X	O	13-14	N.O. Aux		140M-RC-AFA20	
		O	X	O	23-24	N.O. Aux			
	Front-Mounted Trip Contact 2-pole Indicates tripping of device No additional space required	O	X	O	13-14	N.O. Aux		140M-C, D, F; 140M-RC	140M-RC-AFAR10A01
		O	O	X	27-28	N.O. Trip (Short-Circuit & Overload)			
		X	O	X	11-12	N.C. Aux		140M-RC-AFAR10A10	
		O	O	X	27-28	N.O. Trip (Short-Circuit & Overload)			

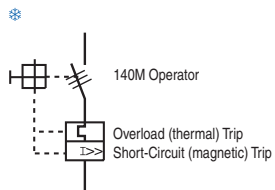

* X = Contact Closed; O = Contact Open



Motor Protection Circuit Breakers and Motor Circuit Protectors

Accessories

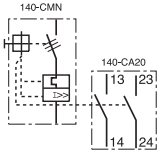
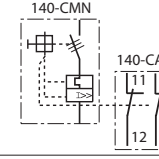
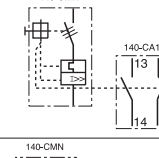
2

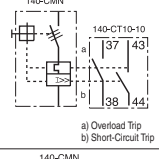
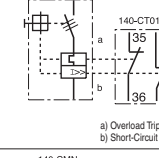
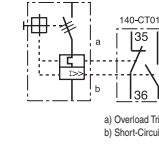
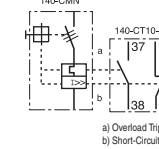



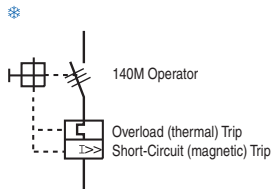

		Description			Term. No.	Description	Connection Diagram*	For Use With	Cat. No.
		Operator Position*							
		OFF	ON	Tripped					
 <p>Front-Mounted Auxiliary Contact</p> <ul style="list-style-type: none"> Internal 2-pole 1 per MPCB 	O	X	O	13-14	N.O. Aux		140-CMN	140-CA20	
	O	X	O	23-24	N.O. Aux				
	X	O	X	11-12	N.C. Aux		140-CMN	140-CA02	
	X	O	X	21-22	N.C. Aux				
	O	X	O	13-14	N.O. Aux		140-CMN	140-CA11	
	X	O	X	21-22	N.C. Aux				
 <p>Front-Mounted Trip-Indicating Auxiliary Contact</p> <ul style="list-style-type: none"> Internal 2-pole 1 per MPCB 	O	O	X	37-38	N.O. Trip (Overload)	 <p>a) Overload Trip b) Short-Circuit Trip</p>	140-CMN	140-CT10-10	
	O	O	X	43-44	N.O. Trip (Short-Circuit)				
	X	X	O	35-36	N.C. Trip (Overload)	 <p>a) Overload Trip b) Short-Circuit Trip</p>	140-CMN	140-CT01-01	
	X	X	O	41-42	N.C. Trip (Short-Circuit)				
	X	X	O	35-36	N.C. Trip (Overload)	 <p>a) Overload Trip b) Short-Circuit Trip</p>	140-CMN	140-CT01-10	
	O	O	X	43-44	N.O. Trip (Short-Circuit)				
	O	O	X	37-38	N.O. Trip (Overload)	 <p>a) Overload Trip b) Short-Circuit Trip</p>	140-CMN	140-CT10-01	
	X	X	O	41-42	N.C. Trip (Short-Circuit)				

* X = Contact Closed
O = Contact Open

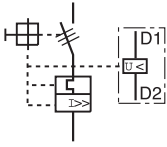

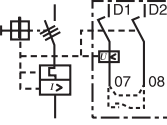
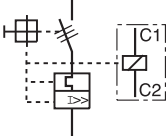
Motor Protection Circuit Breakers and Motor Circuit Protectors

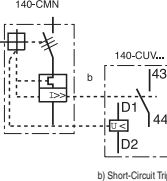
Accessories

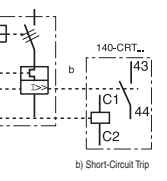

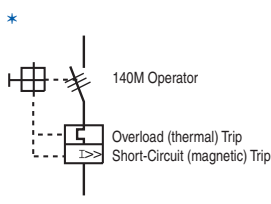







Description	Connection Diagram*	Trip Rating	For Use With	Cat. No.
 <p>Undervoltage Trip</p> <ul style="list-style-type: none"> Left-side mounted Adds 18 mm to the width of the circuit breaker Automatically trips MPCB/MCP when voltage falls below 35...70% 		24V, 60 Hz	140M-C, D, F	140M-C-UXJ
		24V, 50 Hz		140M-C-UXK
		120V, 60 Hz		140M-C-UXD
		110V, 50 Hz		140M-C-UXC
		208V, 60 Hz		140M-C-UXH
		220...230V, 50 Hz		140M-C-UXF
		240...260V, 60 Hz		140M-C-UXA
		277V, 60 Hz		140M-C-UXT
		380...400V, 50 Hz		140M-C-UXN
		480V, 60 Hz/415V, 50 Hz		140M-C-UXB
		575V, 60 Hz/500V, 50 Hz		140M-C-UXM
		600V, 60 Hz		140M-C-UXVC
		 <p>Undervoltage Trip</p> <ul style="list-style-type: none"> Left-side mounted 2 early make contacts integrated Adds 18 mm to the width of the circuit breaker Automatically trips MPCB/MCP when voltage falls below 35...70% 		
24V, 50 Hz	140M-C-UCK			
120V, 60 Hz	140M-C-UCD			
110V, 50 Hz	140M-C-UCC			
208V, 60 Hz	140M-C-UCH			
220...230V, 50 Hz	140M-C-UCF			
240...260V, 60 Hz	140M-C-UCA			
277V, 60 Hz	140M-C-UCT			
380...400V, 50 Hz	140M-C-UCN			
480V, 60 Hz/415V, 50 Hz	140M-C-UCB			
575V, 60 Hz/500V, 50 Hz	140M-C-UCM			
600V, 60 Hz	140M-C-UCVC			
<p>Shunt Trip</p> <ul style="list-style-type: none"> Left-side mounted Adds 18 mm to the width of the circuit breaker Provides remote tripping of the MPCB/MCP 			24V, 60 Hz	
		24V, 50 Hz	140M-C-SNK	
		110V, 50 Hz/120V, 60 Hz	140M-C-SND	
		208V, 60 Hz	140M-C-SNH	
		220...230V, 50 Hz	140M-C-SNF	
		240...260V, 60 Hz	140M-C-SNA	
		277V, 60 Hz	140M-C-SNT	
		380...400V, 50 Hz	140M-C-SNN	
		480V, 60 Hz/415V, 50 Hz	140M-C-SNB	
		575V, 60 Hz/500V, 50 Hz	140M-C-SNM	
		600V, 60 Hz	140M-C-SNVC	
		24V DC	140M-C-SNZJ	
		 <p>Undervoltage Trip Unit</p> <ul style="list-style-type: none"> Internal, front-mounted Integrated short-circuit trip indication Automatically trips MPCB when voltage falls below 35...70% 	 <p>b) Short-Circuit Trip</p>	24V, 50/60 Hz
110V, 50 Hz/120V, 60 Hz	140-CUV-D			
220V, 50 Hz/240V, 60 Hz	140-CUV-A			
 <p>Shunt Trip Unit</p> <ul style="list-style-type: none"> Internal, front-mounted Integrated short-circuit trip indication Provides remote tripping of the MPCB 	 <p>b) Short-Circuit Trip</p>	24V, 50/60 Hz	140-CMN	140-CRT-KJ
		110V, 50 Hz/120V, 60 Hz		140-CRT-D
		220V, 50 Hz/240V, 60 Hz		140-CRT-A



Motor Protection Circuit Breakers and Motor Circuit Protectors

Accessories











2

Description		For Use With	Cat. No.	
	Anti-Tamper Shield Provides protection against inadvertent adjustment of the current setting	10 pcs/pkg	140M-C, D, F	140M-C-CA
	Lockable Twist Knob • For one padlock 4...6 mm (3/16 in.) Ø shackle • Can be locked in OFF position	Black	140M-C, D, F; 140U-D	140M-C-KN1
		Red/Yellow		140M-C-KRY1
	Locking Tag • Padlock attachment to the lockable handles • Up to three padlocks 4...8 mm (5/16 in.) Ø shackle		140M-C-KN1, 140M-C-KRY1	140M-C-M3
	Padlockable Operating Knob • Accepts 8 mm (5/16 in.) Ø padlock shackle — up to three padlocks • Permits padlocking in the off position	Black	140-CMN	140-KN
		Red/Yellow		140-KRY
	Door Coupling Handle • For 3 padlocks 4...8 mm (5/16 in.) in diameter • IP66 Protection/Type 1, 4, 4X, 12 • Interlock override capability • Can be modified for locking in ON position • Ships with coupling — order extension shaft and legend plate separately • Mounting depth (front of DIN Rail to front of enclosure door): - 140M-C: 105.5 mm ± 5 mm (4.15 in. ± 3/16 in.) - 140M-D: 114.5 mm ± 5 mm (4.5 in. ± 3/16 in.) - 140M-F: 137.1 mm ± 5 mm (5.4 in. ± 3/16 in.) - 140-CMN: 169 mm +/- 5 mm (6.7 in. +/- 3/16 in.)	Black	140M-C, D, F	140M-C-DN66
			140-CMN	140-CDN66
		Red/Yellow	140M-C, D, F	140M-C-DRY66
			140-CMN	140-CDRY66
	Legend Plate • Marking: "Hauptschalter" and "Main Switch" • Marking: "Not-Aus" and "Emergency Off"		140-CDN66	140M-C-DFCN
			140-CDRY66	140M-C-DFCRY
	Extension Shaft Cut to required length for mounting depth (front of DIN Rail to front of enclosure door): - 140M-C: 117...338 mm (4.6...13.3 in.) - 140M-D: 126...347 mm (5.0...13.7 in.) - 140M-F: 149...369 mm (5.9...14.5 in.) - 140-CMN: 180...403 mm (7.1...15.9 in.)		140M-C-DN66, 140M-C-DRY66, 140-CDN66, 140-CDRY66	140M-C-DS
	Extension Shaft (Extended Length) Cut to required length for mounting depth (front of DIN Rail to front of enclosure door): - 140M-C: 117...488 mm (4.6...19.2 in.) - 140M-D: 126...497 mm (5.0...19.6 in.) - 140M-F: 149...519 mm (5.9...20.4 in.) - 140-CMN: 180...553 mm (7.1...21.8 in.)		140M-C-DN66, 140M-C-DRY66, 140-CDN66, 140-CDRY66	140M-C-DSL
	Coupler Included with Cat. Nos. 140M-C-DN66 and 140M-C-DRY66		140M-C, D, F; 140U-D	140M-C-DNC
	IP65 Non-Metallic Enclosure • Knockouts for M20 and M25 fittings • Suitable for flexible cable with internal ground wire or conduit when externally grounded around the outside of the enclosure (no UL/CSA approval)	Black Handle	140M-C	198E-AYTG2
		Red/Yellow Handle	140M-C	198E-AYTJ2
	Screw Adapter • For screw arrangement of a motor protection circuit breaker	10 pcs/pkg	140M-C, D, F; 140U-D	140M-C-N45

Motor Protection Circuit Breakers and Motor Circuit Protectors

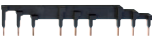
Accessories

2

	Description	For Use With	Cat. No.
	ECO Connecting Module — 12 A • For DOL and reversing starters • Eco-starters mount on single DIN Rail (140M on DIN Rail) • Electrical and mechanical interconnection of 140M and 100-K contactors	140M-C to 100-K	140M-C-PEK12
	ECO Connecting Modules — 25 A • Eco-starters mount on single DIN Rail (140M on DIN Rail) • Electrical and mechanical interconnection of 140M MPCB and 100-C (with AC coils or 24V DC electronic coils) contactors	140M-C to 100-C09...C23	140M-C-PEC23
		140M-D to 100-C09...C23	140M-D-PEC23
	ECO Connecting Modules — 25 A • Eco-starters mount on single DIN Rail (100-C on DIN Rail) • Electrical and mechanical interconnection of 140M MPCB and 100-C (with AC or DC coils)	140M-C, 140M-D to 100-C09...C23	140M-C-PEC23A
	Connecting Modules — 25 and 45 A • Contactor and MPCB MUST BE mounted separately on (2) DIN Rails • Electrical and mechanical interconnection of 140M and 100-C (with AC coils)	140M-C to 100-C09...C23	140M-C-PNC23
		140M-D to 100-C09...C23	140M-D-PNC23
140M-D to 100-C30...C37		140M-D-PNC37	
140M-F to 100-C30...C37		140M-F-PNC37	
Coil Modules — 25 A and 45 A • For use with Bulletin 103T/107T 3-component starters	140M-C, -D to 100-C09...C23	140M-C-PSC23	
	140M-D, -F to 100-C30...C43	140M-F-PSC43	
	Spacing Adapter • Required for self-protected combination motor controller (Type E) applications of Bul. 140M-C, -D, and -F MPCBs. Not for use with bus bars.	140M-C, -D	140M-C-TE1
		140M-F	140M-F-TE
	Feeder Block for Compact Busbar • Supply of compact busbars • Increases terminal capacity	140M-C	140M-C-WBE
		140M-F	140M-F-WBE
	Feeder Terminal for Compact Busbar • For supply of compact busbars • Top feed — overlaps compact busbar • Meets IEC spacing requirements	140M-C, -D	140M-C-WTN
	Feeder Terminal for Compact Busbar • For supply of compact busbars • Top feed — overlaps compact busbar • Meets UL Type E spacing requirements	140M-C, -D	140M-C-WTEN
		140M-F	140M-F-WTE
	Three-Phase Compact Busbar for 32 A Motor Protection Circuit Breakers — 64 A Max. Continuous Current • 45 mm spacing • For use with front-mounted auxiliary contact	2 connections	140M-C-W452N
		3 connections	140M-C-W453N
		4 connections	140M-C-W454N
		5 connections	140M-C-W455N
	Three-Phase Compact Busbar for 32 A Motor Protection Circuit Breakers — 64 A Max. Continuous Current • 54 mm spacing • For use with side-mounted auxiliary contact	2 connections	140M-C-W542N
		3 connections	140M-C-W543N
		4 connections	140M-C-W544N
		5 connections	140M-C-W545N
	Three-Phase Compact Busbar for 45 A Motor Protection Circuit Breakers — 115 A Max. Continuous Current • 54 mm spacing • For use with front-mounted auxiliary contact	2 connections	140M-F-W542
		3 connections	140M-F-W543
		4 connections	140M-F-W544
	Three-Phase Compact Busbar for 45 A Motor Protection Circuit Breakers — 115 A Max. Continuous Current • 63 mm spacing • For use with side-mounted auxiliary contact	2 connections	140M-F-W632
3 connections		140M-F-W633	
4 connections		140M-F-W634	
	Terminal Cover • For covering of unused compact bus bar terminals • IP2X finger protection	140M-C, 140M-D	140M-C-WSN
		140M-F	140M-F-WS
	Top Hat Rail Adapter — 10 mm • Adjusts the depth of the 140M-C to the 140M-D • Allows the use of compact busbars across both frame sizes • Must be ordered in multiples of 10	140M-C	140-KBH2

Notes: 1. See Bulletin 140U for Internal and External Accessories for Bulletin 140M-H, J, L and N frames.

2. Bulletin 140M-I frame Accessories such as auxiliaries, alarms, undervoltage and shunt trips are only available as factory installed modifications. See page 2-37.

Motor Protection Circuit Breakers and Motor Circuit Protectors

Accessories





2

Description		For Use With	Pkg. Quantity	Cat. No.
	Terminal End Cover — 0.25 in.	140M-I	1	140U-I-TC2
	Terminal End Cover — 0.41 in.			140U-I-TC4
	Terminal Shields (Plastic) IP20 Ingress Protection	140M-I	1	140U-I-TS1
	Padlockable Handle Lock Hasp — Off only Padlocking Hasp Lock-OFF only	140M-I	1	140U-I-PL
	End Cap Kit Provides 3-phase connections for terminal or bolt-on connections Metric Hardware	140M-I	1	140U-I-ECM
	Phase Barriers Provides additional phase clearance when special connections are required	140M-I	2	140U-I-PB
	Terminal Lugs Steel Terminal Copper/Aluminum wire #4-4/0 AWG	140M-I	3	140U-I-TLS1
	Terminal Lugs Stainless Steel Terminal Copper/Aluminum wire #4-4/0 AWG			140U-I-TLS2
	Rotary Close Couple Handle International Black handle	140M-I	1	140U-I-RCB
	Rotary Close Couple Handle International Red/Yellow handle			140U-I-RCR
	Operating Mechanism for External Handles	140M-I	1	198-H2
	External Handles Black/Grey IP66 (Type 3/3R/4/4X/12)	140M-I	1	190-HM4
	Red/Yellow IP66 (Type 3/3R/4/4X/12)			190-HM4E
	Black/Grey IP55 (Type 1)			190-HM1
	Red/Yellow IP55 (Type 1)			190-HM1E
	Overload Pre-trip Auxiliary Contact (AX) Opens contactor coil circuit on overload before MPCB trips (Automatic reset)	140M-J, -L (MPCB only)	1	140U-J-ER1RX



Motor Protection Circuit Breakers and Motor Circuit Protectors

Accessories

Description		For Use With	Pkg. Quantity	Cat. No.	
	Extension Shafts	140M-I	5	194R-R3	
	Standard Enclosure Working Depth [mm (in.)]				
	Minimum 203 (8)				
	Maximum 305 (12)				
	Extended				
	Minimum 203 (8)				
Maximum 508 (20)					
	Flex-Cable Operating Mechanism NEMA Type 1/3/12/4/4X Flange-Mount Handle	140M-I	1	140U-I-FCX03	
				3 ft. (0.9 m) Cable	140U-I-FCX04
				4 ft. (1.2 m) Cable	140U-I-FCX06
				6 ft. (1.9 m) Cable	140U-I-FCX10
	10 ft. (3.0 m) Cable			140U-I-FCS03	
	Flex-Cable Operating Mechanism Stainless Steel - Type 4/4X Flange Mount Handle			3 ft. (0.9 m) Cable	140U-I-FCS04
				4 ft. (1.2 m) Cable	140U-I-FCS06
				6 ft. (1.9 m) Cable	140U-I-FCS10
				10 ft. (3.0 m) Cable	
				DIN (#3) symmetrical hat rail 35 x 7.5 x 1 m	140M-D 140M-F 100-C all
	DIN (#3) Symmetrical Rail 35 mm x 15 mm x 1 m long Top Hat Rail (DIN #3 Symmetrical Rail)	140M-C 140M-D 140M-F 140-CMN	5 pcs/kg	1492-DR9	



Motor Protection Circuit Breakers and Motor Circuit Protectors

Modifications

140M Factory Modifications (Open)

Note: For modifications add (option code _) for desired features to cat. no. Available in North America only.

2

f

Miscellaneous		
Code	Description	Frame Size
KN(1)	Black Lockable Knob	C, D, F, CMN
KRY(1)	Red/Yellow Lockable Knob	C, D, F, CMN
TE(1)	Spacing Adapter for Self-Protected Starters (Type E)	C, D, F
MT	STD Bus Bar Mount, Top	C, D, F, H, CMN
MU	STD Bus Bar Mount, Universal	J, K, L

g

Aux / Trip Contacts - C, D, F			
1st Code	Description	2nd Code	Description
Bottom Front		Right Side	
X	Placeholder	X	Placeholder
A	1 N.C.	C	1 N.O. + 1 N.C.
B	1 N.O.	D	2 N.O.
C	1 N.O. + 1 N.C.	E	2 N.C.
D	2 N.O.	K	1 N.C. (SC+OL) + 1 N.C. (SC)
E	2 N.C.	L	1 N.O. (SC+OL) + 1 N.O. (SC)
R	1 N.C. + 1 N.O. (SC+OL)	M	1 N.C. (SC+OL) + 1 N.O. (SC)
S	1 N.O. + 1 N.O. (SC+OL)	N	1 N.O. (SC+OL) + 1 N.C. (SC)
		Q	1 N.O. (SC) + 1 N.C. (SC)

g

Aux / Trip Contacts - CMN			
1st Code	Description	2nd Code	Description
Bottom Front		Top Front†	
X	Placeholder	X	Placeholder
C	1 N.O. + 1 N.C.	K	1 N.C. (OL) + 1 N.C. (SC)
D	2 N.O.	L	1 N.O. (OL) + 1 NO (SC)
E	2 N.C.	M	1 N.C. (OL) + 1 N.O. (SC)
		N	1 N.O. (OL) + 1 N.C. (SC)

† Cannot be combined with option "h".

g

Aux / Trip Contacts - H, J, L			
1st Code	Description	2nd Code	Description
Bottom Front		Right Side	
X	Placeholder	X	Placeholder
		C	1 N.O. + 1 N.C.
		R*	1 N.O. + 1 N.C. (Overload Function)
		F*	2 N.O. + 2 N.C.
		N*	1 N.O. (SC+OL) + 1 N.C. (SC)
		T*	1 N.O. + 1 N.C. and 1 N.O. + 1 N.C. (SC+OL)

* Only available on MCPs.
* J- and L-Frame MPCB only.

g

Aux / Trip Contacts - I, N			
1st Code	Description	2nd Code	Description
Left Side		Right Side	
X	Placeholder	X	Placeholder
C	1 N.O. + 1 N.C.	C	1 N.O. + 1 N.C.
F	2 N.O. + 2 N.C.	F*	2 N.O. + 2 N.C.
N	1 N.O. (SC+OL) + 1 N.C. (SC)	N*	1 N.O. (SC+OL) + 1 N.C. (SC)
T	1 N.O. + 1 N.C. and 1 N.O. + 1 N.C. (SC+OL)	T*	1 N.O. + 1 N.C. and 1 N.O. + 1 N.C. (SC+OL)

* Only available on MCPs.

h

UV and Shunt Trips - C, D, F			
1st Code	Description	2nd Code	Description
Left Side		Voltage	
G	Undervoltage Trip	J	24V AC, 60 Hz
P	Shunt Trip	K	24V AC, 50 Hz
		D	120V AC, 60 Hz
		C	110V AC, 50 Hz
		H	208V AC, 60 Hz
		F	220...230V AC, 50 Hz
		A	240V AC, 60 Hz
		T	277V AC, 60 Hz
		N	380...400V AC, 50 Hz
		B	480V AC, 60 Hz and 415V AC, 50 Hz
		VC	600V AC, 60 Hz
		M	575V AC, 60 Hz and 500V AC, 50 Hz
		ZR	9V DC
		ZQ	12V DC
		ZJ	24V DC
		ZW	36V DC
		ZY	48V DC
		ZZ	60V DC
		ZB	64V DC
ZG	72V DC		
ZE	80V DC		



Motor Protection Circuit Breakers and Motor Circuit Protectors

Modifications

140M Factory Modifications (Open)

Note: For modifications add (option code _) for desired features to cat. no. Available in North America only.

h

UV and Shunt Trips - CMN			
1st Code	Description	2nd Code	Description
Top Front‡		Voltage	
G	Undervoltage Trip	KJ	24V AC, 60 Hz and 24V AC, 50 Hz
P	Shunt Trip	D	120V AC, 60 Hz and 110V AC, 50 Hz
		A	240V AC, 60 Hz and 220...230V AC, 50 Hz

‡Cannot be combined with option "g".

h

UV and Shunt Trips - H, J, L			
1st Code	Description	2nd Code	Description
Left Front		UV Voltage	
G	Undervoltage Trip	J	24V AC/DC
		D	110...127V AC
		A	208...240V AC
		B	380...500V AC
Left Front		Shunt Voltage	
P	Shunt Trip	J	12...60V AC/DC
		D	110...240V AC/DC
		B	380...600V AC

h

UV and Shunt Trips - I			
1st Code	Description	2nd Code	Description
Left Front		UV Voltage	
G	Undervoltage Trip	J	24V AC
		D	110...127V AC
		A	208...240V AC
		B	380...480V AC
Left Front		Shunt Voltage	
P	Shunt Trip	J	12...24V AC/DC
		D	48...127V AC and 48...60V DC
		N	208...380V AC and 110...127V DC
		B	415...600V AC and 220...250V DC

h

UV and Shunt Trips - N			
1st Code	Description	2nd Code	Description
Left Front		UV Voltage	
G	Undervoltage Trip	J	24V AC
		D	110...127V AC
		A	208...240V AC
		B	380...480V AC
Left Front		Shunt Voltage	
P	Shunt Trip	J	12...24V AC/DC
		D	110...240V AC and 110...125V DC
		N	380...440V AC and 220...250V DC
		B	480...600V AC



Motor Protection Circuit Breakers and Motor Circuit Protectors Specifications

IEC Performance Data

		Cat. No. 140M-C2E-														
		A16	A25	A40	A63	B10	B16	B25	B40	B63	C10	C16	C20	C25	C29	C32
Rated Operational Current, I_e	[A]	0.16	0.25	0.4	0.63	1	1.6	2.5	4	6.3	10	16	20	25	29	32
Magnetic Release Current	[A]	2.1	3.3	5.2	8.2	13	21	33	52	82	130	208	260	325	406	448

Switching of Standard Three-Phase Motors

AC-3																
230/240V	[kW]	—	—	0.06	0.09	0.18	0.25	0.37	0.75	1.5	2.2	4.0	5.5	5.5	7.5	7.5
400/415V	[kW]	0.02	0.04	0.09	0.18	0.25	0.55	0.75	1.5	2.2	4.0	7.5	10	11	13	15
500V	[kW]	0.06	0.09	0.12	0.18	0.37	0.75	1.1	2.2	3.0	6.3	10	11	15	18.5	20
690V	[kW]	0.06	0.09	0.18	0.25	0.55	1.1	1.8	3.0	4.0	7.5	13	17	22	25	25

Back-Up Fuses

gG, gL, only if $I_{cc} \geq I_{cu}$

230/240V	[A]	*	*	*	*	*	*	*	*	*	*	*	*	100	100	125	125
400/415V	[A]	*	*	*	*	*	*	*	*	*	*	*	80	100	100	125	125
440/460V	[A]	*	*	*	*	*	*	*	*	*	*	63	80	80	80	100	100
500V	[A]	*	*	*	*	*	*	*	*	*	*	80	80	80	80	100	100
690V	[A]	*	*	*	*	*	16	20	35	50	50	63	63	63	80	80	

Ultimate Short Circuit Breaking Capacity

I_{cu}

230/240V	[kA]	100	100	100	100	100	100	100	100	100	100	100	100	65	65	50	50
400/415V	[kA]	100	100	100	100	100	100	100	100	100	100	100	65	50	15	15	15
440/460V	[kA]	100	100	100	100	100	100	100	100	100	100	50	10	6	6	6	6
500V	[kA]	100	100	100	100	100	100	100	100	100	100	50	10	6	6	6	6
690V	[kA]	100	100	100	100	100	8	8	8	4	4	3	3	3	3	3	3

Rated Service Short Circuit Breaking Capacity

I_{cs}

230/240V	[kA]	100	100	100	100	100	100	100	100	100	100	100	100	50	50	25	25
400/415V	[kA]	100	100	100	100	100	100	100	100	100	100	100	50	15	15	15	15
440/460V	[kA]	100	100	100	100	100	100	100	100	100	100	50	6	6	6	6	6
500V	[kA]	100	100	100	100	100	100	100	100	100	100	50	6	6	6	6	6
690V	[kA]	100	100	100	100	100	8	8	8	4	4	3	3	3	3	3	3

* No back-up fuse required.

Motor Protection Circuit Breakers and Motor Circuit Protectors

Specifications

IEC Performance Data, Continued

		Cat. No. 140M-D8E-									Cat. No. 140M-F8E-					
		B25	B40	B63	C10	C16	C20	C25	C29	C32	C10	C16	C20	C25	C32	C45
Rated Operational Current, I_e	[A]	2.5	4.0	6.3	10	16	20	25	29	32	10	16	20	25	32	45
Magnetic Release Current	[A]	33	52	82	130	208	260	325	406	448	130	208	260	325	416	585
Switching of Standard Three-Phase Motors																
AC-3																
230/240V	[kW]	0.37	0.75	1.5	2.2	4.0	5.5	5.5	7.5	7.5	2.2	4.0	5.5	6.3	7.5	13
400/415V	[kW]	0.75	1.5	2.2	4.0	7.5	10	11	13	15	4.0	7.5	10	11	15	22
500V	[kW]	1.1	2.2	3.0	6.3	10	11	15	18.5	20	6.3	10	11	15	20	30
690V	[kW]	1.8	3.0	4.0	7.5	13	17	22	25	25	7.5	13	17	22	30	40
Back-Up Fuses																
gG, gL, only if $I_{cc} \geq I_{cu}$																
230/240V	[A]	*	*	*	*	*	*	*	*	*	*	*	*	*	*	*
400/415V	[A]	*	*	*	*	*	100	100	125	125	80	100	100	100	125	125
440/460V	[A]	*	*	*	*	80	100	100	125	125	80	100	100	100	125	125
500V	[A]	*	*	*	*	80	80	80	100	100	80	100	100	100	125	125
690V	[A]	20	35	50	50	63	63	63	80	80	63	80	80	80	100	100
Ultimate Short Circuit Breaking Capacity																
I_{cu}																
230/240V	[kA]	100	100	100	100	100	100	100	65	65	100	100	100	100	100	100
400/415V	[kA]	100	100	100	100	100	100	65	50	50	100	100	100	100	65	65
440/460V	[kA]	100	100	100	100	50	50	50	25	25	65	65	65	65	65	50
500V	[kA]	100	100	100	100	50	50	50	25	25	50	50	50	50	50	50
690V	[kA]	10	10	10	6	6	6	6	6	6	10	10	10	10	10	10
Rated Service Short Circuit Breaking Capacity																
I_{cs}																
230/240V	[kA]	100	100	100	100	100	100	100	50	50	100	100	100	100	100	100
400/415V	[kA]	100	100	100	100	50	25	25	25	25	50	50	50	50	50	50
440/460V	[kA]	100	100	100	100	50	25	25	20	20	50	50	50	50	50	50
500V	[kA]	100	100	100	100	50	25	25	20	20	50	50	50	50	50	50
690V	[kA]	10	10	10	6	4	4	4	4	4	10	10	10	10	6	6

* No back-up fuse required.

Motor Protection Circuit Breakers and Motor Circuit Protectors

Specifications

IEC Performance Data, Continued

Cat. No.	140-CMN-...				
	-2500	-4000	-6300	-9000	
Rated Operational Current, I_e [A]	25	40	63	90	
Magnetic Release Current [A]	350	560	890	1260	
Switching of Standard Three-Phase Motors					
AC-3					
230/240V*	[kW]	5.5/7.5	10/11	13/20	22/25
400/415V*	[kW]	7.5/13	15/22	25/32	37/45
500V*	[kW]	11/15	18.5/25	30/40	45/55
690V*	[kW]	15/22	25/30	37/55	63/75
Back-up fuses					
gG, gL-, only if $I_{cc} \geq I_{cu}$					
230/240V	[A]	*	*	*	*
400/415V	[A]	160	160	160	160
500V	[A]	160	160	160	160
690V	[A]	160	160	160	160
Ultimate short-circuit breaking capacity I_{cu}					
230/240V	[kA]	100	100	100	100
400/415V	[kA]	65	65	65	50
500V	[kA]	50	30	30	25
690V	[kA]	15	8	8	6
Rated service short-circuit breaking capacity I_{cs}					
230/240V	[kA]	100	100	100	100
400/415V	[kA]	65	50	50	25
500V	[kA]	50	25	25	13
690V	[kA]	15	8	6	6

* No back-up fuse required.

* Power ratings: Preferred values according to IEC 60072-1.



Motor Protection Circuit Breakers and Motor Circuit Protectors

Specifications

IEC Performance Data, Continued

	Cat. No. 140M-C2N-						
	A16	A25	A40	A63	B10	B16	B25
Rated Operational Current, I_e [A]	0.16	0.25	0.4	0.63	1	1.6	2.5
Magnetic Release Current [A]	2.1	3.3	5.2	8.2	13	21	32
Switching of Standard Three-Phase Motors							
AC-3							
230/240V [kW]	—	—	0.06	0.09	0.18	0.25	0.37
400/415V [kW]	0.02	0.04	0.09	0.18	0.25	0.55	0.75
500V [kW]	0.06	0.09	0.12	0.18	0.37	0.75	1.1
690V [kW]	0.06	0.09	0.18	0.25	0.55	1.1	1.8
Back-Up Fuses							
gG, gL, only if $I_{cc} \geq I_{cu}$ *							
230/240V [A]	*	*	*	*	*	*	*
400/415V [A]	*	*	*	*	*	*	*
440/460V [A]	*	*	*	*	*	*	*
500V [A]	*	*	*	*	*	*	*
690V [A]	*	*	*	*	*	16	20
Ultimate Short Circuit Breaking Capacity							
I_{cu}							
230/240V [kA]	100	100	100	100	100	100	100
400/415V [kA]	100	100	100	100	100	100	100
440/460V [kA]	100	100	100	100	100	100	100
500V [kA]	100	100	100	100	100	100	100
690V [kA]	100	100	100	100	100	10	8
Rated Service Short Circuit Breaking Capacity							
I_{cs}							
230/240V [kA]	100	100	100	100	100	100	100
400/415V [kA]	100	100	100	100	100	100	100
440/460V [kA]	100	100	100	100	100	100	100
500V [kA]	100	100	100	100	100	100	100
690V [kA]	100	100	100	100	100	8	8

* No back-up fuse required.

Motor Protection Circuit Breakers and Motor Circuit Protectors

Specifications

IEC Performance Data, Continued

	Cat. No. 140M-D8N-							Cat. No. 140M-F8N-		
	B25	B40	B63	C10	C16	C25	C32	C25	C32	C45
Rated Operational Current, I_e [A]	2.5	4.0	6.3	10	16	25	32	25	32	45
Magnetic Release Current [A]	32	52	82	130	208	325	448	325	416	585
Switching of Standard Three-Phase Motors										
AC-3										
230/240V [kW]	0.37	0.75	1.5	2.2	4.0	5.5	7.5	6.3	7.5	13
400/415V [kW]	0.75	1.5	2.2	4.0	7.5	11	15	11	15	22
500V [kW]	1.1	2.2	3.0	6.3	10	15	20	15	20	30
690V [kW]	1.8	3.0	4.0	7.5	13	22	25	22	30	40
Back-Up Fuses										
gG, gL, only if $I_{cc} \geq I_{cu}$										
230/240V [A]	*	*	*	*	*	*	*	100	125	125
400/415V [A]	*	*	*	*	*	100	125	100	125	125
440/460V [A]	*	*	*	*	80	100	125	100	125	125
500V [A]	*	*	*	*	80	80	100	100	125	125
690V [A]	20	35	50	50	63	63	80	80	100	100
Ultimate Short Circuit Breaking Capacity										
I_{cu}										
230/240V [kA]	100	100	100	100	100	100	65	100	100	100
400/415V [kA]	100	100	100	100	100	65	50	100	65	65
440/460V [kA]	100	100	100	100	50	50	25	65	65	50
500V [kA]	100	100	100	100	50	25	25	50	50	50
690V [kA]	10	10	10	6	6	6	6	10	10	10
Rated Service Short Circuit Breaking Capacity										
I_{cs}										
230/240V [kA]	100	100	100	100	100	100	50	100	100	100
400/415V [kA]	100	100	100	100	50	25	25	50	50	50
440/460V [kA]	100	100	100	100	50	25	20	50	50	50
500V [kA]	100	100	100	100	50	25	20	50	50	50
690V [kA]	10	10	10	6	4	4	4	10	6	6

* No back-up fuse required.

Motor Protection Circuit Breakers and Motor Circuit Protectors

Specifications

IEC Performance Data, Continued

	Cat. No. 140M-C2T-											
	A16	A25	A40	A63	B10	B16	B25	B40	B63	C10	C16	
Rated Operational Current, I_e [A]	0.16	0.25	0.40	0.63	1.0	1.6	2.5	4.0	6.3	10	16	
Magnetic Release Current [A]	3.2	5.2	8.2	13	21	32	52	82	130	208	260	
Switching of Standard Three-Phase Motors												
AC-3												
230/240V [kW]	—	—	0.06	0.09	0.18	0.25	0.37	0.75	1.5	2.2	4.0	
400/415V [kW]	0.02	0.04	0.09	0.18	0.25	0.55	0.75	1.5	2.2	4.0	7.5	
500V [kW]	0.06	0.09	0.12	0.18	0.37	0.75	1.1	2.2	3.0	6.3	10	
690V [kW]	0.06	0.09	0.18	0.25	0.55	1.1	1.8	3.0	4.0	7.5	13	
Back-Up Fuses												
gG, gL, only if $I_{cc} \geq I_{cu}$												
230/240V [A]	*	*	*	*	*	*	*	*	*	*	*	
400/415V [A]	*	*	*	*	*	*	*	*	*	*	80	
440/460V [A]	*	*	*	*	*	*	*	*	*	*	63	
500V [A]	*	*	*	*	*	*	*	*	*	*	80	
690V [A]	*	*	*	*	*	16	20	35	50	50	63	
Ultimate Short Circuit Breaking Capacity												
I_{cu}												
230/240V [kA]	100	100	100	100	100	100	100	100	100	100	100	
400/415V [kA]	100	100	100	100	100	100	100	100	100	100	50	
440/460V [kA]	100	100	100	100	100	100	100	100	100	100	10	
500V [kA]	100	100	100	100	100	100	100	100	100	100	10	
690V [kA]	100	100	100	100	100	8	8	8	4	4	3	
Rated Service Short Circuit Breaking Capacity												
I_{cs}												
230/240V [kA]	100	100	100	100	100	100	100	100	100	100	100	
400/415V [kA]	100	100	100	100	100	100	100	100	100	100	15	
440/460V [kA]	100	100	100	100	100	100	100	100	100	50	6	
500V [kA]	100	100	100	100	100	100	100	100	100	50	6	
690V [kA]	100	100	100	100	100	8	8	8	4	4	3	

* No back-up fuse required.

Motor Protection Circuit Breakers and Motor Circuit Protectors

Specifications

IEC Performance Data, Continued

	Cat. No. 140M-D8T-		Cat. No. 140M-F8T-	
	C16	C20	C25	C32
Rated Operational Current, I_e [A]	16	20	25	32
Magnetic Release Current [A]	260	325	416	585
Switching of Standard Three-Phase Motors				
AC-3				
230/240V * [kW]	4.0	5.5	6.3	7.5
400/415V * [kW]	7.5	10	11	15
500V * [kW]	10	11	15	20
690V * [kW]	13	17	22	30
Back-up fuses				
gG, gL, only if $I_{cc} \geq I_{cu}$				
230/240V [A]	*	*	*	*
400/415V [A]	80	100	100	125
440/460V [A]	80	100	100	125
500V [A]	80	80	100	125
690V [A]	63	63	80	100
Ultimate short-circuit breaking capacity				
I_{cu}				
230/240V [kA]	100	100	100	100
400/415V [kA]	100	65	65	65
440/460V [kA]	50	25	65	65
500V [kA]	50	25	50	50
690V [kA]	6	6	10	10
Rated service short-circuit breaking capacity I_{cs}				
I_{cs}				
230/240V [kA]	100	100	100	100
400/415V [kA]	25	25	50	50
440/460V [kA]	25	25	50	50
500V [kA]	25	25	50	50
690V [kA]	4	4	6	6

* No back-up fuse required.

* Consult your local Rockwell Automation sales office or Allen-Bradley distributor.



Bulletin 140M

Motor Protection Circuit Breakers and Motor Circuit Protectors

Specifications

General Data

Cat. No.	140M-C	140M-D	140M-F	140M-F	140-CMN
Rated Insulation Voltage U_i					
IEC, SEV, VDE 0660	[V]	690			690
UL, CSA	[V]	600			600
Rated Impulse Withstand Voltage U_{imp}					
Pollution degree		3			3
Main circuits U_{imp} /Overvoltage Category		6 kV/III			6 kV/III
Auxiliary circuits U_{imp} /Overvoltage Category		6 kV/III			6 kV/III
Rated Frequency	[Hz]	50/60			40...60
Utilization Category					
IEC 60947-2 (Circuit breaker)		A			A
IEC 60947-4-1 (Motor starter)		AC-3			AC-3
Life Span					
Mechanical	[operations]	100 000		30 000	30 000
Electrical (I_e max.)	[operations]	100 000		30 000	10 000 (up to 63 A) 5 000 (up to 90 A)
Switching Frequency	[operations/h]	max. 25			max. 20
Ambient Temperature					
Storage	[°C]	-40 ... +80			-25... +80
Operation	[°C]	-25... +60			
Climatic resistance					
Moisture change climate (600068-2-30)		23 °C / 83 % relative humidity and 40 °C / 92 % relative humidity, 56 cycles			
Dry heat (60086-2-2)		100 °C, relative humidity <50 %, 7 days			
Moisture heat (60068-2-3)		40 °C, relative humidity 93 %, 56 days			
Site Altitude	[m]	to 2000 N.N.			
Protection Class		IP2X, when wired			
Resistance to Shock , Transport (60068-2-27)		30 g, 11 ms, all axes			30, 11 ms
Resistance to Vibration , Operation (60068-2-6)		5 g			
Rated Thermal Current I_{th}					
up to 40 °C ambient temperature	[A]	0.1...32	1.6...32	6.3...45	16... 90
up to 60 °C ambient temperature	[A]	0.1...32	1.6...32	6.3...45	16... 90
Rated Supply Current I_e	[A]	0.1...32	1.6...32	6.3...45	16... 90
Dependence on Temperature					
40 °C	[A]	no reduction			
50 °C	[A]	no reduction			
60 °C	[A]	no reduction			
70 °C	[A]	15 % current reduction of the upper rated current I_e			
Overload Protection					
Characteristics		IEC 60947-4-1 Motor protection (except Cat. Nos. 140M-C2N, 140M-D8N, 140M-F8N)			IEC 60947
Ambient Temperature Compensation	[°C]	-20 ...+60			
Phase-loss Protection		Differential release			
Trip class		10 (except Cat. Nos. 140M-C2N, 140M-D8N, 140M-F8N) fixed setting			10
Magnetic Release Release current (+/-20 %)		fixed setting 13...14 x I_e max. (for 140M-C2E, 140M-D8E, 140M-F8E, 140M-C2N, 140M-D8N, 140M-F8N) 16...21 x I_e max. (for 140M-C2T, 140M-D8T, 140M-F8T) I_e max. = maximum values of setting ranges			fixed setting 14 x I_e max.
Total Power loss P_v					
Circuit Breaker at rated load operating temperature	[W]	6...11.5	6...11.6	9...16	33
Main Disconnect Switch Application					
		Yes, with accessories			
		For utilization outside North America, assemblies (of products) shall comply to the IEC 61439-1 requirements			
Application Conditions		140M manual motor starters are intended for use in closed areas without hazardous operating conditions such as dust or explosive or corrosive gases. Enclosures of appropriate manner need to be in place to protect devices in such environments.			

Motor Protection Circuit Breakers and Motor Circuit Protectors Specifications

General Data, Continued

Cat. No.	140M-C...	140M-D...	140M-F...	140-CMN
Conformity to Standards	IEC 60947-1; -2; -4-1; EN 60947-1; -2; -4-1; UL 508; CSA 22.2, No. 14			IEC 60947-1; -2; EN 60947-1; -2; UL 508; CSA 22.2, No. 14
Approvals	CE, UL, CSA			CE, UL, CSA
Terminal Parts Type of terminals				
Screwdriver	Pozidriv No. 2/Blade No. 3		Pozidriv No. 2/Blade No. 3	
1. conductor [mm ²]/[AWG]	1...6/No. 16...10		2.5...25/No. 14...4	
2. conductor [mm ²]/[AWG]	1...4/No. 16...10		2.5...25/No. 14...4	
1. conductor [mm ²]/[AWG]	1...6/No. 16...10		2.5...25/No. 14...4	
2. conductor [mm ²]/[AWG]	1...6/No. 16...10		2.5...25/No. 14...4	
1. conductor [mm ²]/[AWG]	1.5...6/No. 16...8		16...25/No. 14...4	
2. conductor [mm ²]/[AWG]	1.5...6/No. 16...8		16...25/No. 14...4	
1. conductor [mm ²]/[AWG]	1...6/No. 16...10		2.5...10/No. 14...8	
2. conductor [mm ²]/[AWG]	1...6/No. 16...10		2.5...10/No. 14...8	
Tightening torque [Nm]/[lb•in]	2...2.5/18...22		3...3.5/27...30	

Screwless

Cat. No.	140M-RC...
Terminal Parts Type of terminals	
Screwdriver	
1. conductor [mm ²]/[AWG]	0.5...2.5/—
2. conductor [mm ²]/[AWG]	0.5...2.5/—
1. conductor [mm ²]/[AWG]	0.5...2.5/No. 18...12
2. conductor [mm ²]/[AWG]	0.5...2.5/No. 18...12
1. conductor [mm ²]/[AWG]	1...4/No. 16...12
2. conductor [mm ²]/[AWG]	1...4/No. 16...12

Accessories for Bulletin 140M Motor Protection Circuit Breakers





		Auxiliary Contact Blocks for Front Mounting Cat. No. 140M-C-AFA..., 140M-C-AFAR...			Auxiliary Contact Blocks for Right-Side Mounting Cat. No. 140M-C-ASA..., 140M-C-ASAR...				
Rated Thermal Current I_{th} at 40 °C ambient temperature [A]		5			10				
at 60 °C ambient temperature [A]		4			6				
Contact Class Coordination According to NEMA (UL/CSA Standards)	AC	B 300			B 600				
	DC	Q 300			Q 600				
Back-Up Fuses gG, gL	[A]	10			10				
Rated Supply Current	[V]	24	120	240	24	120	240	415	690
AC-15	[A]	4	3	1.5	6	5	3	2	0.7
DC-13	[V]	24	120	240	24	120	240	415	
	[A]	2	0.5	0.25	2	0.5	0.25	0.15	
Terminal Parts Type of terminals									
Screwdriver	Pozidriv No. 2/Blade No. 3								
1. conductor [mm ²]/[AWG]	0.5...1.5/18...14				0.5...2.5/18...14				
2. conductor [mm ²]/[AWG]	0.75...1.5/18...14				0.75...2.5/18...14				
1. conductor [mm ²]/[AWG]	0.75...1.5/18...14				0.75...2.5/18...14				
2. conductor [mm ²]/[AWG]	0.75...1.5/18...14				0.75...2.5/18...14				
1. conductor [mm ²]/[AWG]	0.75...1.5/18...14				0.75...2.5/18...14				
2. conductor [mm ²]/[AWG]	0.75...1.5/18...14				0.75...2.5/18...14				
Tightening torque [N•m]/[lb•in]	1.2...1.5/10.6...13				1.2...1.5/10.6...13				





Motor Protection Circuit Breakers and Motor Circuit Protectors

Specifications







Accessories for Bulletin 140M Motor Protection Circuit Breakers, Continued

		Undervoltage Trip for Left-Side Mounting Cat. No. 140M-C-UX...	Undervoltage Trip with 2 Auxiliary Contacts for Left-Side Mounting Cat. No. 140M-C-UC...	Shunt Trip for Left-Side Mounting Cat. No. 140M-C-SN...
Actuating Voltage				
Pull-in		0.85...1.1 x U _s	0.85...1.1 x U _s	0.7...1.1 x U _s
Drop-out		0.7...0.35 x U _s	0.7...0.35 x U _s	
Rated Control Voltage	min. max.	21V 50 Hz, 24V 60 Hz 600V 50 Hz	21V 50 Hz, 24V 60 Hz 600V 50 Hz	21V 50 Hz, 24V 60 Hz 600V 50 Hz
On-Time		100%	100%	100%
Coil Rating				
Pull-in		8.5 VA, 8 W	8.5 VA, 8 W	8.5 VA, 8 W
Hold		4 VA, 2 W	4 VA, 2 W	4 VA, 2 W
Terminal Parts				
Type of terminals		Pozidriv No. 2/Blade No. 3		
Screwdriver		Pozidriv No. 2/Blade No. 3		
	1. conductor [mm ²]/[AWG]	0.5...2.5/No. 18...14		
	2. conductor [mm ²]/[AWG]	0.75...2.5/No. 18...14		
	1. conductor [mm ²]/[AWG]	0.75...2.5/No. 18...14		
	2. conductor [mm ²]/[AWG]	0.75...2.5/No. 18...14		
Tightening torque		1.2...1.5/10.6...13.3		

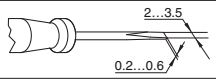
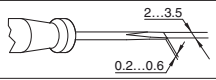

Rated Thermal Current I _{th} at 60 °C ambient temperature	Compact Busbar Feeder Terminal		Compact Busbar		Compact Busbar Feeder Block			
	140M-C-WTN 140M-C-WTEN	140M-F-WTE	140M-C -W...	140M-F -W...	140M-C-WBE L1, L2, L3	140M-C-WBE T1, T2, T3	140M-F-WBE L1, L2, L3	140M-F-WBE T1, T2, T3
[A]	64	120	64	120	64		IEC 120/UL 115	
 1. conductor [mm ²]/[AWG]	2.5...25/14...4	—	—	—	4...25/10...4	for use with 140M-C-W	4...50/10...4	for use with 140M-F-W
 1. conductor [mm ²]/[AWG]	2.5...25/14...4	4...50/12...1/0	—	—	4...25/10...4	for use with 140M-C-W	4...25/10...4	for use with 140M-F-W
 1. conductor [mm ²]/[AWG]	2.5...25/14...4	2.5...50/12...1/0	—	—	2.5...25/14...4	for use with 140M-C-W	2.5...25/14...4	for use with 140M-F-W
Tightening torque	[N•m]/[lb•in]	3...3.5/27...31	5...6/45...54	—	—	3...3.5/27...31	2.5...3/23...27	5...6/45...54

Accessories for Bulletin 140M Screwless

Cat. No.		140M-RC...	
Terminal Parts			
Type of terminals			
Screwdriver			
	1. conductor [mm ²]/[AWG]	0.5...1.5/—	
	2. conductor [mm ²]/[AWG]	0.5...1.5/—	
	1. conductor [mm ²]/[AWG]	0.5...1.5/No. 18...14	
	2. conductor [mm ²]/[AWG]	0.5...1.5/No. 18...14	
	1. conductor [mm ²]/[AWG]	0.5...1.5/No. 18...14	
	2. conductor [mm ²]/[AWG]	0.5...1.5/No. 18...14	

Motor Protection Circuit Breakers and Motor Circuit Protectors

Specifications

Weights

Description	Weight [g]	Cat.No.	
Motor Protection Circuit Breakers	317	140M-C2E-...	
	373	140M-D8E-...	
	782	140M-F8E-...	
	315	140M-C2N-...	
	365	140M-D8N-...	
	782	140M-F8N-...	
	315	140M-C2T-...	
	365	140M-D8T-...	
	782	140M-F8T-...	
	1845	140-CMN-...	
Auxiliary Contacts	10	140M-C-AFA10	
		140M-C-AFA01	
		140M-C-AFA11	
		140M-C-AFA20	
		140M-C-ASA...	
	15	140M-C-AFAR10A...	
		140M-C-ASAR...M...	
Undervoltage Trip	31	140M-C-ASAM11	
		140-CA...	
		108	140M-C-UX...
		110	140M-C-SN...
Trip Contact Blocks	94	140M-C-UC...	
		140-CUV...	
Shunt Trip	94	140-CT...	
		140-CRT...	

Description	Weight [g]	Cat.No.	
Anti-Tamper Cover	2	140M-C-CA	
Lockable Twist Knob	5	140M-C-KN1	
		140M-C-KRY1	
Locking Tag	30	140M-C-M3	
Door Coupling Handle	123	140M-C-DN66	
		140M-C-NRY66	
Extension Shaft	46	140M-C-DS	
Legend Plate	4	140M-C-DFC...	
Feeder Terminal	51	140M-C-WTEN	
		140M-F-WT	
Compact Busbars	172	140M-C-W452N	
		27	140M-C-W453N
		48	140M-C-W454N
		69	140M-C-W455N
		90	140M-C-W542N
		30	140M-C-W543N
		55	140M-C-W544N
Top Hat Rail Adapter	80	140M-C-W545N	
		105	140-CRBH2
	6	140-KBH2	

Motor Protection Circuit Breakers and Motor Circuit Protectors

Specifications

Accessories for Bulletin 140-CMN Circuit Breakers

	Cat. No. 140-CT Trip Contact Block for Flush Mounting on Cat. No. 140-CMN Circuit Breakers						Cat. No. 140-CRT, 140-CUV Undervoltage Trip and Shunt Trip for Flush Mounting on Cat. No. 140-CMN Circuit Breakers					
Rated Thermal Current I_{th} up to 40 °C ambient temperature up to 60 °C ambient temperature	[A] [A]	10 6						2 2				
NEMA contact class (UL/CSA-Approval)	AC DC	B 600 Standard Pilot Duty R 300 Light Pilot Duty						Make/Break max. voltage 432 VA72 VA480 V 28 VA28 VA250 V				
Back-Up Fuse gG, gL		16 A						16 A				
Rated Current I_e												
AC-15:	[V] [A]	230 3	400 2.5	500 1.5	690 0.75		AC-14:	24 1.5	110 1.5	230 1.0	400 1.0	500 0.75
DC-13:	[V] [A]	24 2	48 0.6	110 0.2	230 0.1	440 0.04	DC 13:	24 1.5	48 0.5	60 0.4	110 0.2	
Terminals												
Screwdriver												
1.conduct or 2.conduct or	[mm2]/[AWG] [mm2]/[AWG]	0.75... 2.5/No. 18... 14 0.75... 2.5/No. 18... 14						0.75... 2.5/No. 18... 14 0.75... 2.5/No. 18... 14				
1.conduct or 2.conduct or	[mm2]/[AWG] [mm2]/[AWG]	0.75... 2.5/No. 18... 14 0.75... 2.5/No. 18... 14						0.75... 2.5/No. 18... 14 0.75... 2.5/No. 18... 14				
Tightening torque	[N•m]/[lb•in]	1... 1.5/8.8... 10.3						1... 1.5/8.8... 10.3				



		Cat. No. 140-CUV... Undervoltage Trip Unit for Right-Side Mounting on Cat. No. 140-CMN Circuit Breakers	Cat. No. 140-CRT... Shunt Trip for Flush Mounting on Cat. No. 140-CMN Circuit Breakers
Operating Voltage			
Pick-up		0.8... 1.1 x U_s	0.7... 1.1 x U_s
Drop-out		0.7... 0.35 x U_s	—
Duty cycle		100 % ED	100 % ED
Control Voltage			
	min.	12 V 50 Hz/14 V 60 Hz	12 V 50 Hz/14 V 60 Hz
	max.	600 V 50 Hz	600 V 50 Hz
Coil Performance			
Pick-up	[VA/W]	11 / 8	12 / 7
Drop-out	[VA/W]	4 / 1	6 / 2
Terminals			
Terminal type			
Fine-stranded	[mm2]	2 x 0.75...2.5	2 x 0.75...2.5
Coarse-stranded	[mm2]	2 x 0.75...2.5	2 x 0.75...2.5
Tightening torque	[Nm]	1... 1.5	1... 1.5
Coarse-stranded	[AWG]	No. 18.... 14	No. 18.... 12
Tightening torque	[lb•in]	8.8... 10.3	8.8... 10.3

Motor Protection Circuit Breakers and Motor Circuit Protectors

Specifications

Cut-off current

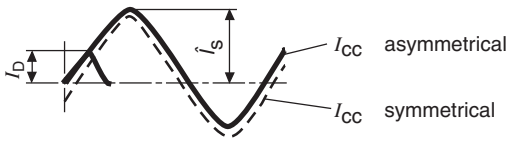

The Bulletin 140-M limits solid short-circuit current I_{CC} (prospective short-circuit current). I_D is the maximum cut-off current (highest instantaneous value of the limited short-circuit current). This value is indicated in the following diagrams as a function of the progressive system short-circuit current.

2

Bulletin 140M-C Circuit Breaker (Maximum Cut-Off Current)

140M-C2E, -C2N, -C2T
 Max. Cut-Off Current, $U_e = 400...415V$

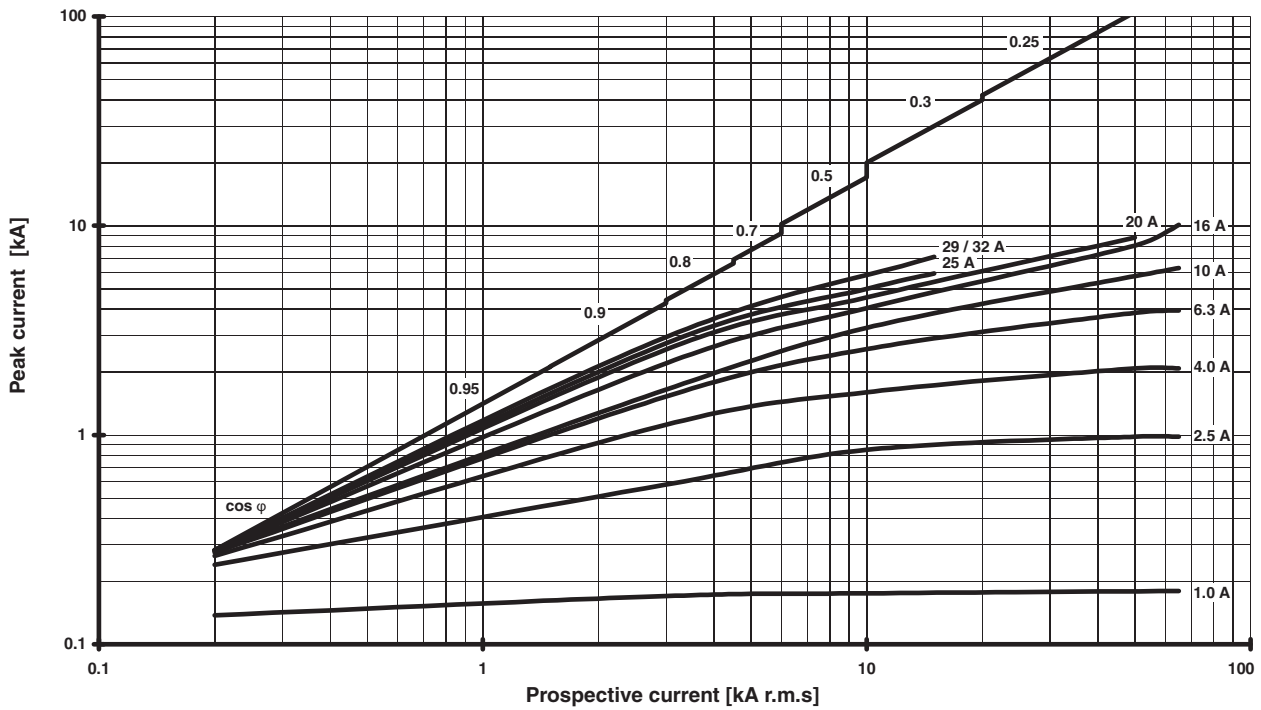

Bulletin 140M-D Circuit Breaker (Maximum Cut-Off Current)

140M-D8E, -D8N, -D8T
 Max. Cut-Off Current, $U_e = 400...415V$

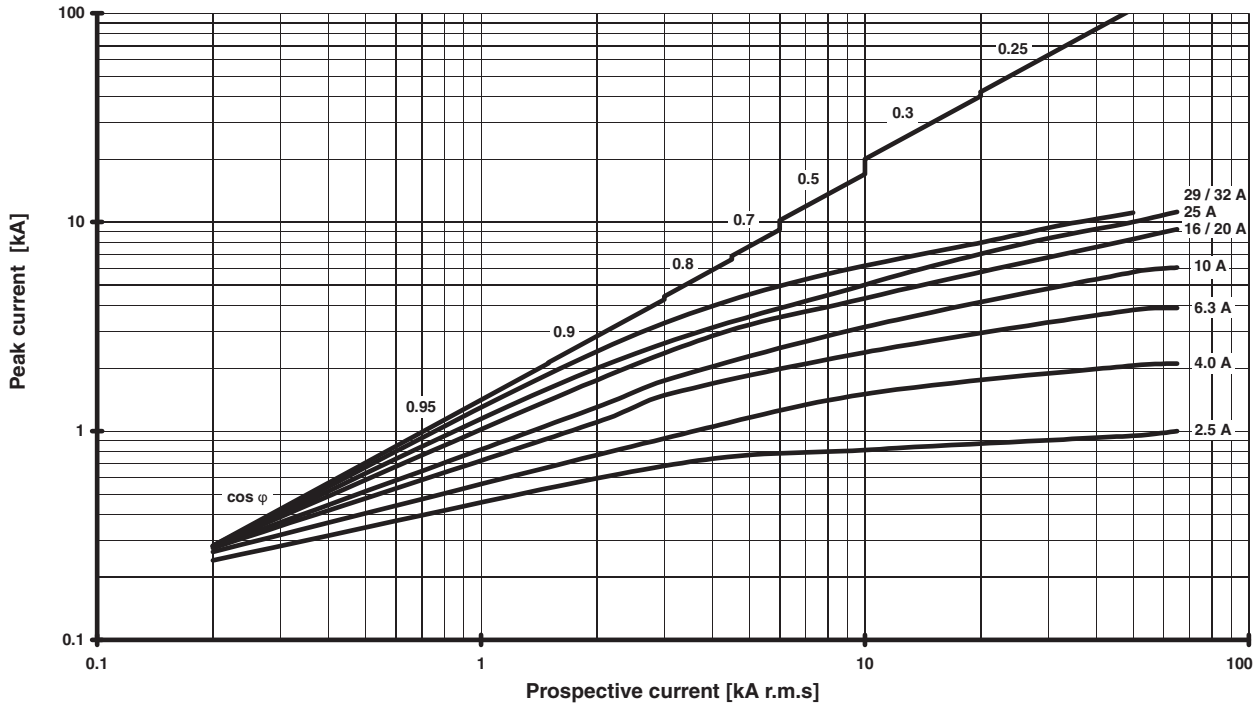

2

Bulletin 140M-F Circuit Breaker (Maximum Cut-Off Current)

140M-F8E, -F8N, -F8T
 Max. Cut-Off Current, $U_e = 400...415V$

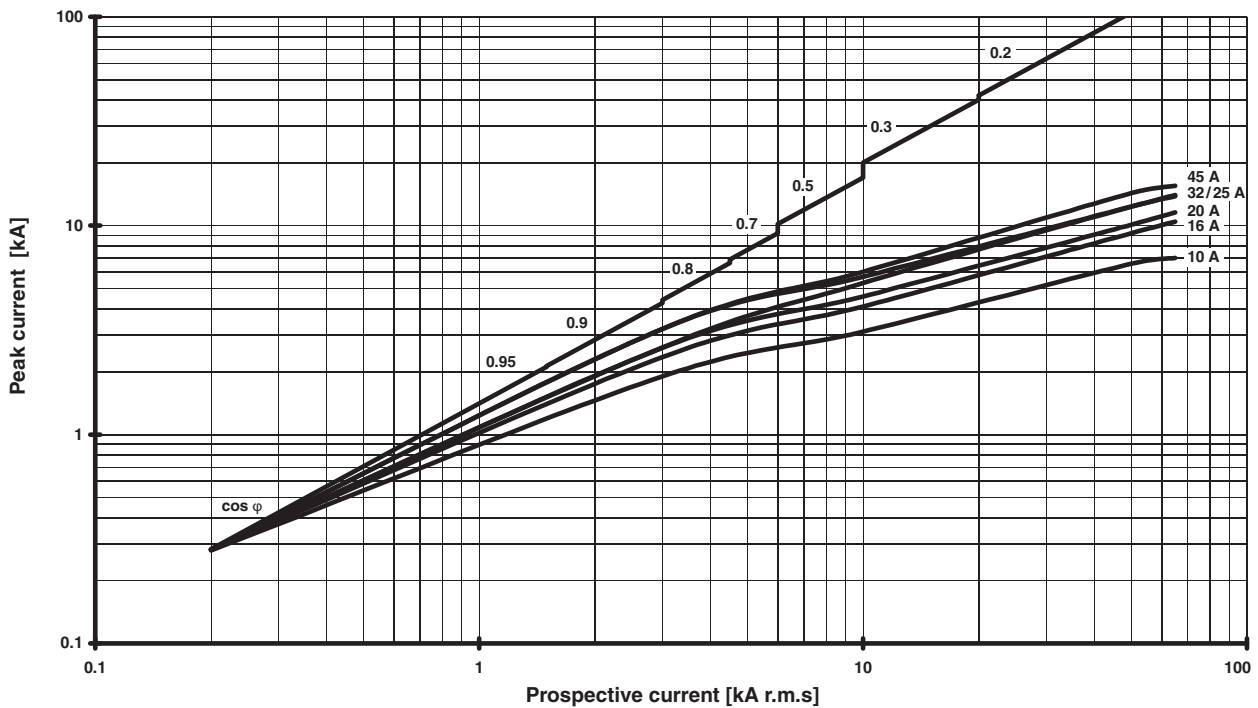

Bulletin 140M-C Circuit Breaker (Maximum Let-Through-Energy)

140M-C2E, -C2N, -C2T
Max. Let-Through-Energy, $U_e = 400...415V$

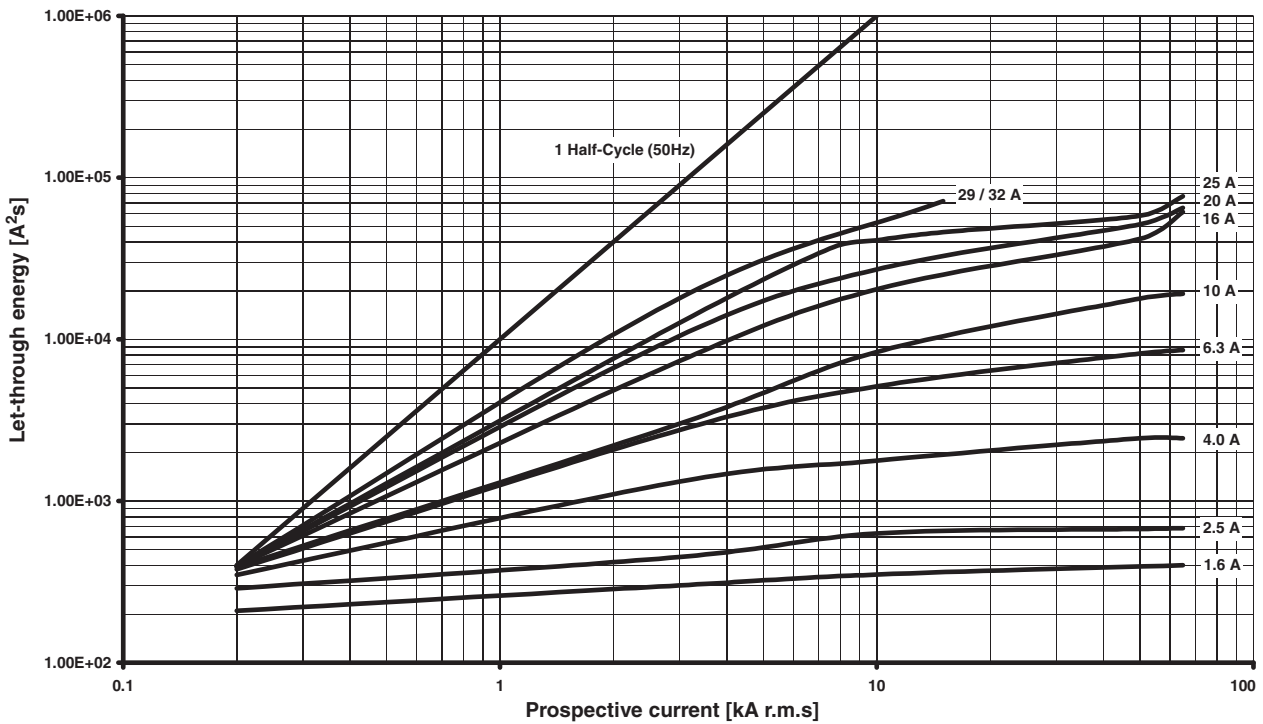

Bulletin 140M-D Circuit Breaker (Maximum Let-Through-Energy)

140M-D8E, -D8N, -D8T
Max. Let-Through-Energy, $U_e = 400...415V$

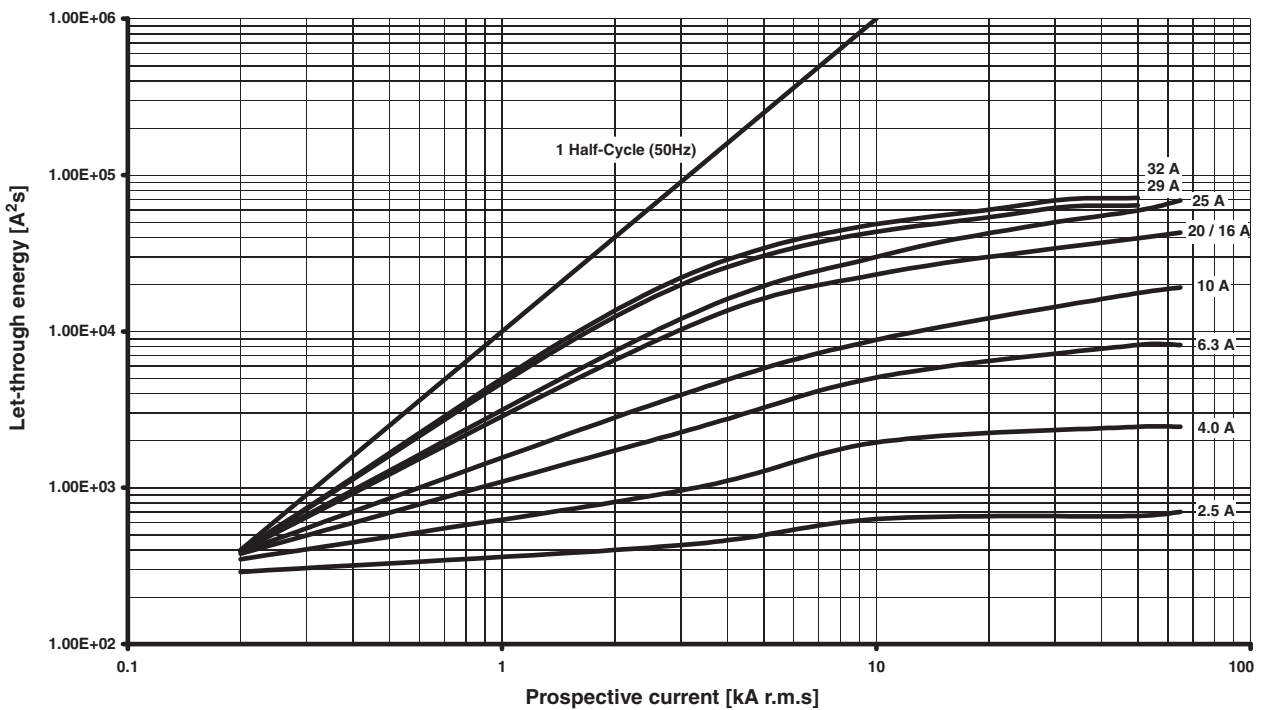

Bulletin 140M-F Circuit Breaker (Maximum Let-Through-Energy)

140M-F8E, -F8N, -F8T
Max. Let-Through-Energy, $U_e = 400...415V$

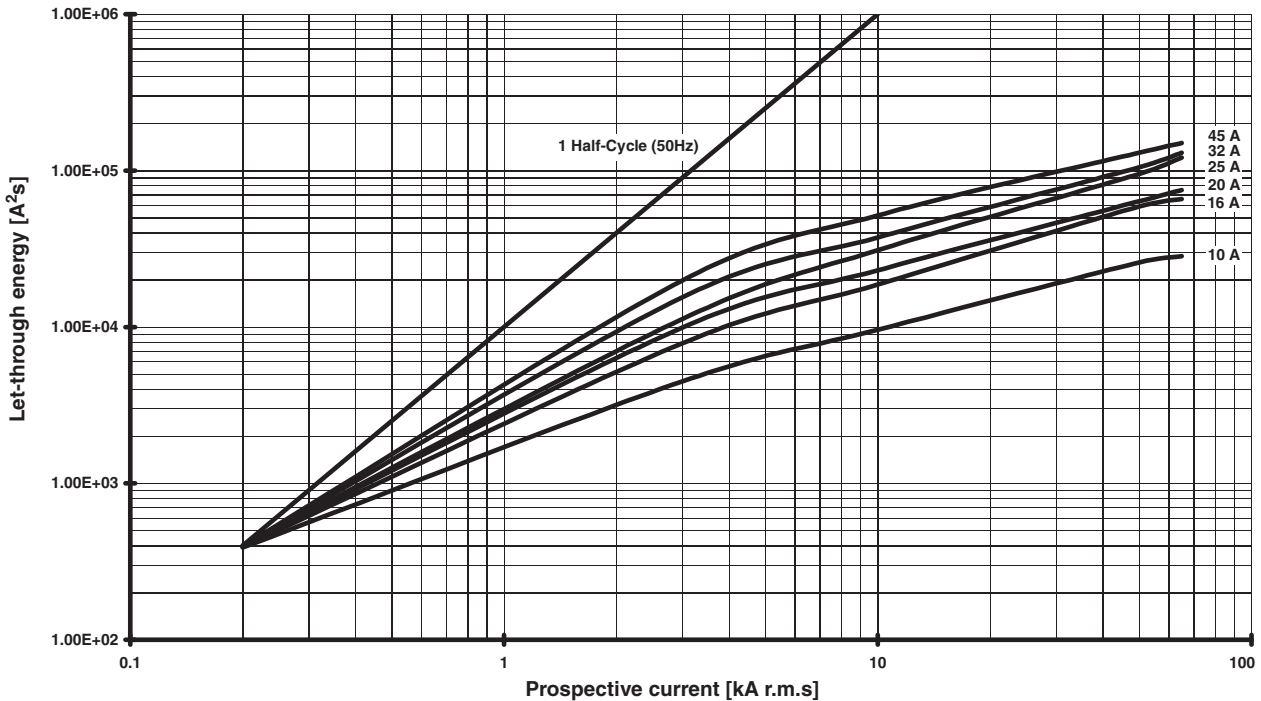

Time-Current Characteristic

Bulletin 140M-C, -D, -F Motor Protection Circuit Breakers

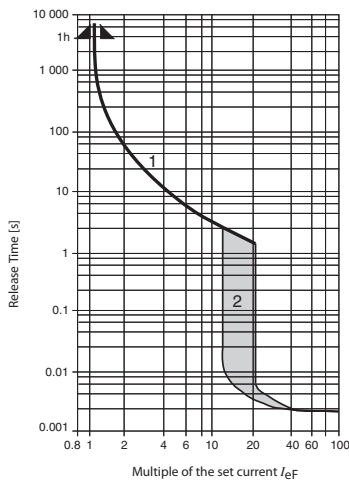

Bulletin 140-CMN Motor Protector

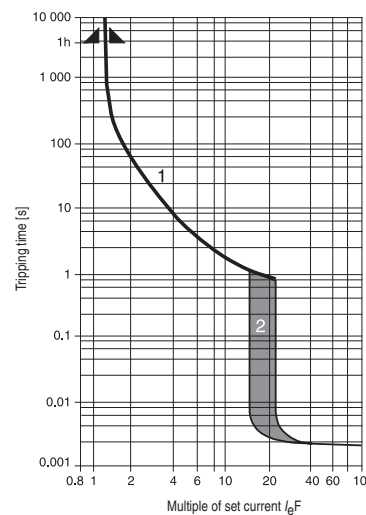

1) Thermal Release Trip Current

The adjustable current-dependent delayed bimetal release protects motors against overload. The curve shows the mean operating current at an ambient temperature of 20 °C starting from the cold state. Careful testing and setting ensures effective motor protection even in the case of single-phasing. The overload characteristic is also valid for transformer protection.

2) Magnetic Release Trip Current

The instantaneous magnetic trip has a fixed operating current setting. This corresponds to 13...14 times the maximum value of setting range. (Transformer protection up to 20 x I_e max.) At a lower setting it is correspondingly higher.

Current Setting I_{eF}

The overload trip corresponds to a thermal overload relay in a motor starter conforming to IEC947-4-1. If a different value is prescribed (e.g., reduced I_e for cooling medium having a temperature higher than 40 °C or a place of installation higher than 2000 m above sea level), the setting current is equal to the reduced rated current I_e of the motor.

Motor Protection Circuit Breakers and Motor Circuit Protectors

Approximate Dimensions

Cat. No. 140M-C, -D, -F

Dimensions are shown in millimeters (inches). Dimensions are not intended to be used for manufacturing purposes.

Cat. No. 140M-C2...

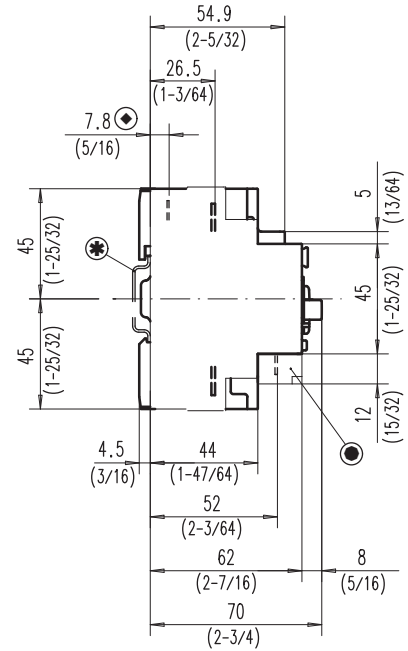
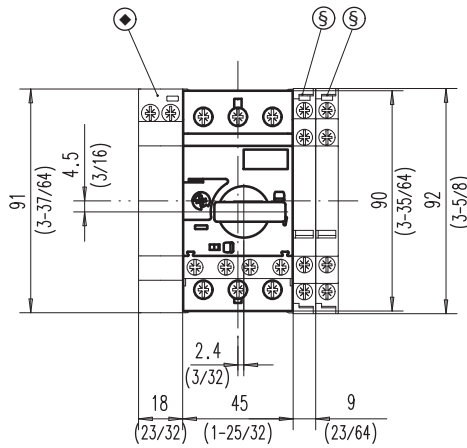
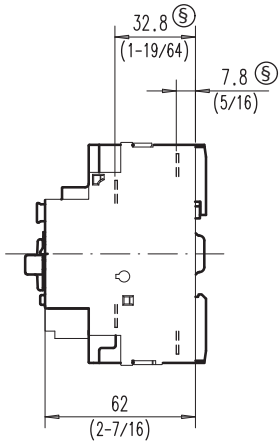

Cat. No. 140M-D8...

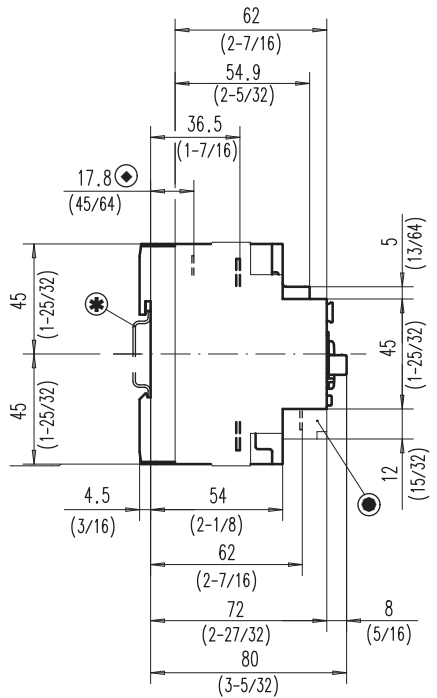
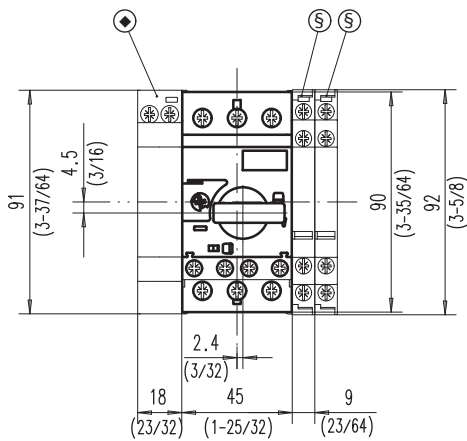
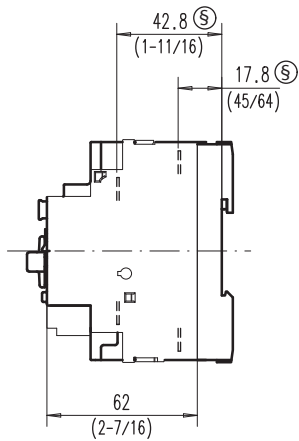

- * Mounting on 35 mm DIN Rail
- ◆ Undervoltage/shunt trip
- Auxiliary contact (front mounted)
- § Auxiliary contact (side mounted)

Motor Protection Circuit Breakers and Motor Circuit Protectors

Approximate Dimensions

Dimensions are shown in millimeters (inches). Dimensions are not intended to be used for manufacturing purposes.

Cat. No. 140M-F8...

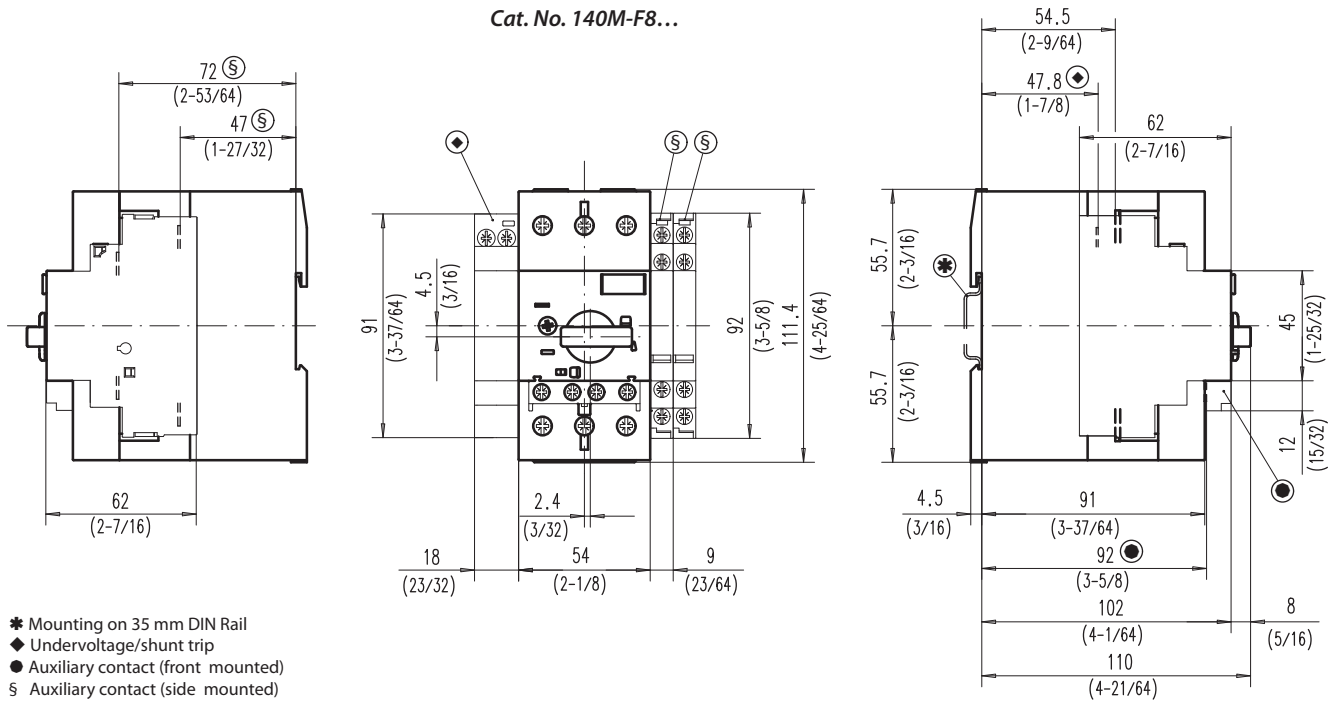

Cat. No. 140M-RC, Screwless

Cat. No. 140M-RC...

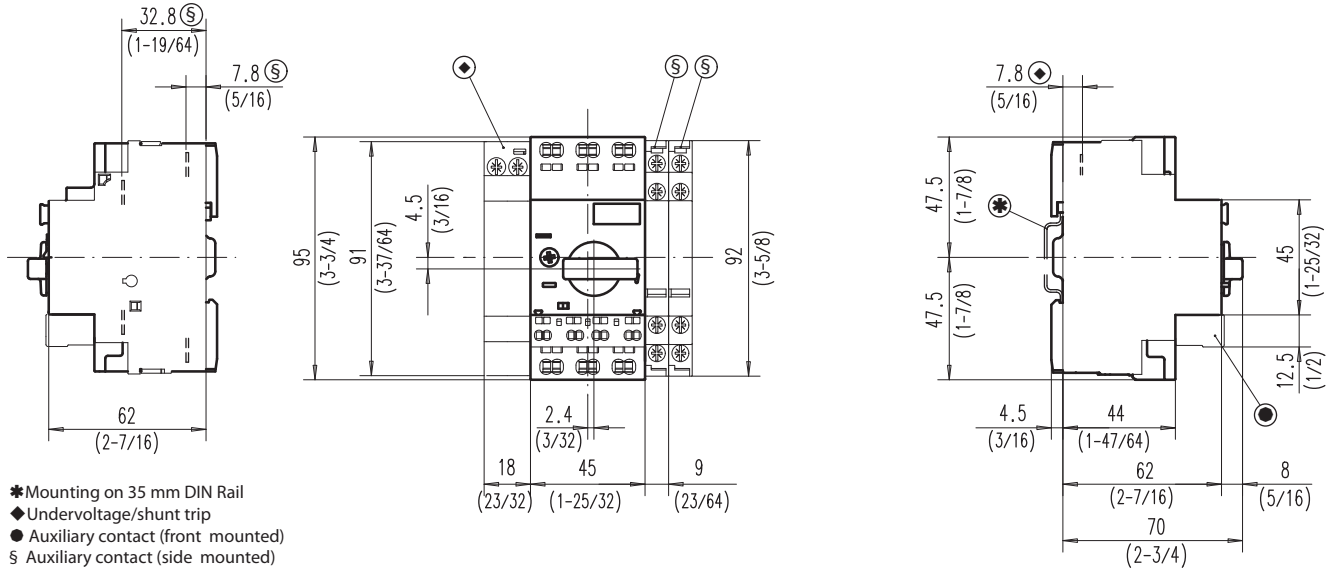

Motor Protection Circuit Breakers and Motor Circuit Protectors

Approximate Dimensions

Dimensions are shown in millimeters (inches). Dimensions are not intended to be used for manufacturing purposes.

Cat. No. 140M-C/D...

Cat. No. 140M-F...

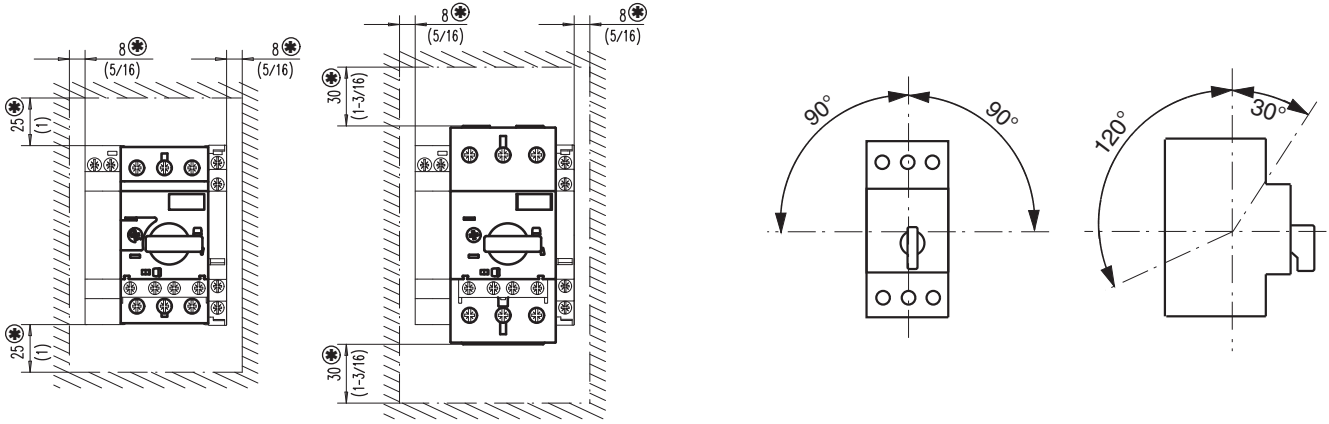

* Minimum distance to grounded parts or walls

Mounting position/safety clearance of Cat. No. 140M-C..., 140M-D..., 140M-F...

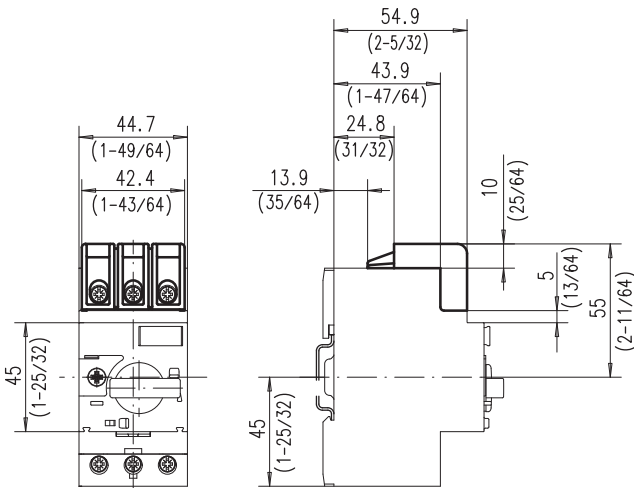

Cat. No. 140M-C-TE1 Type E adapter on Cat. No. 140M-C2E...

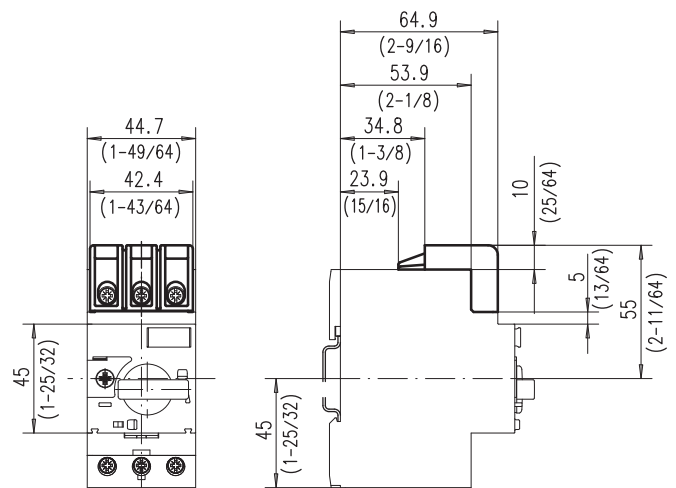

Cat. No. 140M-C-TE1 Type E adapter on Cat. No. 140M-D8E...

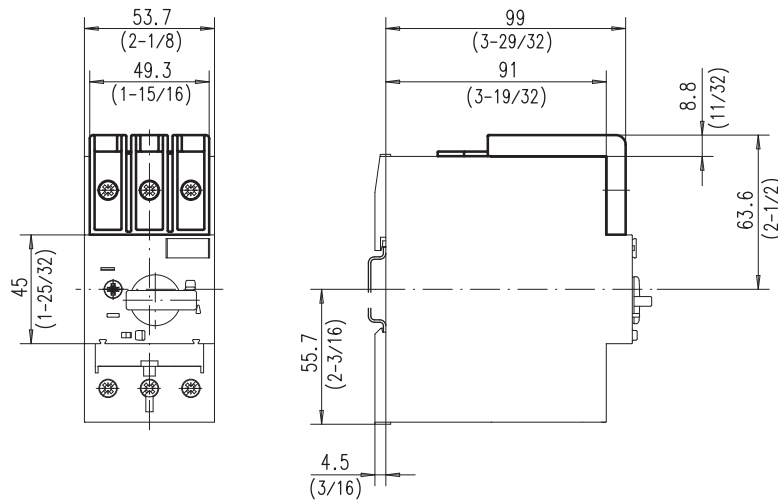

Cat. No. 140M-C-TE1 Type E adapter on Cat. No. 140M-F8E...



Motor Protection Circuit Breakers and Motor Circuit Protectors

Approximate Dimensions

Dimensions are shown in millimeters (inches). Dimensions are not intended to be used for manufacturing purposes.

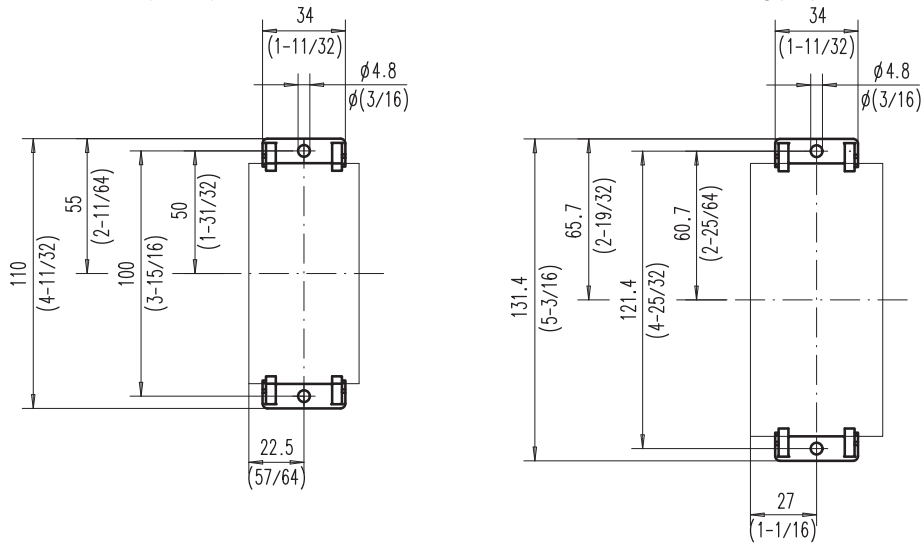

Screw Adapter 140M-C-N45 for 140M-C2/D8 and 140M-F8

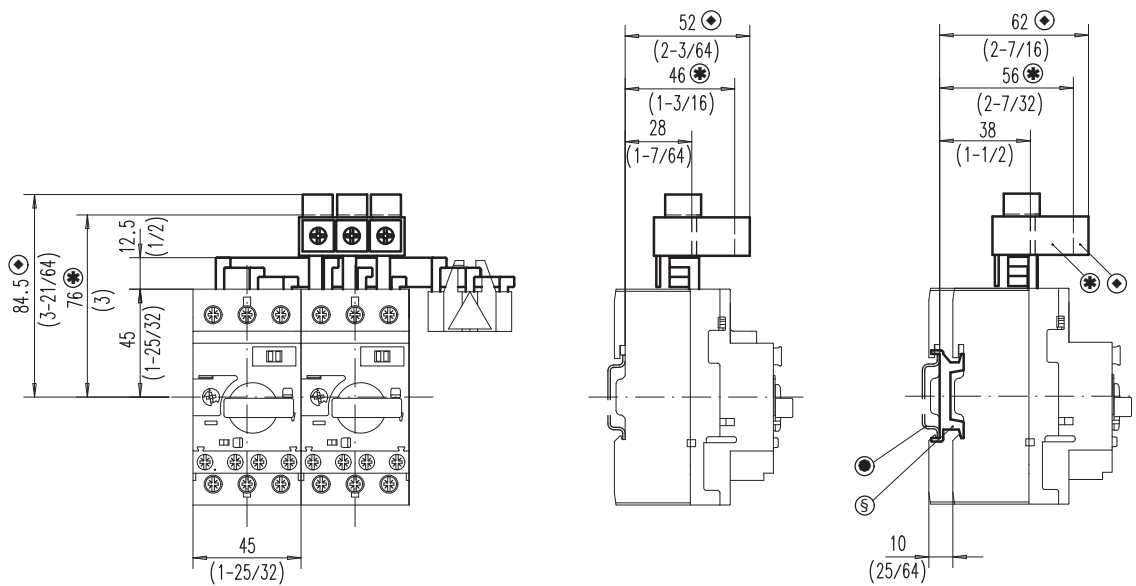

- ◆ Compact Busbar Feeder Terminal IEC
- ◆ Compact Busbar Feeder Terminal UL type E and IEC
- Mounting on 35 mm DIN Rail
- § Top Hat Rail Adapter 10 mm

Cat. No. 140M-C with Busbar

Motor Protection Circuit Breakers and Motor Circuit Protectors

Approximate Dimensions

Dimensions are shown in millimeters (inches). Dimensions are not intended to be used for manufacturing purposes.

2

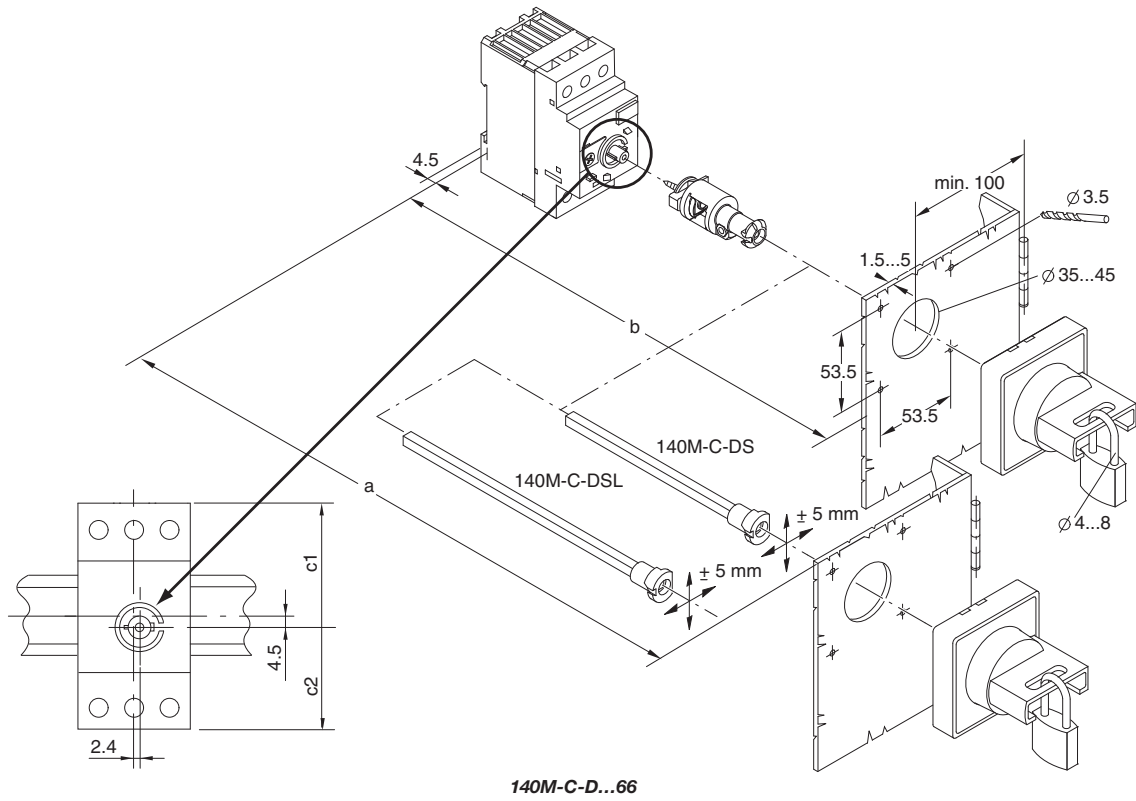

With Cat. No. 140-M-C-DS Shaft

Cat. No.	a	b	c1	c2
140M-C	117...338	105.5 ±5	49.5	40.5
140M-D	126...347	114.5 ±5	49.5	40.5
140M-F	148.6...369.6	137.1 ±5	59.35	50.35

With Cat. No. 140-M-C-DSL Shaft

Cat. No.	a	b	c1	c2
140M-C	117...438	105.5 ±5	49.5	40.5
140M-D	126...497	114.5 ±5	49.5	40.5
140M-F	148.6...519	137.1 ±5	59.35	50.35

Motor Protection Circuit Breakers and Motor Circuit Protectors

Approximate Dimensions

Dimensions are shown in millimeters (inches). Dimensions are not intended to be used for manufacturing purposes.

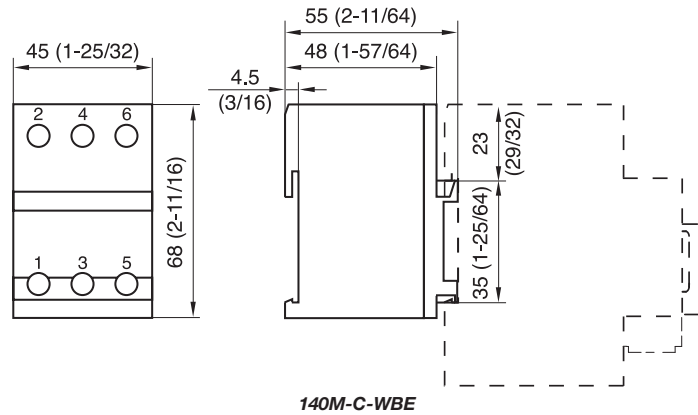

2

Cat. No. 198E...

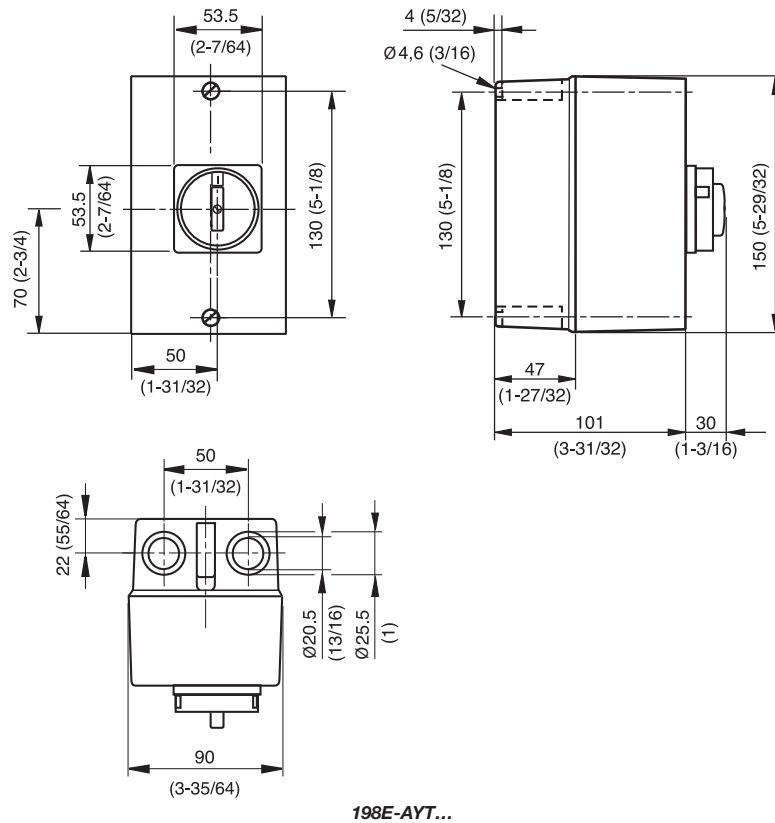

Motor Protection Circuit Breakers and Motor Circuit Protectors

Approximate Dimensions

Dimensions are shown in millimeters (inches). Dimensions are not intended to be used for manufacturing purposes.

Cat. No. 140-CMN...

2

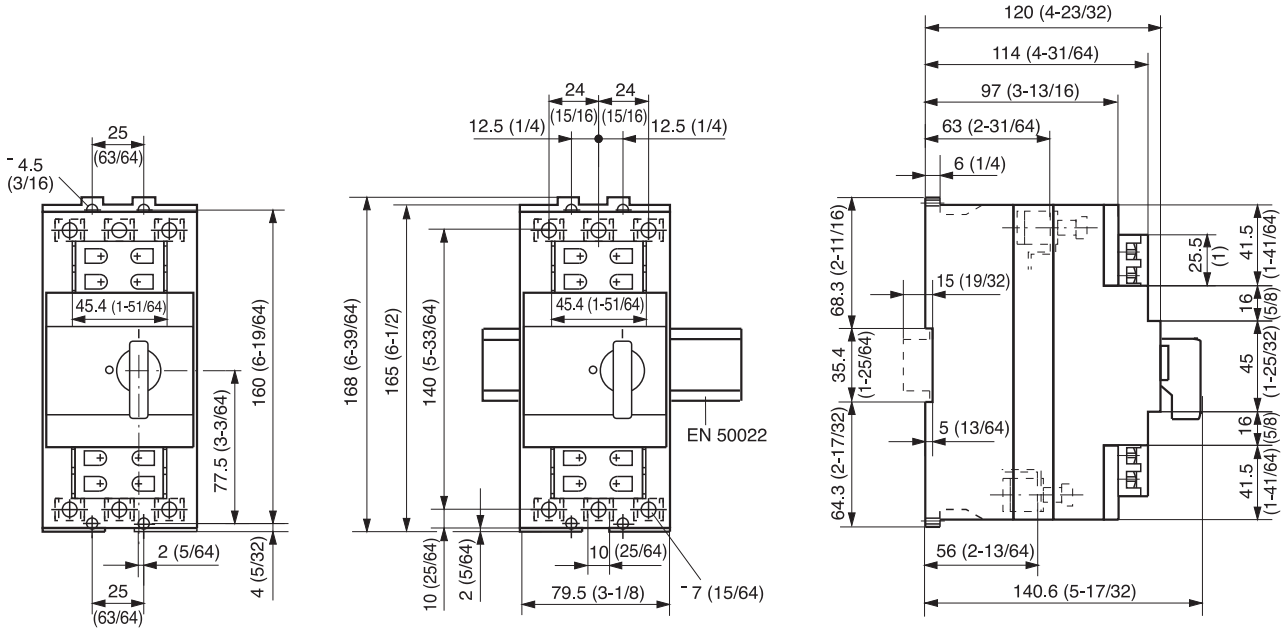

140-CMN

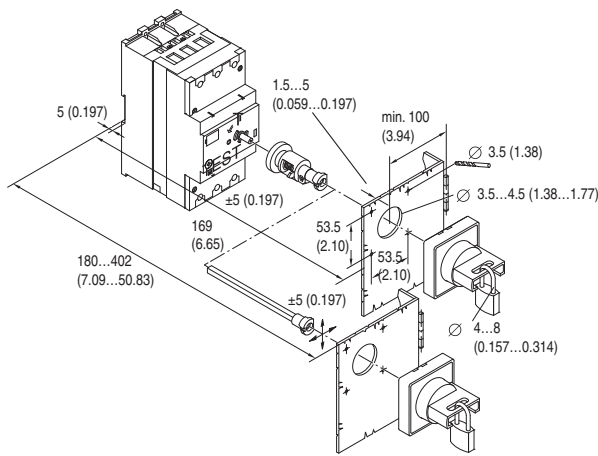

140-CD...

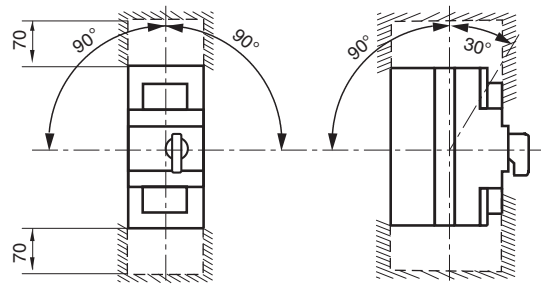

Mounting position/safety clearance of Cat. No. 140-CMN

Note: See Bulletin 140U-H, J, L and N for dimensions of 140M-H, J, L and N frames.

Motor Protection Circuit Breakers and Motor Circuit Protectors

Approximate Dimensions

Dimensions are shown in millimeters (inches). Dimensions are not intended to be used for manufacturing purposes.

Cat. Nos. 140M-H, -I, -J, -L, -N

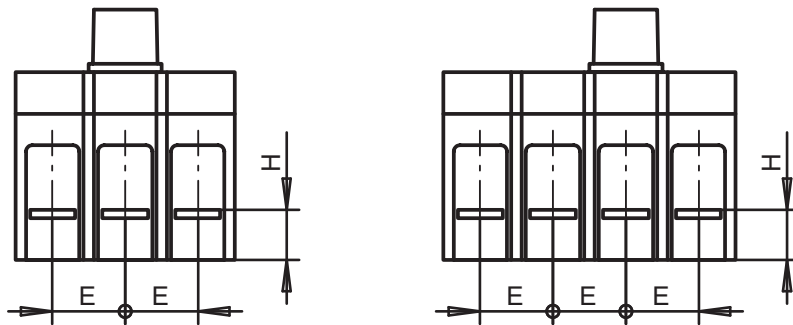
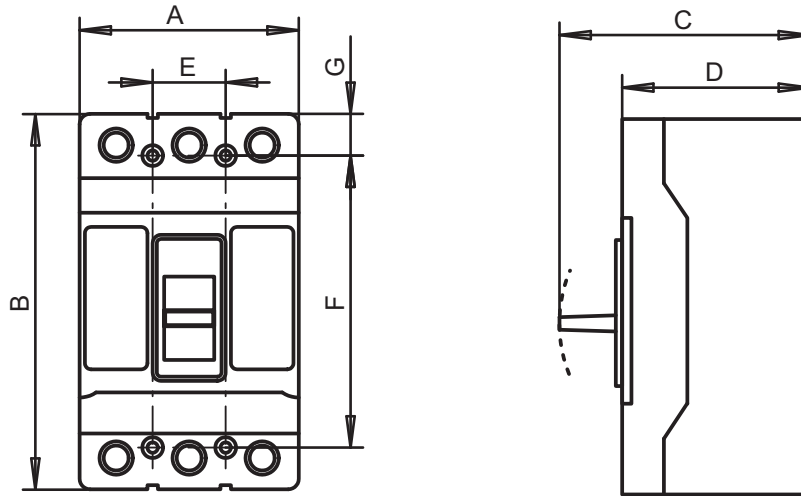

	A	B	C	D	E	F	G	H
H-Frame	77 (3)	140 (5-1/2)	88 (3-1/2)	75 (3)	25.4 (1)	96.8 (3-13/16)	24.6 (31/32)	22.4 (7/8)
I-Frame	105 (4-1/8)	152 (6)	105 (4-1/8)	88 (3-1/2)	35 (1-3/8)	114 (4-1/2)	19 (3/4)	40 (1-9/10)
J-Frame	105 (4-1/8)	178 (7)	113 (4-29/64)	88 (3-1/2)	35 (1-3/8)	139.7 (5-1/2)	19.8 (25/32)	20.6 (13/16)
L-Frame	140 (5-1/2)	258 (10-5/32)	138 (5-7/16)	110 (4-21/64)	43.7 (1-23/32)	214.4 (8-7/16)	21.3 (27/32)	24.7 (31/32)
N-Frame	210 (8-17/64)	407 (16-1/64)	183 (7-13/64)	140 (5-1/2)	69.9 (2-3/4)	374.7 (14-3/4)	16 (5/8)	29.5 (1-5/32)

2