

# XCK-MR54D1 / XCK-MR54D2 / XCK-MR54D1H29 / XCK-MR54D2H29

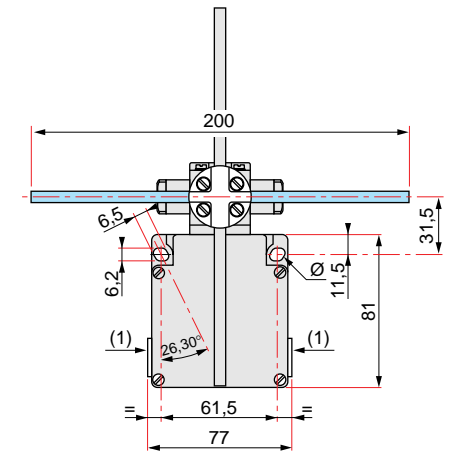

- (1) XCK-MR54D● = 3 x PE13 (DIN Pg 13,5)    XCK-MR54D●H29 = 3 x M20 x 1.5
- (2) 4 trous pour pied de centrage Ø 4 H11, entraxe 64,6 ± 0,2 x 56,4 ± 0,2
- (2) 4 locating pin holes Ø 4 H11, centres 64,6 ± 0,2 x 56,4 ± 0,2
- (Ø) 2 trous oblongs 6,2 x 6,5, parallélogramme incliné à 26°30 par rapport à l'axe longitudinal, pour vis M5
- (Ø) 2 rectangular holes 6,2 x 6,5, parallelogram inclined at 26°30 in respect to the longitudinal axis for M5 screws

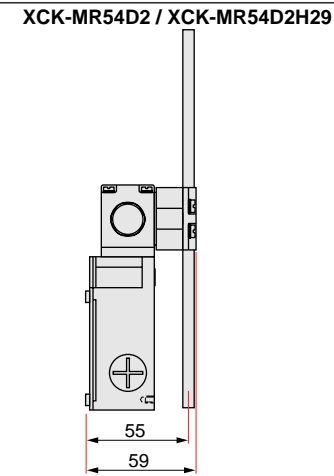
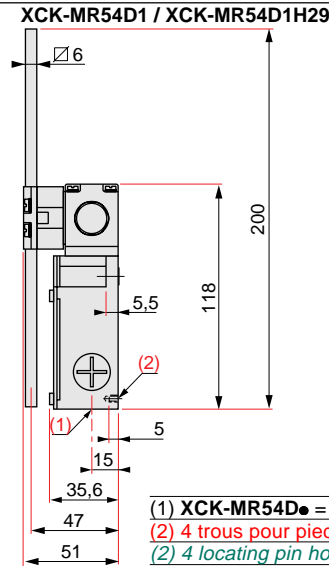
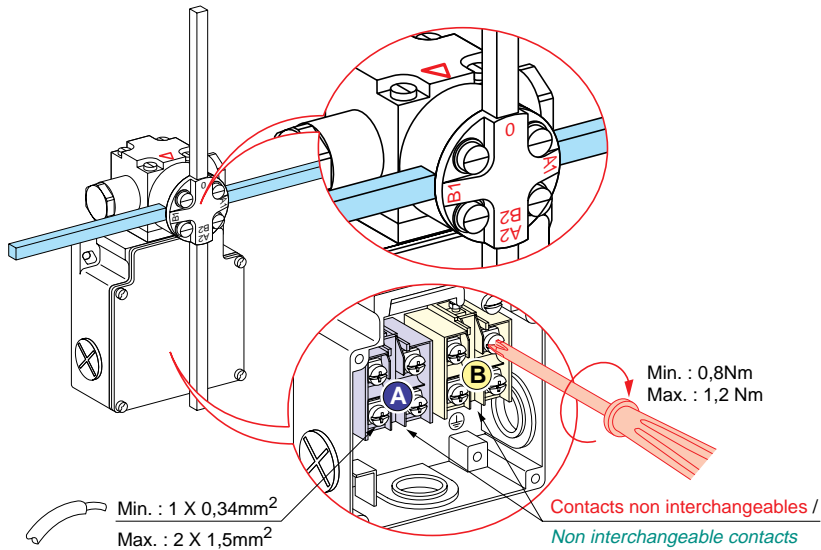
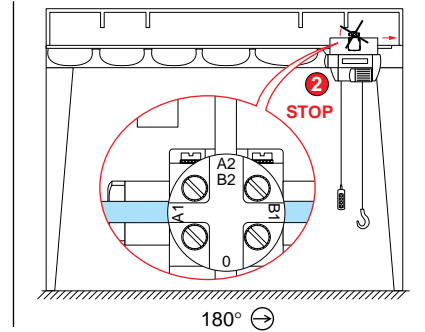
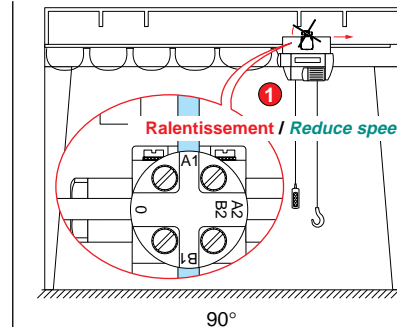
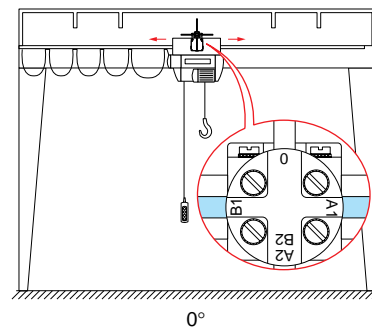
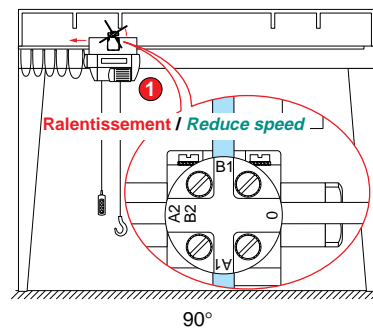
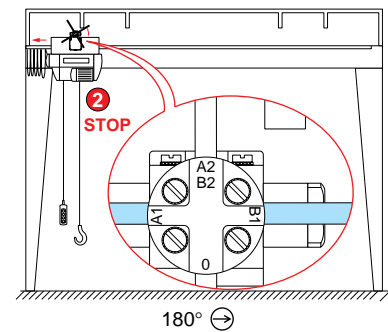

contact A					11-12
contact B					21-22
					11-12
					21-22

