

PEP information for auxiliaries and accessories

Suppressor modules

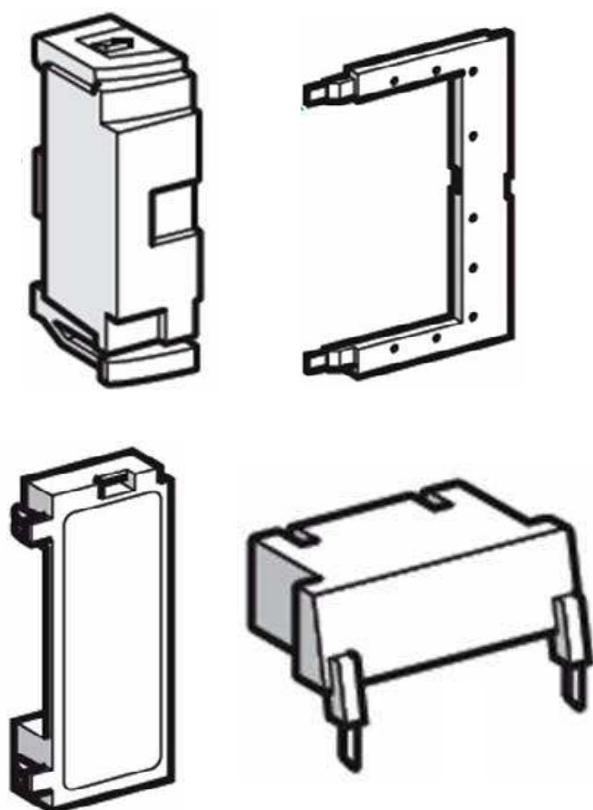

Environmental impacts for auxiliaries and accessories

Schneider-Electric publishes the product environmental impacts of the main function of the offer in the PEP document. It is the Product Environmental Profile of this main function product. The “PEP information for auxiliaries and accessories” document completes the product environmental information included in the PEP with impact information for auxiliaries and accessories.

These auxiliaries and accessories environmental impacts are presented as average percentages of the impact of the main function disclosed in the PEP.

Main function product overview

This “PEP information for auxiliaries and accessories” document completes the impact information for TeSys D contactors which is the main function of the range.

Environmental impacts are included in the PEP “TeSys D contactors 25 to 38 A AC version”. Reference is ENVPEP110229EN_V0.

Auxiliaries and accessories overview

There are different types of suppressor block accessories:

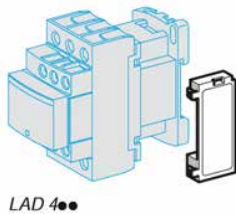

LAD 4●●

- RC circuits (Resistor-Capacitor)

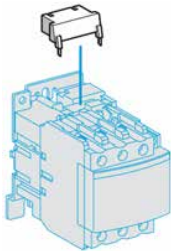

LA4 D●●

- Flywheel diodes

- Varistors (peak limiting)

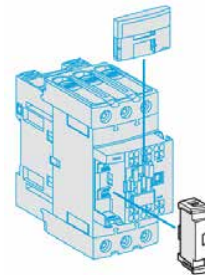

LAD 4RC3●, LAD 4V3●,
LAD 4D3U, LAD 4T3●

- Bidirectional peak limiting diodes

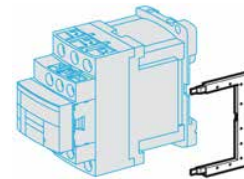

LAD 4DDL or LAD 4T●DL

The representative products used for the LCA are LA4DA2U and LA4DC3U.

The environmental analysis was performed in conformity with ISO 14040.

Environmental impacts

The impacts of auxiliaries of TeSys D range are in the table hereunder.

The auxiliaries and accessories types are grouped in categories with the same average percentage. The impact indicators percentages are common for :

- the RMD indicator (Raw Material Depletion) ,
- the 10 other indicators of the PEP.

To evaluate the impacts of one auxiliary or accessory, you should apply these percentages to the impact of the main function which is disclosed in the PEP.

These impacts have to be added to the impacts of the main function depending on the number of auxiliaries and accessories used.

Main Function Product:	TeSys D contactors
Category of auxiliary or accessory	Suppressor Block
RMD and other indicators	5%

Life cycle assessment studies has been performed with the EIME software (Environmental Impact and Management Explorer), version 4.1, and with its database version 11.0.

Schneider Electric Industries SAS

35, rue Joseph Monier
CS 30323
F- 92506 Rueil Malmaison Cedex
RCS Nanterre 954 503 439
Capital social 896 313 776 €

www.schneider-electric.com