

## SR2B201BD

compact smart relay Zelio Logic - 20 I O - 24 V DC - clock - display

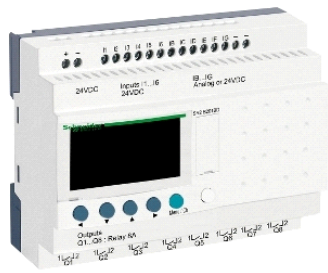

### Main

Range of product	Zelio Logic
Product or component type	Compact smart relay

### Complementary

Local display	With
Number of control scheme lines	0...500 with FBD programming 0...240 with ladder programming
Cycle time	6...90 ms
Backup time	10 years at 25 °C
Clock drift	6 s/month at 25 °C 12 min/year at 0...55 °C
Checks	Program memory on each power up
[Us] rated supply voltage	24 V DC
Supply voltage limits	19.2...30 V
Supply current	100 mA (without extension)
Power dissipation in W	6 W without extension
Reverse polarity protection	With
Discrete input number	12 conforming to EN/IEC 61131-2 type 1
Discrete input type	Resistive
Discrete input voltage	24 V DC
Discrete input current	4 mA
Counting frequency	1 kHz for discrete input
Voltage state 1 guaranteed	$\geq 15$ V for I1...IA and IH...IR discrete input circuit $\geq 15$ V for IB...IG used as discrete input circuit
Voltage state 0 guaranteed	$\leq 5$ V for I1...IA and IH...IR discrete input circuit $\leq 5$ V for IB...IG used as discrete input circuit
Current state 1 guaranteed	$\geq 1.2$ mA for IB...IG used as discrete input circuit $\geq 2.2$ mA for I1...IA and IH...IR discrete input circuit
Current state 0 guaranteed	$\leq 0.75$ mA for I1...IA and IH...IR discrete input circuit $\leq 0.75$ mA for IB...IG used as discrete input circuit
Input compatibility	3-wire proximity sensors PNP (discrete input)
Analogue input number	6
Analogue input type	Common mode
Analogue input range	0...10 V 0...24 V
Maximum permissible voltage	30 V (analogue input circuit)
Analogue input resolution	8 bits
LSB value	39 mV (analogue input circuit)
Conversion time	Smart relay cycle time for analogue input circuit
Conversion error	+/- 5 % at 25 °C for analogue input circuit +/- 6.2 % at 55 °C for analogue input circuit
Repeat accuracy	+/- 2 % at 55 °C for analogue input circuit
Operating distance	10 m between stations, with screened cable (sensor not isolated) for analogue input

The information provided in this documentation contains general descriptions and/or technical characteristics of the performance of the products contained herein. This documentation is not intended as a substitute for and is not to be used for determining suitability or reliability of these products for specific user applications. It is the duty of any such user or integrator to perform the appropriate and complete risk analysis, evaluation and testing of the products with respect to the relevant specific application or use thereof. Neither Schneider Electric Industries SAS nor any of its affiliates or subsidiaries shall be responsible or liable for misuse of the information contained herein.

	circuit
Input impedance	12 kOhm (IB...IG used as analogue input circuit) 12 kOhm (IB...IG used as discrete input circuit) 7.4 kOhm (I1...IA and IH...IR discrete input circuit)
Number of outputs	8 relay output(s)
Output voltage limits	24...250 V AC (relay output) 5...30 V DC (relay output)
Contacts type and composition	NO for relay output
Output thermal current	8 A for all 8 outputs (relay output)
Electrical durability	500000 cycles AC-12 at 230 V, 1.5 A for relay output conforming to EN/IEC 60947-5-1 500000 cycles AC-15 at 230 V, 0.9 A for relay output conforming to EN/IEC 60947-5-1 500000 cycles DC-12 at 24 V, 1.5 A for relay output conforming to EN/IEC 60947-5-1 500000 cycles DC-13 at 24 V, 0.6 A for relay output conforming to EN/IEC 60947-5-1
Switching capacity in mA	>= 10 mA at 12 V (relay output)
Operating rate in Hz	0.1 Hz (at Ie) for relay output 10 Hz (no load) for relay output
Mechanical durability	10000000 cycles (relay output)
[Uimp] rated impulse withstand voltage	4 kV conforming to EN/IEC 60947-1 and EN/IEC 60664-1
Clock	With
Response time	10 ms (from state 0 to state 1) for relay output 5 ms (from state 1 to state 0) for relay output
Connections - terminals	Screw terminals, clamping capacity: 1 x 0.2...1 x 2.5 mm <sup>2</sup> AWG 25...AWG 14 semi-solid Screw terminals, clamping capacity: 1 x 0.2...1 x 2.5 mm <sup>2</sup> AWG 25...AWG 14 solid Screw terminals, clamping capacity: 1 x 0.25...1 x 2.5 mm <sup>2</sup> AWG 24...AWG 14 flexible with cable end Screw terminals, clamping capacity: 2 x 0.2...2 x 1.5 mm <sup>2</sup> AWG 24...AWG 16 solid Screw terminals, clamping capacity: 2 x 0.25...2 x 0.75 mm <sup>2</sup> AWG 24...AWG 18 flexible with cable end
Tightening torque	0.5 N.m
Overvoltage category	III conforming to EN/IEC 60664-1
Product weight	0.38 kg

## Environment

immunity to microbreaks	<= 10 ms
product certifications	CSA C-Tick GL GOST UL
standards	EN/IEC 60068-2-27 Ea EN/IEC 60068-2-6 Fc EN/IEC 61000-4-11 EN/IEC 61000-4-12 EN/IEC 61000-4-2 level 3 EN/IEC 61000-4-3 EN/IEC 61000-4-4 level 3 EN/IEC 61000-4-5 EN/IEC 61000-4-6 level 3
IP degree of protection	IP20 (terminal block) conforming to IEC 60529 IP40 (front panel) conforming to IEC 60529
environmental characteristic	EMC directive conforming to EN/IEC 61000-6-2 EMC directive conforming to EN/IEC 61000-6-3 EMC directive conforming to EN/IEC 61000-6-4 EMC directive conforming to EN/IEC 61131-2 zone B Low voltage directive conforming to EN/IEC 61131-2
disturbance radiated/conducted	Class B conforming to EN 55022-11 group 1
pollution degree	2 conforming to EN/IEC 61131-2
ambient air temperature for operation	-20...40 °C in non-ventilated enclosure conforming to IEC 60068-2-1 and IEC 60068-2-2 -20...55 °C conforming to IEC 60068-2-1 and IEC 60068-2-2
ambient air temperature for storage	-40...70 °C
operating altitude	2000 m
altitude transport	<= 3048 m
relative humidity	95 % without condensation or dripping water

## Compact and Modular Smart Relays

### Mounting on 35 mm/1.38 in. DIN Rail

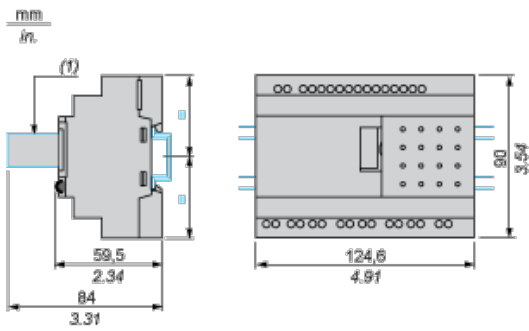

(1) With SR2USB01 or SR2BTC01

### Screw Fixing (Retractable Lugs)

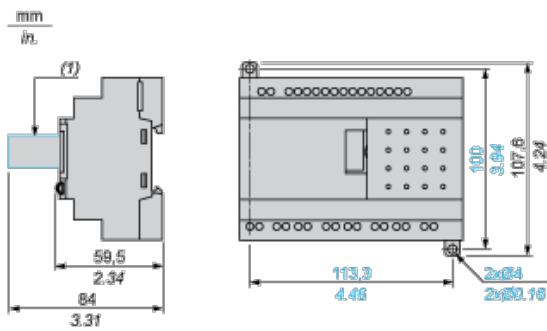

(1) With SR2USB01 or SR2BTC01

### Position of Display

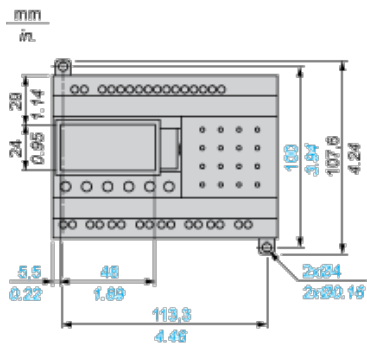

## Compact and Modular Smart Relays

### Connection of Smart Relays on DC Supply

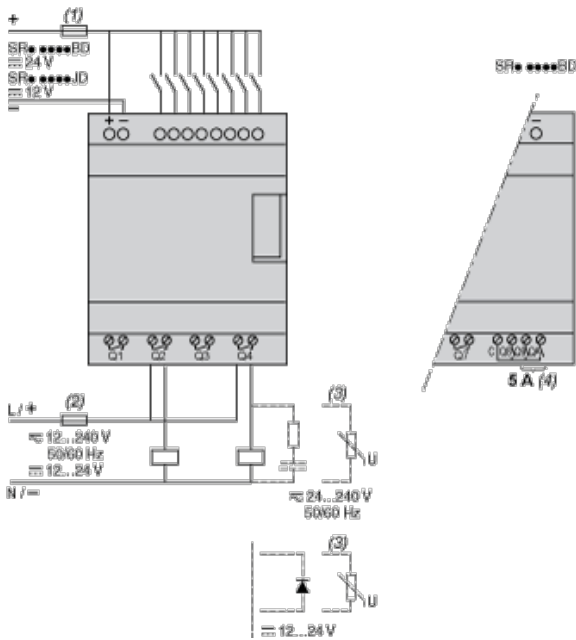

- (1) 1 A quick-blow fuse or circuit-breaker.
- (2) Fuse or circuit-breaker.
- (3) Inductive load.
- (4) Q9 and QA: 5 A (max. current in terminal C: 10 A).

### Discrete Input Used for 3-Wire Sensors

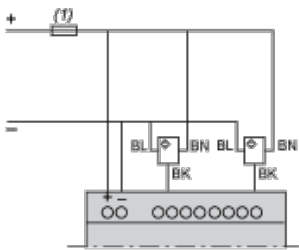

- (1) 1 A quick-blow fuse or circuit-breaker.

## Compact and Modular Smart Relays

### Electrical Durability of Relay Outputs

(in millions of operating cycles, conforming to IEC/EN 60947-5-1)

DC-12 (1)

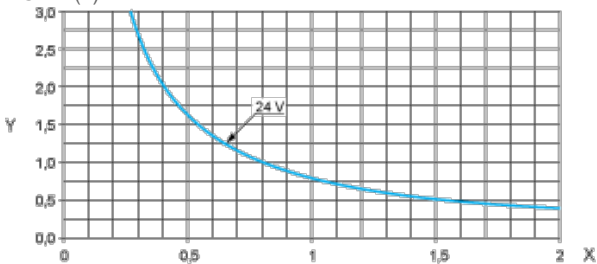

X: Current (A)

Y: Millions of operating cycles

- (1) DC-12: control of resistive loads and of solid state loads isolated by opto-coupler,  $L/R \leq 1$  ms.

DC-13 (1)

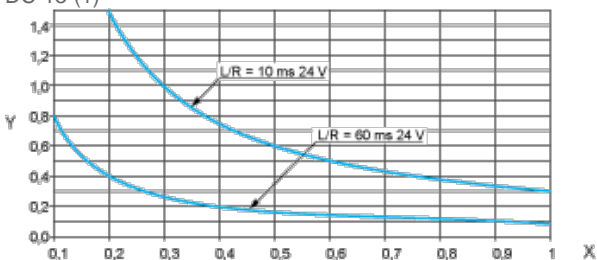

**X:** Current (A)

**Y:** Millions of operating cycles

**(1)** DC-13: switching electromagnets,  $L/R \leq 2 \times (U_e \times I_e)$  in ms,  $U_e$ : rated operational voltage,  $I_e$ : rated operational current (with a protection diode on the load, DC-12 curves must be used with a coefficient of 0.9 applied to the number in millions of operating cycles).