

# Catalogue No: **V7-EA35**

## END CLAMP STANDARD FOR VH7

Termination and Wiring Systems > Terminals and Pre-Wired Cables > Terminals - Screw > Sprecher + Schuh Screw Type Terminals V7-W > Accessories for V7 Terminals > End Clamps



### End Clamp Standard For V7



- Designed for ease of wiring, secure connections and durability
- Comprehensive range, offering a wide array of terminal types for most circuits and functions
- Terminals accommodate a full range of wire sizes from 0.5 to 70mm<sup>2</sup> wire cross section
- Cone shaped guide allows easy wire insertion
- Specialty terminals including two-level, grounding, diode, isolating, fuse, sensor and thermocouple terminals
- International approvals, UL recognized, IEC and CSA certified.

Representative Photo Only  
(actual product may vary based on configuration selections)

#### SPECIFICATIONS

Product Series	V7
Component Type Termination Wiring	End Anchor/ retainers
Package Quantity	50 qty

#### REFERENCES

IECEX Certificate	-
Supplier Declaration of Conformity:	-
Installation Guide:	-
User Manual:	-
Manufacturer Datasheet:	-
Manufacturer Catalogue & Product Selection:	<a href="#">V7EA35_Manufacturer Catalogue</a>

Catalogue No: **V7-EA35**

**END CLAMP STANDARD FOR VH7**

Termination and Wiring Systems > Terminals and Pre-Wired Cables > Terminals - Screw > Sprecher + Schuh Screw Type Terminals V7-W > Accessories for V7 Terminals > End Clamps

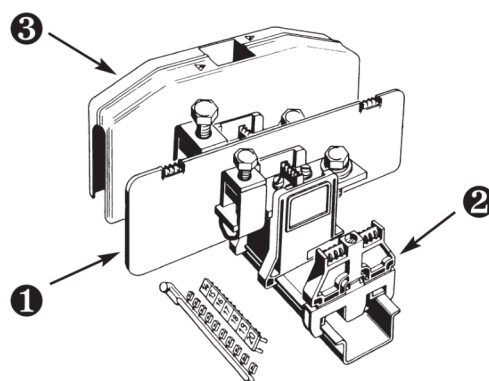

Technical Diagram