

Catalogue No: **TZS-40**

ELR TOROID CLOSED CORE 40mm

Power Distribution and Protection > Earth Leakage Protection > Earth Leakage Relays > Terasaki TZS range of Earth Leakage Relays and Toroids > TZS Earth Leakage Toroid



Earth Leakage Toroid to suit TZS relay. 40mm internal diameter

- Suits TZS Series Earth Leakage Relays
- Internal diameter 15-100 mm
- Closed core models



Representative Photo Only
(actual product may vary based on configuration selections)

SPECIFICATIONS

Product Series	TZS
Component Type Power Distribution & Protection	Toroid
Component Type Transformer	Closed-core Transformer
Details, Transformer	Suits TZS range of earth leakage relays
I _e , Rated Operational Current, max	257 A _{max}
I _{Δn} , Leakage Current, Min	30 mA
Diameter, Internal	40 mm
Mounting	Screw Fixing
Terminal Type	Screw Terminal(s)
Wire / Conductor Size (Max)	80 mm ²
Width	130 mm
Height	113 mm
Depth	30 mm
Weight	0.7 kg

REFERENCES

IECEx Certificate	-
Supplier Declaration of Conformity:	-
Installation Guide:	-
User Manual:	-
Manufacturer Datasheet:	-
Manufacturer Catalogue & Product Selection:	-

Catalogue No: **TZS-40**

ELR TOROID CLOSED CORE 40mm

Power Distribution and Protection > Earth Leakage Protection > Earth Leakage Relays > Terasaki TZS range of Earth Leakage Relays and Toroids > TZS Earth Leakage Toroid

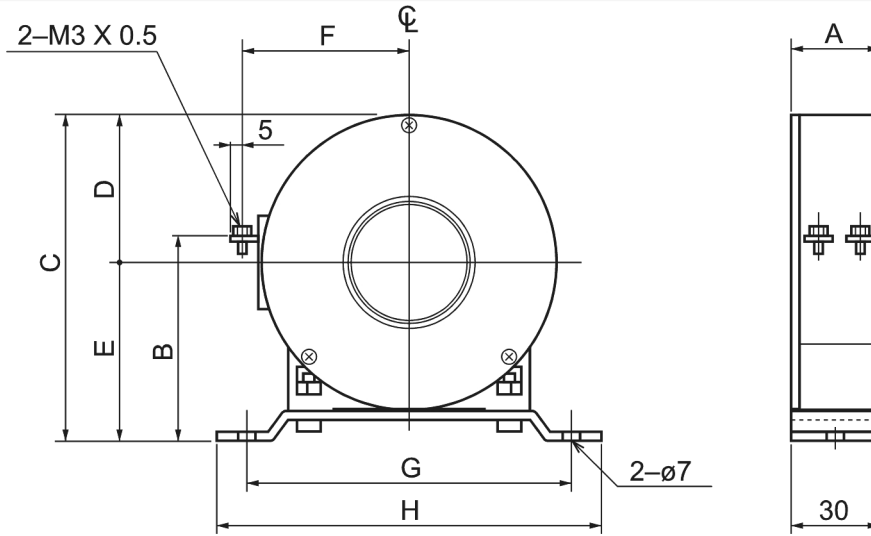

ZCT Type	ød	A	B	C	D	E	F	G	H
TZS-40	40	30	71	113	51	62	57	110	130
TZS-68	68	42	85	141	65	76	70	134	150
TZS-100	100	45	105	181	85	96	90	150	170

Dimension Diagram