



Representative Photo Only
(actual product may vary based on configuration selections)

Padlockable Cover For D7 Operators

- D7 pilot devices offer maximum flexibility and a wide choice for all 22.5mm operator applications with all type (e-stops, selector switches, pushbuttons, pilot lights and more), colour and contact configurations.
- Aesthetically appealing and modularly designed to make assembly and interchangeability easy.
- Operators exhibit low profile and stylish appearance while maintaining the rugged performance necessary for demanding environments
- D7P is a plastic operator with a captive black plastic front bezel. Constructed of high-grade thermoplastics, the D7P is suitable for almost all environments and strong chemical resistance.
- D7M has a die-cast zinc housing and mounting ring for rugged durability. Finished with corrosion resistant chrome plating, the D7M also features a captive shiny metal bezel for a polished appearance.

SPECIFICATIONS

Product Series	D7A
Component Type Pushbutton and Pilot Lights	Accessories - General
Compatible Product Series'	D7 22.5mm Control & Indication
Details, compatible product series	Used on Flush, Extended and Guarded Momentary and Maintained Operators, and Standard Knob Selector Switch Operators.
RoHS Approved	Yes
CE Marked	Yes
Relative humidity, min	50 %RH
Relative Humidity, Max	95 %RH
IP Rating	IP66 IP65
Shock Acceleration (Max.)	100 g
Shock Duration (Max.)	11 ms
Vibration Acceleration (Max.)	10 m/s ²
Vibration Displacement (Peak to Peak Max.)	1.52 mm
Vibration Frequency, Operational (Max.)	2000 Hz
Vibration Duration (Max.)	180 min
Standards Compliance	NEMA ICS-5 UL 508 EN 60947-1 EN 60947-5-1 EN 60947-5-5 EN 418
Certifications	UL UR CSA CCC CE
Shipping Approvals	RINA (Registro Italiano Navale) ABS (American Bureau of Shipping) Lloyd's Register of Shipping

Catalogue No: **D7-AL01**

PADLOCKABLE COVER FOR FLUSH/EXT/GUARD/LATCH/SEL D7

Operator Control Devices > Pushbuttons and Control Switches > Pushbuttons and Pilot Lights > Sprecher + Schuh D7
Pushbuttons and Pilot Lights > D7 Accessories > Padlockable Cover



REFERENCES

IECEX Certificate -

Supplier Declaration of
Conformity: -

Installation Guide: -

User Manual: -

Manufacturer Datasheet: [D7AL01_Manufacturer Datasheet](#)

Manufacturer Catalogue
& Product Selection: -

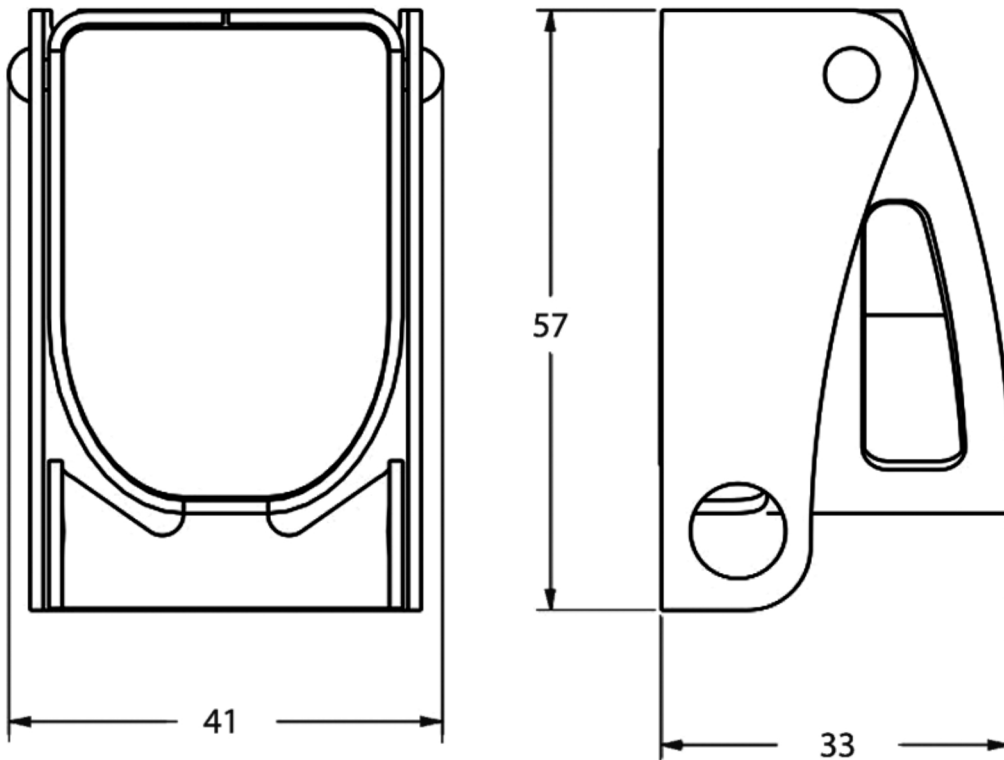

Dimension Diagram