

**CLIPSAL**<sup>®</sup>

by **Schneider Electric**

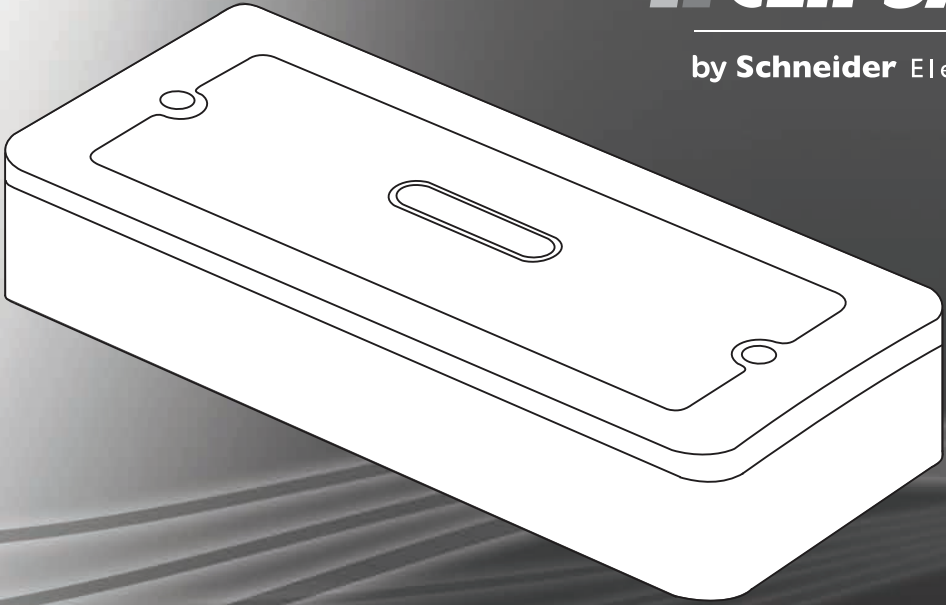

**C-Bus<sup>®</sup>**  
**C-Bus 8-Channel**  
**Safe Extra Low Voltage Relay**  
**L5108RELVP**



**Installation Instructions**

# Contents

<b>1.0</b>	<b>Product Range</b>	<b>3</b>
<b>2.0</b>	<b>Description</b>	<b>3</b>
<b>3.0</b>	<b>Important Notes</b>	<b>4</b>
<b>4.0</b>	<b>Mounting Instructions</b>	<b>5</b>
<b>5.0</b>	<b>Wiring Instructions</b>	<b>6</b>
	5.1 Connecting the Load Wiring	6
	5.2 C-Bus Network Connection	7
<b>6.0</b>	<b>Status Indicators and Buttons</b>	<b>7</b>
	6.1 C-Bus Indicator	7
	6.2 Unit Indicator	8
	6.3 Local Toggle Buttons and Indicators	8
<b>7.0</b>	<b>C-Bus Requirements</b>	<b>9</b>
	7.1 C-Bus Clock	9
	7.2 C-Bus Network Burden	10
	7.3 Power Up Load Status	10
	7.4 C-Bus Programming	10
<b>8.0</b>	<b>Electrical Specifications</b>	<b>11</b>
<b>9.0</b>	<b>Mechanical and Environmental Specifications</b>	<b>12</b>
<b>10.0</b>	<b>Standards Complied</b>	<b>13</b>
<b>11.0</b>	<b>Warranty</b>	<b>14</b>

---

## 1.0 Product Range

Catalogue No.	Channels	Channel Rating	On-Board C-Bus Power Supply
L5108RELVP	8	2A @ 30 V d.c. 2A @ 30 V a.c. RMS	No

**Note:** The relay outputs are suitable for inductive and resistive loads.

## 2.0 Description

The extra low-voltage relay unit is a C-Bus output device that controls eight extra low voltage relay channels. The unit is powered from the C-Bus network and requires no other power source. The unit can be daisy chained or placed at the end of a C-Bus network.

This product is suitable for switching loads such as irrigation solenoids and SELV air conditioning dampers as well as SELV pulse signal control into third party products.

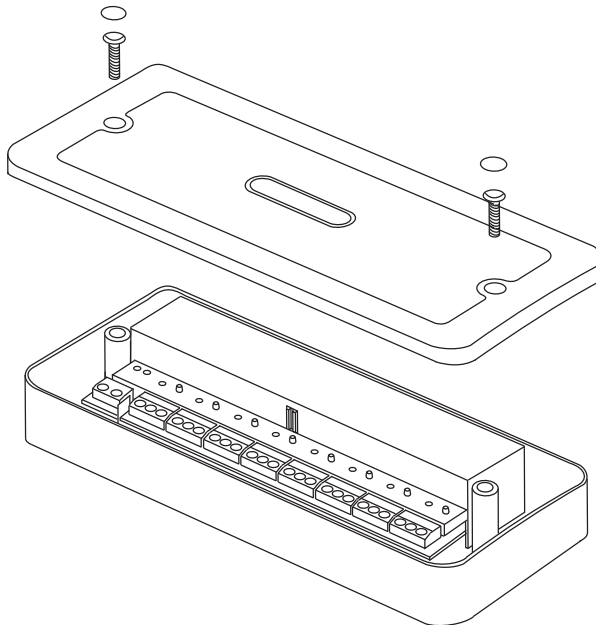

Figure 1. L5108RELVP 8-Channel Low Voltage Relay Unit

For ease of programming, the C-Bus Toolkit Software GUI for the relay unit is similar to other output devices. The unit can be programmed using learn mode and the L5108RELV is supported and can be modelled by C-Gate.

Local toggle buttons allow individual channels to be switched locally (overriding the current C-Bus state). Indicator lamps show the status of the C-Bus network connection and the relay channel.

The voltage-free relay contacts can be wired normally open (N/O) or normally closed (N/C). The relay channels handle AC or DC voltage switching applications up to the rated current and voltage. The switch state can be changed as often as 1 second.

Applications that require simultaneous switching of two channels must follow the pairing shown in the table below. For example, you may connect devices to relay channels 1 and 2, but not to 1 and 3.

<b>Relay pairs for simultaneous switching applications</b>			
1 and 2	3 and 4	5 and 6	7 and 8

The relay unit can be installed on any solid surface using mounting screws or keyholes. The unit operates in harsh environments up to 50 degrees C ambient temperature and has an IP51 rating.

### **3.0 Important Notes**

- Do not connect the C-Bus terminals to building power. The C-Bus network uses Category 5e (CAT.5e) unshielded, twisted pair (UTP) network cable.
- The relay unit has six (6) knockouts for cable placement. Seal the cable entry areas after installation to prevent entry of dust or other debris.
- The use of software not provided by Clipsal Integrated Systems (CIS) in conjunction with the installation of these products may void any warranties applicable to the hardware.
- To enhance system immunity to power surges, it is strongly recommended that you install overvoltage equipment such as the Clipsal 970 at the switchboard.

## 4.0 Mounting Instructions

The L5108RELVP unit is designed for indoor use. Choose a mounting location that provides protection from moisture, extreme temperatures and direct sunlight.

Do not locate C-Bus network cables near building power cables. Refer to local wiring rules in your region.

In order to protect the PCB from damage, do not remove the PCB cover. To mount the unit use the four (4) interior mounting holes or the two (2) keyholes. Mounting screws are provided with this product. Use the type of retaining hardware that is appropriate for the mounting surface. See Figure 2 for mounting hole locations.

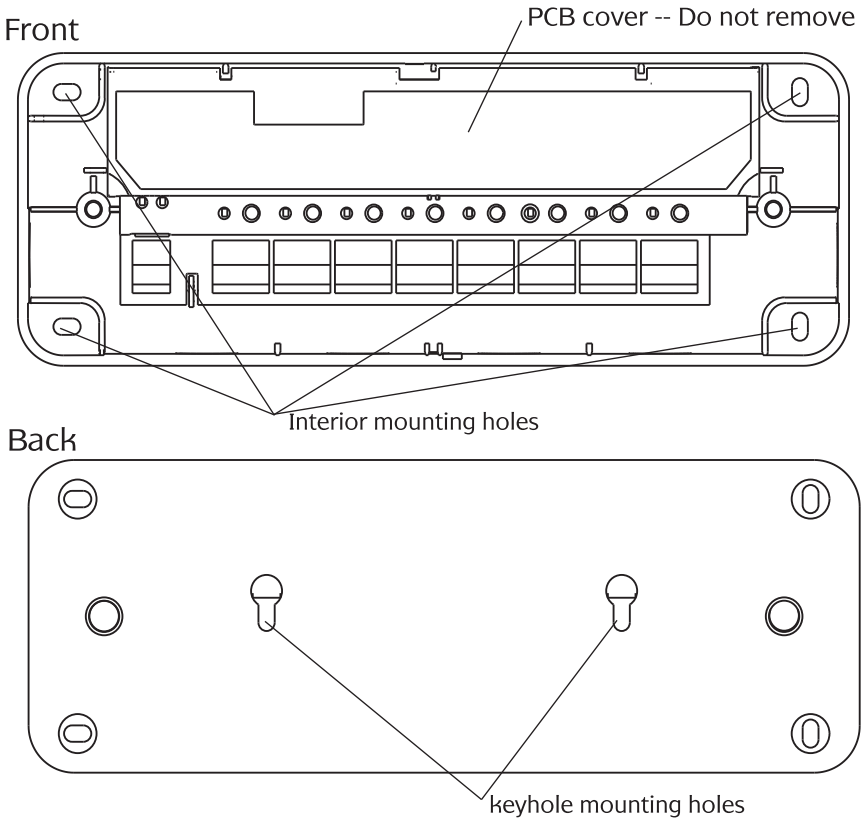

Figure 2. Mounting the Relay Unit

## 5.0 Wiring Instructions

### 5.1 Connecting the Load Wiring

Follow these guidelines when installing the relay unit:

- Units are capable of handling up to eight (8) channels of 2A switched loads. Ensure you consider the load current when selecting cables.
- Fix the load and C-Bus cables in the distribution area using cable ties or trunking, as required by local wiring rules.
- Do not use excessive force when making wiring connections.
- When attaching network wiring, twist the wire ends together or use bootlace crimp connectors.

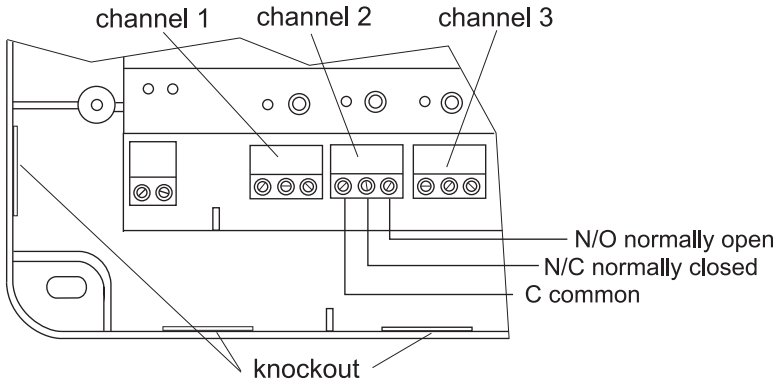

L5108RELV 8-Channel Relay      S/N \_\_\_\_\_ Location \_\_\_\_\_

1	2	3	4	5	6	7	8
<input type="checkbox"/> N/O <input type="checkbox"/> N/C	<input type="checkbox"/> N/O <input type="checkbox"/> N/C	<input type="checkbox"/> N/O <input type="checkbox"/> N/C	<input type="checkbox"/> N/O <input type="checkbox"/> N/C	<input type="checkbox"/> N/O <input type="checkbox"/> N/C	<input type="checkbox"/> N/O <input type="checkbox"/> N/C	<input type="checkbox"/> N/O <input type="checkbox"/> N/C	<input type="checkbox"/> N/O <input type="checkbox"/> N/C

Figure 3. Worksheet for the Load Wiring of the 8-Channel Relay Unit

## 5.2 C-Bus Network Connection

Connect the C-Bus network using the screw type terminals (capable of holding three twisted pairs). The relay unit can be daisy chained to other C-Bus devices or it can be located at the end of the C-Bus network.

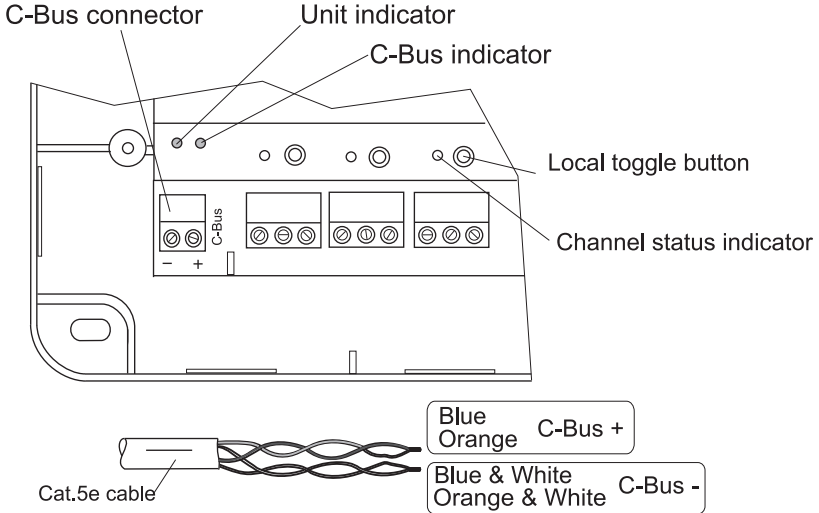

Figure 4. C-Bus Network cable conductor assignments

The Clipsal catalogue numbers for the C-Bus Cat.5e UTP cable are 5005C305B (solid) and 5005C305BST (stranded).

## 6.0 Status Indicators and Buttons

### 6.1 C-Bus Indicator

The 'C-Bus' indicator shows the status of the C-Bus network at the unit. A continuous orange light indicates sufficient network voltage and a valid C-Bus clock signal are present.

A flashing light indicates a marginal network voltage, usually due to insufficient power supplies to support the connected devices.

The indicator is off if no C-Bus clock is present. Refer to Table 1.

Indicator Status	Meaning
On	Power is on and functional
Flashing	There is insufficient power to support the C-Bus network
Off	C-Bus clock signal is not present or power is not present

Table 1. The 'C-Bus' indicator

Further debugging of possible network problems can be achieved using the Clipsal C-Bus Network Analyser tool (5100NA).

## 6.2 Unit Indicator

The 'Unit' indicator shows the status of the relay unit. A continuous orange light indicates normal operation. A flashing light with a 90% duty cycle indicates a local toggle button has been used to perform a local override.

Indicator Status	Meaning
On	Normal operation
Flashing	A local toggle button was pressed
Off	No power is present

Table 2. The 'Unit' indicator

## 6.3 Local Toggle Buttons and Indicators

The local toggle buttons provide individual channel override capability. The buttons are located on the PCB cover. Each button illuminates an LED when its respective relay is in the energised state.

Using local toggle buttons overrides the normal C-Bus commands such as those issued by input units. By default, once a channel is in local override mode, further relevant C-Bus commands issued by input and control units will override the local override state. This feature can be disabled in software so that the unit ignores all relevant C-Bus commands when it is in local override mode.

Local toggle buttons perform different functions depending on how they are pressed. This is summarised in Table 3.



<b>Operation</b>	<b>Function</b>
Quick-press	A single quick-press toggles the state of a channel
Double quick-press	Two quick-presses in quick succession return the channel to the C-Bus network level
Long press	Pressing any of the local toggle buttons for 1 second or more returns all channels to the C-Bus network level

Table 3. Local toggle button functions

Note that double quick-press and long press operations only apply when the unit/channel is in local override mode. C-Bus commands received by the unit will (by default) override local toggle changes. In this case, only the channel associated with the received commands will revert to the current C-Bus network state.

Further information about programming C-Bus units is provided at the Clipsal Integrated Systems web site (<http://www.clipsal.com/cis>).

## **7.0 C-Bus Requirements**

### **7.1 C-Bus System Clock**

The relay unit incorporates a software-selectable C-Bus system clock. The clock synchronises data communications over the network. At least one active clock is required on each C-Bus network for successful communication.

No more than three units on any C-Bus network should have the clock feature enabled (having the potential to be the active network clock). The clock 'enabled' option on the relay unit is normally checked. To disable the clock using C-Bus Toolkit Software, navigate to the unit's 'Global' tab and uncheck the relay unit's clock.

## **7.2 C-Bus Network Burden**

One network burden is normally required to ensure correct operation of each C-Bus network. The relay unit incorporates a software-selectable burden. The burden can be enabled from the unit's 'Global' tab in C-Bus Toolkit software, but only if the C-Bus system clock is enabled and the Unit Address is set to 1.

The Network window of a C-Bus Toolkit project provides a summary of a C-Bus network based on the units added to the Database. This can be helpful in determining whether or not a burden is required on a particular network.

## **7.3 Power-Up Load Status**

When the L5108RELVP powers up, the relays will be in the de-energised state. In case C-Bus power is lost, the unit sets the relay channels to the de-energised state before shutting down. When C-Bus power is restored, the relays power up in the de-energised state, regardless of the C-Bus state before power was lost.

## **7.4 C-Bus Programming**

As with other C-Bus units, an L5108RELVP SELV Relay unit must be programmed before it will function as part of a C-Bus network. This can be accomplished using Learn Mode. However, using C-Bus Toolkit software provides a greater level of flexibility and customisation.

C-Bus Toolkit software can be downloaded from the Clipsal Integrated Systems web site ([www.clipsal.com/cis](http://www.clipsal.com/cis)). Further information about programming C-Bus units is provided at this site.

## 8.0 Electrical Specifications

Parameter	L5108RELV
C-Bus network supply voltage	15 to 36 V DC @ 32 mA required for programming and operation
Max. units per C-Bus network	50
C-Bus connections	2 wire, twisted pair
Warm up time	5 seconds
Load Rating per relay channel	2A at 30 V d.c. max or 30V a.c. RMS Suitable for resistive and inductive loads
Contact type	Voltage Free, SPDT (changeover)
Relay terminal connections	C common N/O normally open N/C normally closed
Types of electrical connection	Fixed load terminal for 1 x 1.0mm <sup>2</sup> wire per tunnel (13 AWG)  Removable C-Bus terminal block
Switching rate	0.5 sec per operation, 1 or 2 relays per operation

## 9.0 Mechanical and Environmental Specifications

Parameter	Description
Dimensions (W×H×D)	220 mm x 80 mm x 39 mm
Weight	330 g
Mounting mode	Surface; 4 mounting screw holes and keyhole mount
EMC Environment	Environment A
IP Rating	IP51
Operating ambient temperature	0 - 50 degrees C
Storage temperature	0 - 60 degrees C
Operating Humidity	10 - 90 percent, non condensing

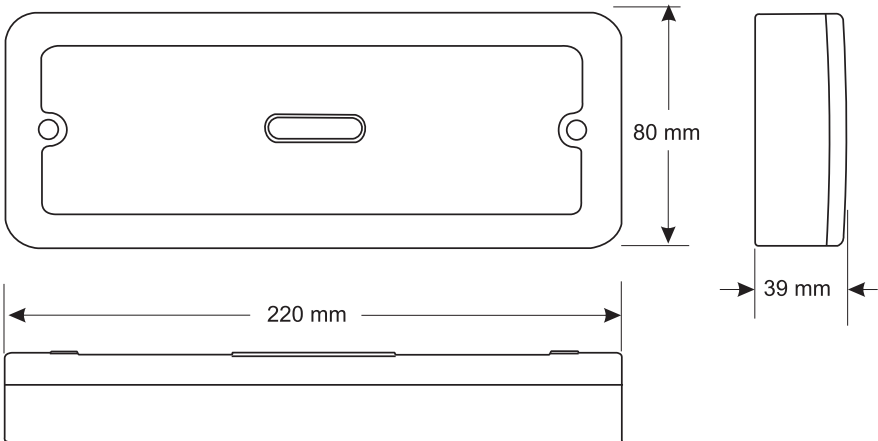

## 10.0 Standards Complied

### ***DECLARATIONS OF CONFORMITY***

Model L5108RELV product complies with the following:

#### ***Australian/New Zealand EMC & Electrical Safety Frameworks and Standards***

<b>Regulation</b>	<b>Standard</b>	<b>Title</b>
EMC (C-Tick)	AS1044, AS/NZS 61000-3-2	RFI Emissions Standard
Electrical Safety	AS/NZS 3100  AS/NZS 61558-1	General Requirements for Electrical Equipment  Safety of Power Supplies and Transformers

#### ***European Directives and Standards***

<b>European Council Directive</b>	<b>Standard</b>	<b>Title</b>
EMC Directive 89/336/EEC	EN 55014 EN 60669-2-1 Clause 26.1  EN 60669-2-1 Clause 26.2	RFI Emissions Standard Immunity to ESD, RFI, EFT, Surge Voltages, Voltage Dips and Interruptions RF and Low Frequency Emissions

#### ***Other International Directives and Standards***

<b>Regulation</b>	<b>IEC Standard</b>	<b>Title</b>
EMC	60669-2-1 Clause 26.1  60669-2-1 Clause 26.2	Immunity to ESD, RFI, EFT, Surge Voltages, Voltage Dips and Interruptions RF and Low Frequency Emissions

## 11.0 Warranty

The C-Bus 8-Channel SELV Relay carries a two-year warranty against manufacturing defects.

### Warranty Statement

- 1) The benefits conferred herein are in addition to, and in no way shall be deemed to derogate; either expressly or by implication, any or all other rights and remedies in respect to Clipsal Integrated Systems Product, which the consumer has under the Commonwealth Trade Practices Act or any other similar State or Territory Laws.
- 2) The warrantor is Clipsal Pty Ltd, with registered offices in all Australian States.
- 3) This Clipsal Integrated Systems Product is guaranteed against faulty workmanship and materials for a period of two (2) years from the date of installation.
- 4) Clipsal Australia Pty Ltd reserves the right, at its discretion, to either repair free of parts and labour charges, replace or offer refund in respect to any article found to be faulty due to materials, parts or workmanship.
- 5) This warranty is expressly subject to the Clipsal Integrated Systems Product being installed, wired, tested, operated and used in accordance with the manufacturer's instructions.
- 6) All costs of a claim shall be met by Clipsal Australia Pty Ltd, however should the product that is the subject of the claim be found to be in good working order, all such costs shall be met by the claimant.
- 7) When making a claim, the consumer shall forward the Clipsal Integrated Systems Product to the nearest office of Clipsal Australia Pty Ltd with adequate particulars of the defect within 28 days of the fault occurring. The product should be returned securely packed, complete with details of the date and place of purchase, description of load, and circumstances of malfunction.

For all warranty enquiries, contact your local Clipsal sales representative. The address and contact number of your nearest Clipsal Australia office can be found at <http://www.clipsal.com/locations> or by telephoning Technical Support 1 300 722 247 (CIS Technical Support Hotline).



## Technical Support and Troubleshooting

For further assistance in using this product, consult your nearest Clipsal Integrated Systems (CIS) Sales Representative or Technical Support Officer.

Technical Support Contact Numbers	
Australia	1300 722 247 (CIS Technical Support Hotline)
New Zealand	0800 888 219 (CIS Technical Support Hotline)
Northern Asia	+852 2484 4157 (Clipsal Hong Kong)
South Africa	011 314 5200 (C-Bus Technical Support)
Southern Asia	+603 7665 3555 Ext. 236 or 242 (CIS Malaysia)
United Kingdom	0870 608 8 608 (Schneider Electric Support)

Technical Support email: [cis\\_support@clipsal.com.au](mailto:cis_support@clipsal.com.au)

---

### Product of Clipsal Australia Pty Ltd

A member of Schneider Electric

**clipsal.com**

Contact us [clipsal.com/feedback](http://clipsal.com/feedback)

### National Customer Care Enquiries

**Tel 1300 2025 25**

**Fax 1300 2025 56**

Clipsal Australia Pty Ltd reserves the right to change specifications, modify designs and discontinue items without incurring obligation and whilst every effort is made to ensure that descriptions, specifications and other information in this catalogue are correct, no warranty is given in respect thereof and the company shall not be liable for any error therein.

© Clipsal Australia Pty Ltd.

The identified trademarks and copyrights are the property of Clipsal Australia Pty Ltd unless otherwise noted.