

Accessories

Rubber cable sleeves

- For direct mounting
- Complete with template

851106 1

For use as a sealing gland on cable end boxes.

Max. Ø cable: 75 mm

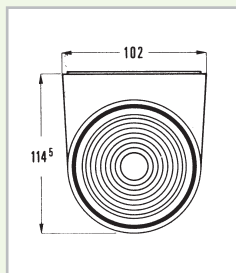
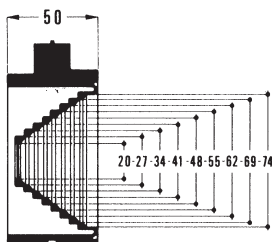

Air vents IP44

Two air vents must be mounted per enclosure to ensure sufficient air circulation and prevent water condensation.

Complete with template and screws.

The air vents are preferably mounted in the upper and lower part of the base.

833677 1

Set of 2 pieces in polyamide.

RAL 7035

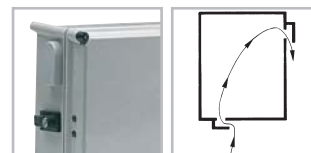

Bridges

Make heavy connections easier whilst guaranteeing that the original degree of protection is maintained.

851103 1

Fits the 300 mm side.

851112 1

Fits the 370 mm side.

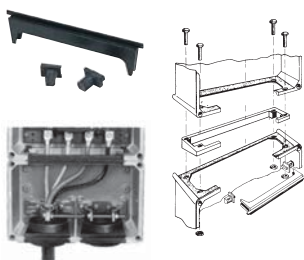

Pole mounting

- At the rear of enclosure, C-profiles are installed.

- Around the pole, a fixation (holding) band is installed. On the C-profile, clamps are placed to catch the holding band securely.

890510 1

Set of 2 C-profiles for side 300 and 370 mm (fixation band not included).

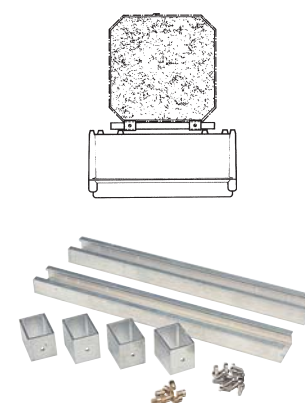

Safety locks with handle*

Complete with drilling template, keys and mounting hardware.

852020 1

2 keys V 2432E

Safety locks without handle

852021 1

Square key 8 mm

852022 1

Triangular key 8 mm

852024 1

Triangular key 11 mm

852023 1

Double-bit yale key 3 mm



* Not usable with hinged cover.

Mounting brackets

851266 1

Set of 4 pieces in glass fibre reinforced polyamide

- For external fixing points.
- Direct fixing through the four corner holes of the enclosure.
- If extension frames are to be used, the mounting brackets shall be mounted before the frames.
- Maximum permissible component weight: 150 kg.

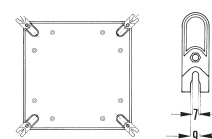

852025 1

Set of 4 pieces in stainless steel (type 304)

- For extremely severe working conditions.
- For band iron fixation to round poles.
- The four brackets are mounted directly at the rear of the box in reinforcements provided for that purpose.
- Fixing by M4 threaded bushes (supplied).
- Maximum permissible component weight: 150 kg.

