



**FEATURES**

Heavy duty formed steel (1.6mm) automatic hand dryer with sensor operation. Large fan and motor assembly provides a high performance dryer designed for high traffic areas and heavy use. Easy installation with tamper-proof locking.

**INSTALLATION OPTIONS**

Electrical connection by cord & plug (as supplied). Can be direct wired by an electrician. Refer to Operating Instructions and Parts Manual for detailed instructions.

**OPERATION**

Activate dryer by placing hands under sensor. Dryer automatically shuts off after user removes hands from sensor zone.

**SPECIFICATION**

- Electrical Supply: AC, 220-240V 50/60Hz, 2400 Watt, 10A
- Motor: 200 Watt, Brush Type, Dual Ball Bearings
- RPM: 5,500
- Element: 2200 Watt
- Air Speed: 75.6 km/hr
- Noise Level: 63.4 dB-A @2M
- Drying Time: Under 20 seconds
- Weight: 6.2kg (Shipping 7kg)
- Certificate of Suitability No: Q070423
- Electrical Safety Requirement: AS/NZS 60335.2.23:2004
- Protection category: IPX3

**COVER & NOZZLE OPTIONS**

Unit is supplied in various finishes. Specify finish option by adding appropriate code number suffix:

MODEL	COVER	NOZZLE
HDABWHTSC	White powder coated formed steel, 1.6mm thick	Satin chrome
HDABWHTPC	White powder coated formed steel, 1.6mm thick	Polished chrome
HDABWHTSG	White powder coated formed steel, 1.6mm thick	Silver gloss
HDABSSSSC	Satin stainless steel, 1.6mm thick	Satin chrome
HDABPSSPC	Bright stainless steel, 1.6mm thick	Polished chrome

**WARRANTY**

10 years (first year parts & labour, remaining 9 years parts only). Please refer to our website to view our full warranty statement: [www.asijdmacdonald.com.au](http://www.asijdmacdonald.com.au)

**Autobeam Automatic Hand Dryer** shall be Model No. HDABxxxx as supplied by ASI JD MacDonald.

 All ASI JD MacDonald disabled compliant products when installed must be in accordance with AS1428 to ensure the specified product is complying with all washroom specification requirements.

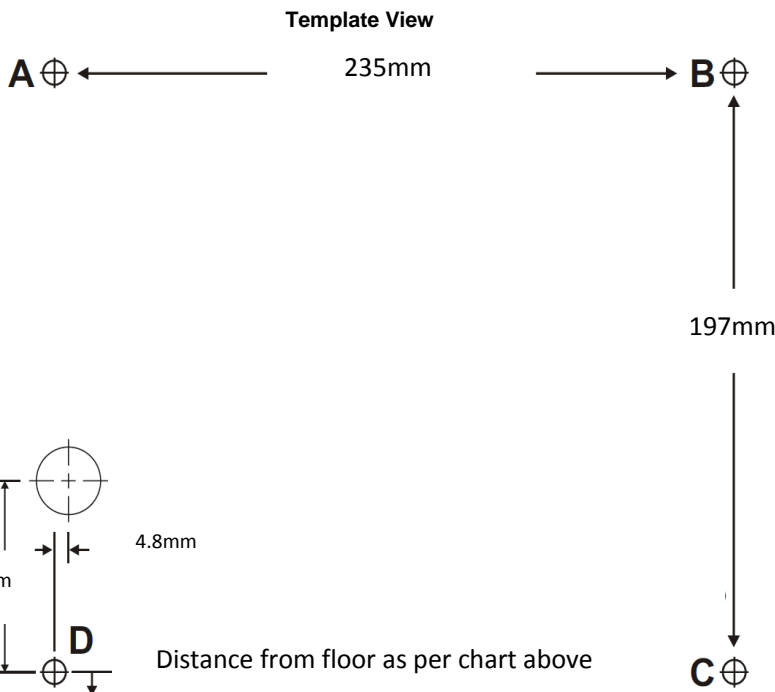
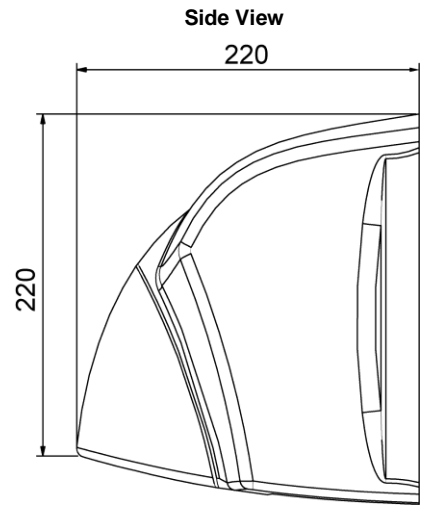
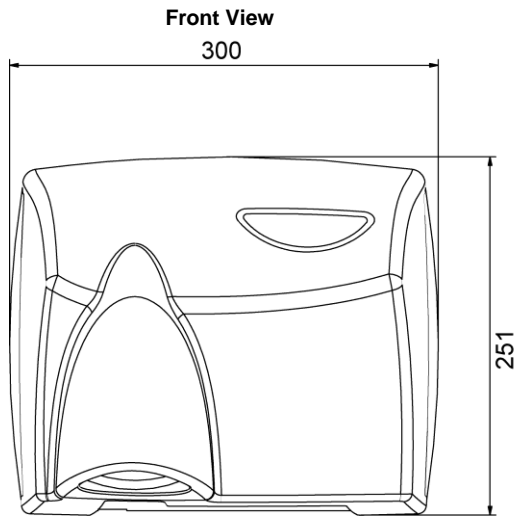

<b>RECOMMENDED INSTALLATION HEIGHTS*</b>	
Men's washroom	1270mm
Women's washroom	1194mm
Children's washroom ages 4-7	889mm
Children's washroom ages 8-10	991mm
Children's washroom ages 11-13	1092mm
Children's washroom ages 14-16	1194mm
Accessible Compliant washroom	1016mm

\*From bottom edge of dryer above finished floor (AFF)

ASI JD MacDONald reserves the right to, and does from time to time, make changes and improvements in design and dimensions. The photographs and line drawings of the products in this flyer are representational only. All dimensions are in millimetres unless otherwise stated.