

**FEATURES**

Heavy duty cast aluminium automatic hand dryer with sensor operation. Large fan and motor assembly provides a high performance dryer designed for high traffic areas and heavy use. Easy installation with tamper-proof locking. Optional swivel nozzle. Made in Australia.

**INSTALLATION OPTIONS**

Electrical connection by cord & plug (as supplied). Can be direct wired by an electrician.

**SPECIFICATION**

- Electrical Supply: AC, 230-240V 50Hz 10A
- Motor: 90 Watt 5000 RPM
- Element: 2310 Watt protected by thermal cut-out
- Air Velocity: 18.5m/s
- Noise Level: 76dB (A)
- Weight: Gross 5.4kg, Shipping 6kg
- Certificate of Suitability No: Q070423
- Electrical Safety Requirement AS/NZS 60335.2.23:2004
- Protection category: IPX3

**FINISH**

White gloss casing with polished chrome nozzle. Designer colours for quantity purchases.

**RECOMMENDED INSTALLATION HEIGHT**

|                                |  |
|--------------------------------|--|
| Men's washroom                 | 1200mm   |
| Women's washroom               | 1150mm   |
| Children's washroom ages 11-15 | 1110mm   |
| Children's washroom ages 5-10  | 850mm  |
| Disabled person's washroom     | 1000mm  |

**WARRANTY**

JD MacDonald Autobeam hand dryer is guaranteed against defective materials and faulty workmanship for 10 years from date of purchase, subject to being installed and maintained in accordance with the Installation and Operating Instructions supplied with the hand dryer.

**Autobeam with Polished Chrome Nozzle** shall be Model No. AUTOBEAM-PC as manufactured by JD MacDonald.

 All JD MacDonald disabled compliant products when installed must be in accordance with AS1428 to ensure the specified product is complying with all washroom specification requirements.

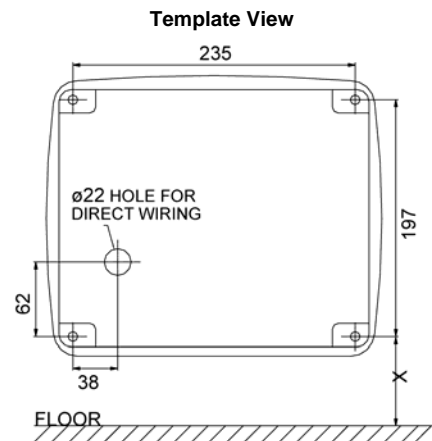
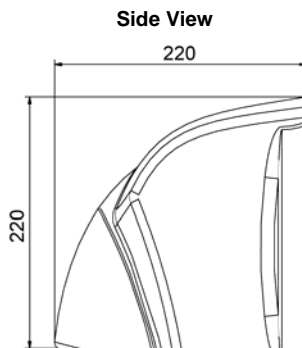
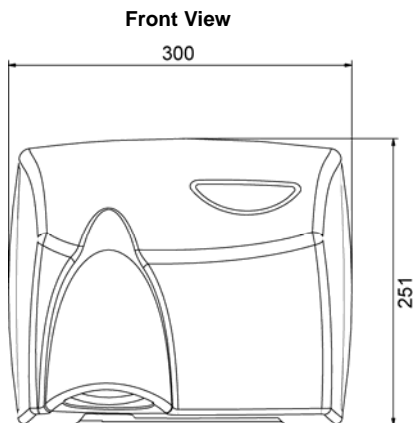

JD MacDonald reserves the right to, and does from time to time, make changes and improvements in design and dimensions. The photographs and line drawings of the products in this flyer are representational only. All dimensions are in millimetres.