



LIFESAVER

240V HEAT ALARM

MODEL LIFHA240



FIXED TEMPERATURE DESIGN THERMAL ALARM

- Interconnects directly with PSA Lifesaver Smoke Alarms as a good supplement to overall fire protection.

FEATURES:

- 57°C fixed temperature design Heat Alarm
- Interconnectable with compatible 240V smoke and CO alarms.
- MAINS power on green Led and red status Led.
- 240V mains power operation, 9VDC battery backup.
- Low battery indication
- Tamper resistant
- 5 year warranty (excludes battery)
- Single Test and Hush button

APPLICATIONS:

- Kitchen Areas
- Garages, cellars, attics, workshops and factory.
- High dust & humidity areas

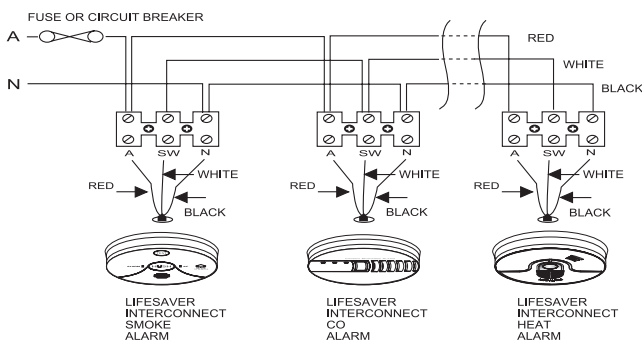

SPECIFICATIONS

Detection Method	Fixed temperature 57°C (thermal sensor)
Sound	85dB at 3 meters
Low Battery Indication	Sounds a "chirp" at 30 - 40 second intervals
Interconnects to	Up to 24
Compatible with	Smoke Alarms: LIFESAVER 5800/2, 5800RL/2, 5800ACF Carbon Monoxide Alarm: LIFESAVER CO240 Isolation Relay: LIFESAVER LIFSAIR
Power Requirement	240 Volt AC 50 Hz sine wave supply
Rating	80mA maximum per alarm
Dimensions	127mm (D) x 50mm (H)
Part Number	LIFHA240
Recommended coverage :	50m ²
Recommended spacing	5.3m
Maximum Distance From Wall	7.7m
Maximum Ceiling Height	6m
Approve to	AS1603.3:2018



Tested & complies to AS 1603.3:2018



FIRE • SECURITY • INTERCOMS

1300 772 776 enquiry@psaproducts.com.au
psaproducts.com.au

