

HILLS™ Ezy Gutter Mount

(Patent Pending)

65cm dishes in wind categories up to W60
80cm dishes in wind categories up to W50

Installation Requirements

Select installation site in consultation with the customer taking the following points into consideration:

- Clear signal path to satellite.
- Structural soundness of the rafters and fascia at the installation point.
- Clear of power lines or other potential hazards.
- Cable run to set top box.
- The mount should not be installed where the joint of a fascia is between 2 rafters. In this situation an adjacent set of rafters should be used.
- The mount is not to be installed where debris from surrounding trees can fall into the gutter.
- The minimum gap between the bottom of the goose neck and the bottom of the gutter must always exceed 30 mm.

Installation Procedure

- 1** Slip three (3) tiles to expose two (2) rafters as per fig1.

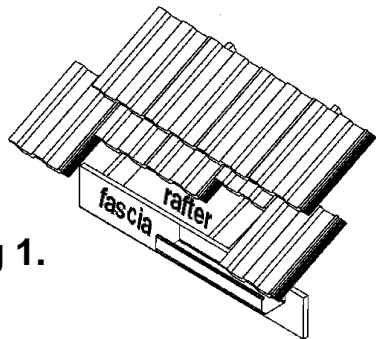

Fig 1.

- 2** Assemble the two sections of the mount as shown in fig 2.

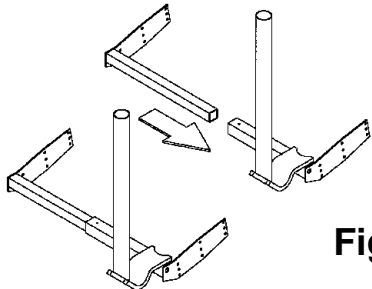

Fig 2.

- 3** Place the assembly into the roof so that both plates are firm against the rafters. Check how the tile sits on the tongue of the mount. If the tongue causes the tile to sit incorrectly, then it may be necessary to notch the fascia to allow the mount to sit lower so that the tongue clears the tile.

If notching is required:

- a) mark the width and position of the tongue on the top of the fascia.....**The width must not exceed 78mm**

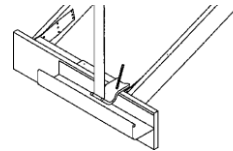

Fig 3.

- b) Make 2 cuts 12mm deep and chisel out between the cuts. **(the cuts must not be deeper than 12mm)**. This cut in the fascia must be done with care - if it is too rough, the risk of water ingress increases.

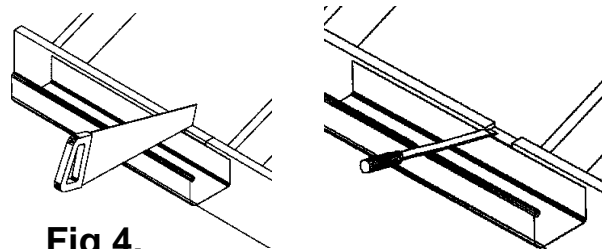

Fig 4.

Note: care should be taken not to damage the gutter which may allow water ingress into the roof space

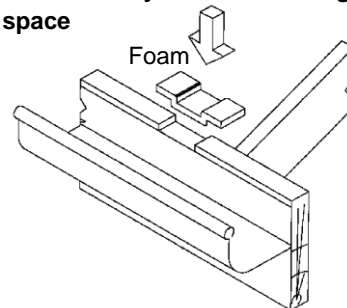

Fig 5.

- 4** Shape foam strip (supplied) to fit into the cut in the Fascia. Reposition the bracket assembly and push down firmly into the foam to seal the cut against water ingress....check vertical with a spirit level.

- 5** Fasten end plates to the rafters

- To fasten the mount in place it is necessary to **use one fastener in each group of 3 holes in the end plates.**
- The hole selected in each group **must be at least 25mm from the edge of the rafter.**
- The 6mm bolt, washer and nut **must be used in the group of holes nearest the fascia.**
- To avoid splitting hard wood rafters it may be necessary to pre-drill for these screws with a 4mm drill bit.

Note: The 6mm bolts must be used on all installations plus at least two of the 14x40 type 17 self drilling wood screws per end.

- 6** Drive the 2 TEK screws into the holes in the large square tube to ensure the two telescoping tubes are locked together. See fig 6

Fig 6.

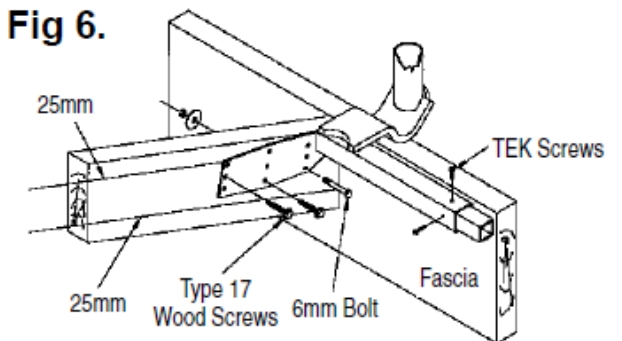

- 7** Reposition the tiles.....the mast install is complete.