

150mm Wall Exhaust Fans

Cat R621/8A
Cat R621/9A

SPECIFICATIONS (at 25°C)

Supply voltage:	220-240V a.c.	□
Frequency:	50Hz	
Rating:	25W (Cat R621/8A)	T
	30W (Cat R621/9A)	
Air displacement:	235m ³ /hour (approx.)	
Dimensions (mm):	218h x 225w x 115d	
Hole cut-out size:	160mm	⚠
IP Rating:	IP34	

FEATURES

These exhaust fans are designed primarily for wall mounting. They may also be ceiling mounted, however this mounting angle may lead to a shorter life span. They may be vented into a cavity wall or into the roof space in the ceiling.

Alternatively, the fan may be ducted through an outside wall (with the addition of ducting and an outside grille). They may also be used for window mounting with the addition of a window mounting kit. These two kits ('wall ducted' and 'window mounting') are available from your usual outlet.

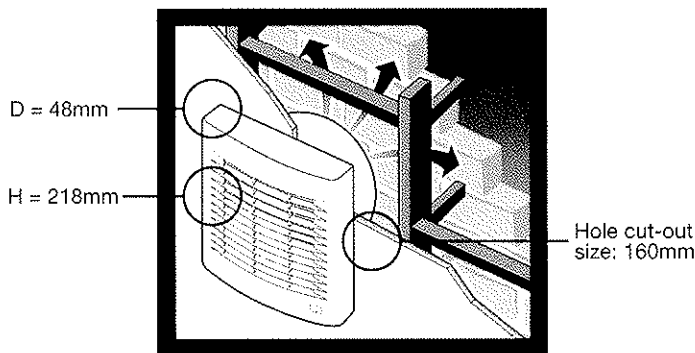

Fig 1. Fan ducted into wall cavity. (Kits for ducting through the wall or window are available from your usual wholesale outlet.)

INSTALLATION INSTRUCTIONS

- All fans must be fitted in accordance with AS3000-2000 (known as SAA wiring rules). This unit should be installed by a licensed electrical contractor or similarly qualified person.
- Switch off mains supply before making electrical connection.
- These fans are double insulated and do not require an earth connection.
- Choose a suitable mounting position. Check the other side of the wall and the cavity for obstructions such as studs, pipes, wires etc. If necessary, adjust the mounting position to clear these. These exhaust fans should be mounted as high as possible and must not be installed within the splash areas of showers, baths or tubs, or within 120cm of a stove.
- If ducting through the wall to the outside or if fixing to a window refer to the instructions in the 'wall ducted' kit or to the 'window mounting' kit (available separately). For extraction into wall cavity the following instructions apply;
- In some homes, the fan will fit an existing ventilation hole after removal of the vent cover.
- Make a circular 160mm hole in the inside wall.
- Fix the cable to the cable retention grip, allowing enough cable to connect to the terminals. Make electrical connections. (See electrical wiring diagram over.)
- Connect the cable to the terminal block.
Note, these units are double insulated, and do not require earth. (See electrical wiring diagram over.)
- Connect the cable from the fan to the switch.
- Fix the fan firmly to the wall with four screws.
- Replace the fan cover and tighten the base screw.
- Switch on and test.
- The appliance is not intended for use by young children or infirm persons without supervision.
- Young children should be supervised to ensure that they do not play with the appliance.
- Fans used for tropical climates.

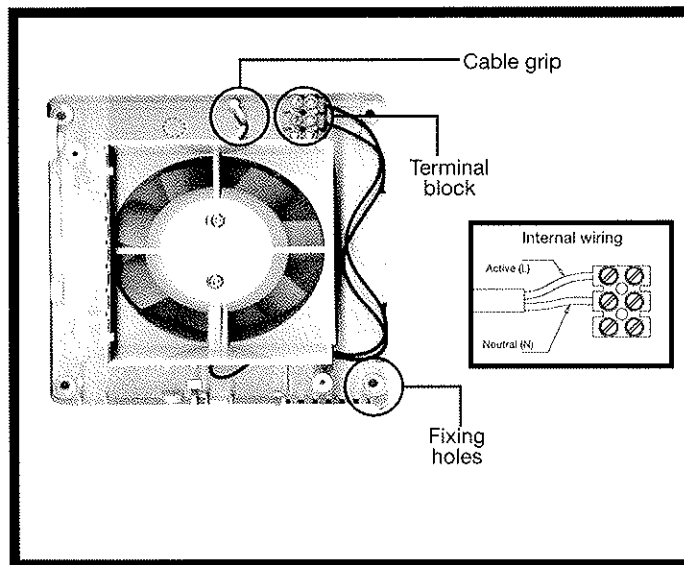
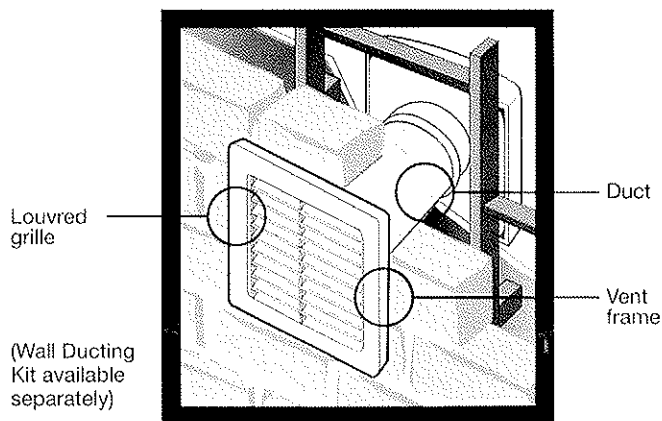

Fig 2. Cat R621/8A and R621/9A without time delay

Instructions for installing HPM R621/7A, R621/8A, and R621/9A through a cavity wall using HPM Cat R621/6D Wall Ducting Kit.



A suitable position must be found that will suit

1. the location of the fan in the room,
2. the position of the vent on the outside wall and
3. the location of studs, pipes, wires inside the cavity.

Make a circular hole 160mm in the outside wall in line with the inner hole.

From the inside. From the inside, secure the ducting to the fan by using the cable tie supplied. It is vital that the strap is pulled tightly to avoid the possibility of the ducting coming away from the fan when pulled from the other side.

Use screws to fix the fan to the inside wall. The screws and the method of fixing will depend on the inside wall material. (Also see installation instructions on the front page.)

From the outside. From the outside, pull the ducting through the outside hole. The stretched length of the ducting material is approx. 350mm which should be well in excess of requirements. Pull duct tightly and cut the excess ducting off, leaving approximately 50mm to spare. Remove the inner louvred grille section by gently prying open with a screwdriver.

Attach the outside vent to the remaining duct with the other cable tie so that there is as little slack ducting as possible. Tighten the cable tie strongly. Push the vent frame back into the hole and attach with the appropriate screws for the wall material. Snap in the louvred grille from the outside with the louvres pointing downwards.

Note: It is desirable to have the ducting as taut as possible as any slackness may restrict the air-flow through the ducting.

Instructions for installing HPM Cat R621/7A, R621/8A and R621/9A exhaust fans into windows using HPM Cat R621/6WA Window Mounting Kit.

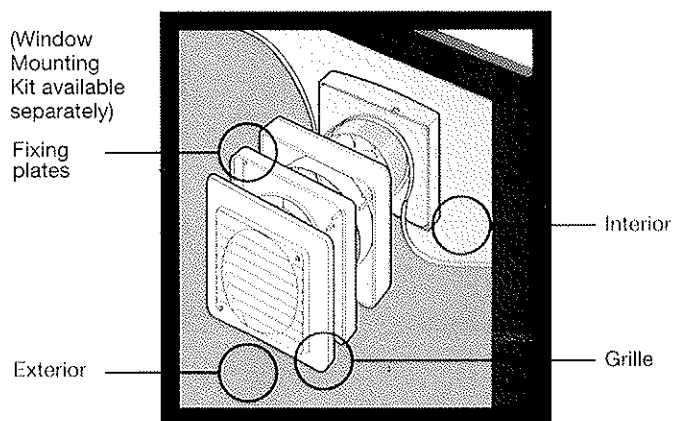

Cut a 160mm diameter hole in the glass using a circular glass cutter. (HPM recommend a qualified glazier performs this task.) The hole should be positioned as high as possible for greater effectiveness but no closer than 200mm to the edge of the glass.

Place the fan spigot through the hole in the glass from the inside with a gasket to each side of the glass.

From the outside, place the spacers as required, with the locating pins facing outwards. For double-glazing and glass up to 40mm thick, one of the spacers may be discarded.

Draw the assembly together with the threaded fixing ring. Do not over-tighten.

Fix the exterior grille in position using the screws provided. The louvres must point downwards.

After installation ensure that impeller rotates freely.

Warranty

HPM Cat R621/7A, R621/8A and R621/9A are warranted as here and after appears, against faulty material and/or workmanship for a period of one year from date of purchase. The obligation of the manufacturer, under this warranty, is limited to servicing and replacing defective parts when the unit is returned to HPM Industries, or the distributors in your state, freight pre-paid. This warranty

becomes void on any unit which has been tampered with or damaged by accident, short circuited, loaded beyond rating or damaged otherwise by improper operation. The warranty is also conditional on the unit being installed by a licensed electrical contractor. All other warranties, whether expressed or implied, and whether arising by operation of law or otherwise are hereby excluded.

HPM Industries Pty Ltd